

101 WORKSHOP TIPS



THE FAMILY
Handyman

The Family Handyman is a registered trademark of The Reader's Digest Association, Inc.
Copyright 2012 Home Service Publications, Inc.

Built-in tape dispenser

Tape's easy to nab from your pegboard if you install a recessed-style toilet paper holder. Just cut a hole in a convenient spot on the pegboard, mount the holder and store your tape on the spring-loaded bar.

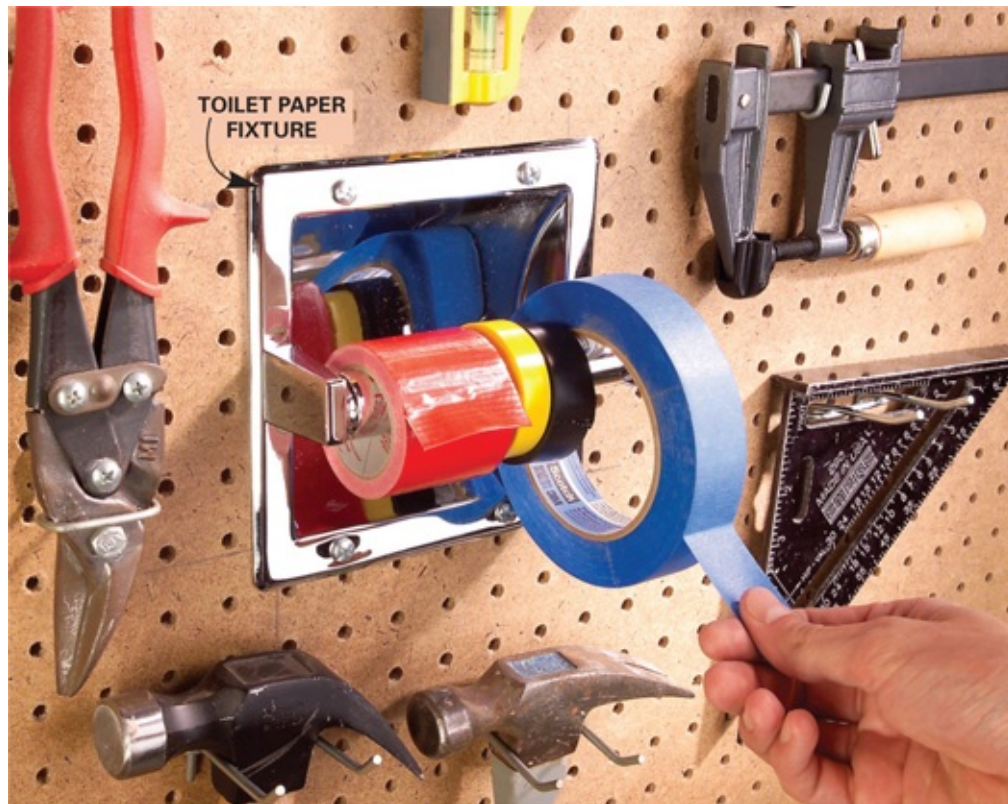

Pie plate storage pockets

Screw cut-in-half pie tins and heavy-duty paper plates to a shop wall and you've got space-saving storage for the sanding discs, circular saw blades and abrasive discs that like to hide in a drawer. Be sure to tape the sharp edges on the cut pie plates to protect your fingers!



Stretchy pipe clamps

Moaning again that your pipe clamps aren't long enough to assemble your new “monster-piece”? Pipe down and quit whining! A few extra 2- and 4-ft. pipe segments plus a handful of pipe couplings are all you need for the extra-long or extra-wide job. Screw couplings and extra pipes to those too-short pipes to create the needed lengths. If the clamps are under the wood, add spacers slightly higher than the couplings perpendicular to the pipes. When you're finished, unscrew and store the extra pipes with couplings and you'll be ready for the next jumbo project that comes down the pipeline.



Hardware lassos

To keep your hardware neat and accessible, thread nuts, washers, sockets and other items on short pieces of 12- or 14-gauge electrical wire, then hang them on a toolbox handle or a pegboard hook. Twist the ends of the wire into hook shapes that interlock for easy closing and opening.



Studly clamp storage

Clamps scattered and hard to find when you need them most? Here's a way to keep them in one spot. Hang bar clamps on horizontal scraps of 2x4 screwed between open-wall studs. Add another board or two for glue bottles, dowels and biscuits. To hold C-clamps and spring clamps, drill holes in the studs and install lengths of 3/16-in. threaded rod, tensioned with 1/4-in. fender washers and nuts.

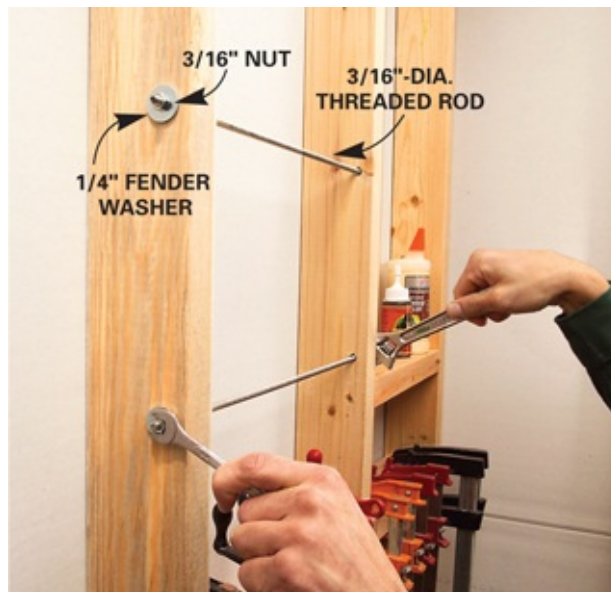

'Tween studs shelving

Store smaller containers—spray paint, putty cans, glue bottles—right in the wall! Screw shelf brackets to the studs, then install shelves, cut from standard 1x4 boards, on adjustable clips. The boards fit perfectly; there's no need to saw them to width.





Muffin tin hardware bins

Work surface cluttered with miscellaneous nails, screws, hardware, whatever? Clean it up and still keep that stuff at your fingertips.

Attach a muffin tin under a shelf with a single 1/4-in. x 1-1/2-in. flat head machine screw. The tin pivots out from beneath work surfaces to organize and serve up any little doodad you frequently use. And you store all that little stuff without using up a single square inch of workspace. For best results when installing your muffin bins:

- Use muffin tins made from heavier gauge metal.
- Drill and countersink a 1/4-in. hole in the shelf top, so the top of the screw is flush with the shelf.
- Place 1/4-in. fender washers above and below the rim of the muffin tin.
- Tighten two nuts against each other on the underside so the threads won't loosen.





Blades on board

Use tape or twist ties to attach spare blades to the frames of your hacksaw and coping saw. The next time a blade breaks or dulls, you won't scratch your head trying to remember where you put the spares.



Floor lamp for the shop

This lightweight, height-adjustable pole lamp will instantly illuminate every tool or project in your shop. You'll need:

- A 68-in. piece of 1-1/4-in.-diameter wood closet rod (\$8 at a home center)
- Two 16-in.-long pieces of 2x4
- Two 4-in.-long pieces of 2x4
- A clamp light

Overlap the two long 2x4s to make an X-shaped base, securing it with 3-in.-long screws. Then screw the 4-in. pieces under the upper piece to level the base. With a spade or Forstner bit, drill a hole in the center of the base for the closet rod. Check the diameter of the rod before drilling. If the diameter is between 1-1/8 and 1-1/4 in., use a 1-1/8-in. drill bit and file and sand the hole for a snug fit.



Oil-bottle hardware tote

Here's a fun little project to keep your screws, nails, nuts and electrical whatsits handy and neatly organized. To make one, you'll need:

- Six quart-size motor oil bottles (empty!)
- One 9-in. x 7-3/4-in. floor made from 3/8-in. or 1/2-in. plywood
- One 7-3/4-in. x 6-in. plywood handle
- Two 3-1/2-in. x 9-in. plywood sides

With a utility knife or snips, fashion the oil bottles into bins with 15-degree angled sides starting 2-1/2 in. up from one side. (The 12-oz. hash mark on the bottle is great for the low end of the angle if yours has them.)

Saw a handle slot in the vertical piece, and saw 15-degree angles on the sidepieces. Glue and nail the six-pack together. Add solid wood strips along the open sides to keep the bins from falling out and to make it easy to pull one out as needed.



Easy-to-access cordless tool chargers

Mount charger stands for your cordless tools on scrap pieces of pegboard and hang them on a pegboard wall so they don't become an octopuslike tangle on a shelf or workbench. Just pull one out for charging, or plug it into a power strip under the pegboard and charge batteries right on the pegboard. Most chargers have mounting holes or keyhole slots on the bottom. For those that don't, use a large hose clamp to mount them.



Carpet pad for soft footing

A double layer of foam carpet pad makes a luxurious but inexpensive anti-fatigue mat beside workbenches and power tools. Cut the pad to size with a utility knife, scissors or tin snips. To avoid tripping and to keep the edges from curling, tape down the perimeter with packing or duct tape.



Pointy-tool pincushion

Store router bits, drill bits, screwdrivers, awls, pencils, Allen wrenches and hole saws in a hunk of 1-1/2-in.-thick rigid foam insulation.

To make this pointy-tool pincushion, just glue the foam to 1/2-in. plywood sized an inch wider than the foam. Be sure to use foam-compatible adhesive (PL 500 is one). Then press the foam into place and let it dry for a few hours. Punch holes for the accessories by rotating a small-diameter Phillips screwdriver or an awl at a slight angle into the foam. The tools will widen the holes to fit as you push them in. Screw the plywood to a shop wall over your workbench and load it up!



Rosin paper workbench cover

Here's instant protection for any kind of messy job. Before you start, just unroll enough rosin paper from this jumbo paper towel holder to protect your workbench. The thick paper absorbs all the glue or finish. When the paper gets too dirty, tear it off and throw it away. A roll of rosin paper is 170 ft. long, so one will last a long time. Here's how to build your paper holder:

Buy a roll of rosin paper and a length of 1-1/2-in. pipe (\$12 for a 4-ft. length) at a home center. Round up some scrap lumber and get ready to do a little bit of head scratching to customize a bracket arrangement that works with your bench design. Our setup should give you the general idea. Bore 1-7/8-in. holes in the scrap wood brackets. Screw keeper strips over the holes to keep the pipe from falling out as you unroll the paper. Use a handsaw to cut the paper roll and a hacksaw to cut the pipe to match the width of your bench. Then load the roll and start dripping stuff all over it.





Table saw extension table

Make this knockdown table to support larger workpieces on your table saw. You'll need:

- one 3/4-in. plywood tabletop sized to fit your saw
- four 1x2 border boards to reinforce the plywood top
- two 1-1/4-in.-dia. iron pipe legs threaded on one end
- two 1-1/4 in. pipe flanges
- two 5-in. square x 3/4-in. blocks to attach the flanges to the table
- three 5/16-in. x 3-in. hanger bolts and Wing-Nuts
- one 3/4-in. x 3-in. hanger bolt support board
- wood screws

Build the plywood tabletop (border included) to equal the table saw's front-to-back dimension. Make it wide enough to create at least 48 in. of overall support on the left side of the blade. Screw on the 5-in. square blocks and pipe flanges, then measure for the leg sizes while holding the table level with the saw. Have a home center thread and cut the pipes to length. Predrill the holes into the edge and support board to match the holes in the left edge of the saw table. Turn the hanger bolts into the support board with 2 locking pliers, then mount it to your saw by tightening the Wing-Nuts. Adjust the legs to level the table with the table saw and go to work!



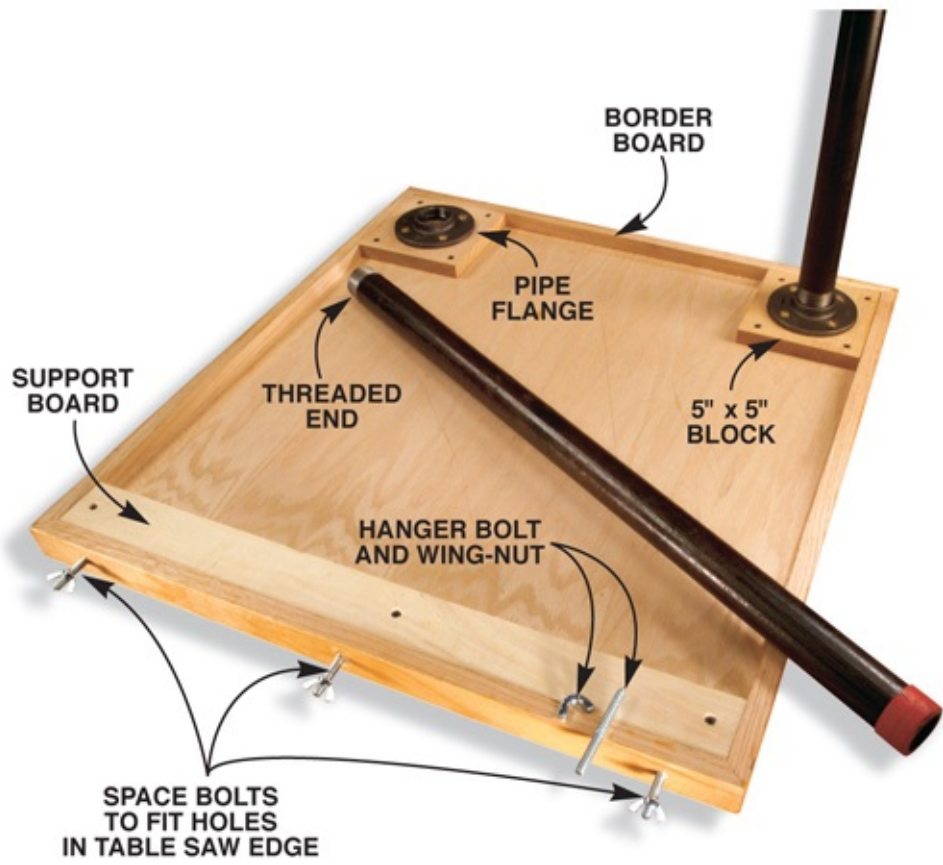

PVC socket shelves

Here's a great way to use leftover pieces of PVC pipe. Cut them into various shorter lengths and glue them to a 4-in. wide board with construction adhesive. Attach the boards to a shop wall with angle brackets bent downward 15 degrees or so. Then fill the pipe pieces with screws, nails, glue, spray paint and, sure, a hot cup of coffee.

With the shelves angling a little downward, it's easier to see and grab the contents. Two-inch pieces of 3-in. dia. pipe are great for screws and nails, and 5-in. long pieces of 1-1/2 in. dia. pipe are neat holsters for pencils, files, paint brushes and Popsicle sticks.



M&M bit tubes

Buy some mini M&Ms in small and megasized tubes, evict the candy bits (mmm good) and load up the tool bits. The shorter tubes are ideal for all styles and lengths of driver bits, and the megasized tubes fit commonly used drill bit sizes.



Taped-up caulk tubes

Here's a slick tip to keep partially used caulk tubes well sealed and at hand. Fold a piece of duct tape over the open tube to seal it, leaving a few inches of extra tape. Drive a nail through the tape and hang the tube on pegboard.



A wrench rack from the clothes closet

Screw a tie/belt rack (available at discount stores) to a bare spot on the wall over your workbench and hang the wrenches—SAE and metric—where you can swiftly nab and put them away in orderly fashion.



Easy-pick toothpick

Pick-ture this. You're assembling a delicate project. You dip a toothpick in glue and apply the glue with the precision of a surgeon. Way to go! Now you can dispense your toothpicks with equal accuracy. Drill a 1/4-in. hole in the box or plastic holder, give the box a little shake, and pull one out. No more opening and closing that flimsy paper box or removing the lid from a plastic container and losing the darn thing.

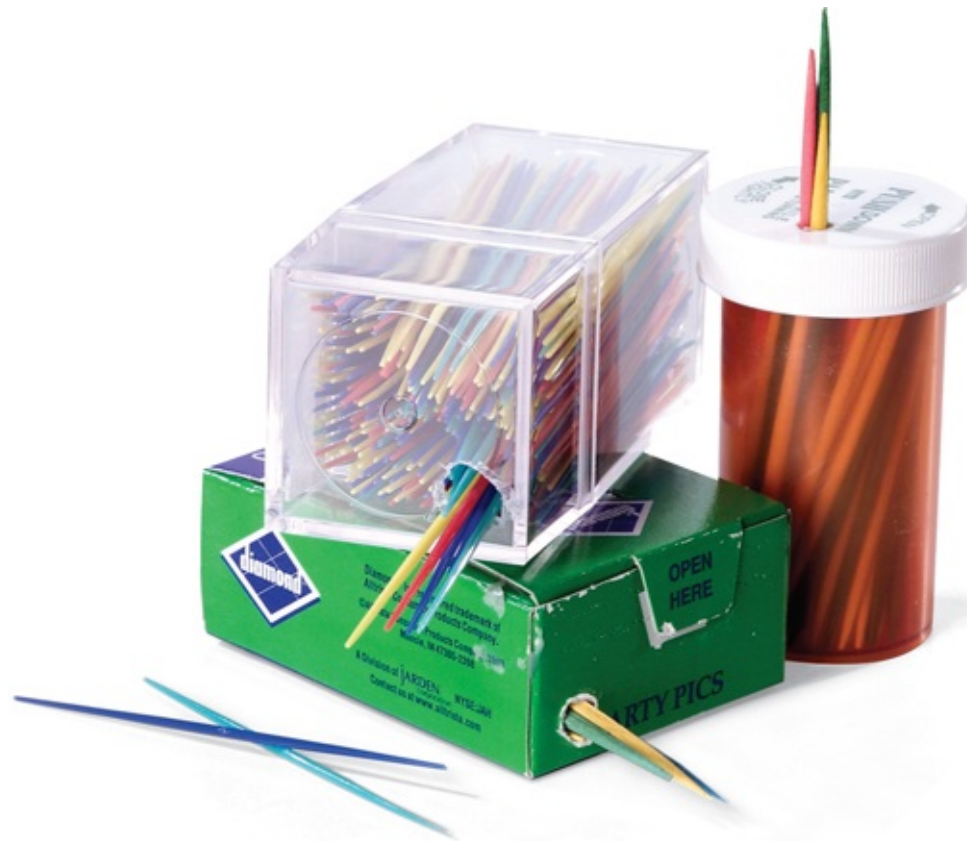

Bits on board

If your cordless drill comes in a plastic case, you've sung the no-room-for-bits blues. Don't sing 'em anymore. Simply bolt drill and driver bit cases to the outside of the case with 1/2-in. long bolts, nuts and washers. Now they'll tag along for easy, snap-open access to any drill, driver tip or socket you need.



Pegboard shelves

Here's a slick way to store a whole cluster of tools on pegboard with only two pegs. Cut some 2-1/2 in. wide mini shelves; drill holes or slots for router bits, screwdrivers, chisels and files; then drill a couple of 1/8-in. holes in the edges for the 1/8-in. diameter pegs. With a vise and pliers, bend the pegs to about 85 degrees and hammer them into the holes. Be sure the pegs fit tightly in the wood so the shelves can't fall off. Thanks to reader Bob Chant for this handy tip.

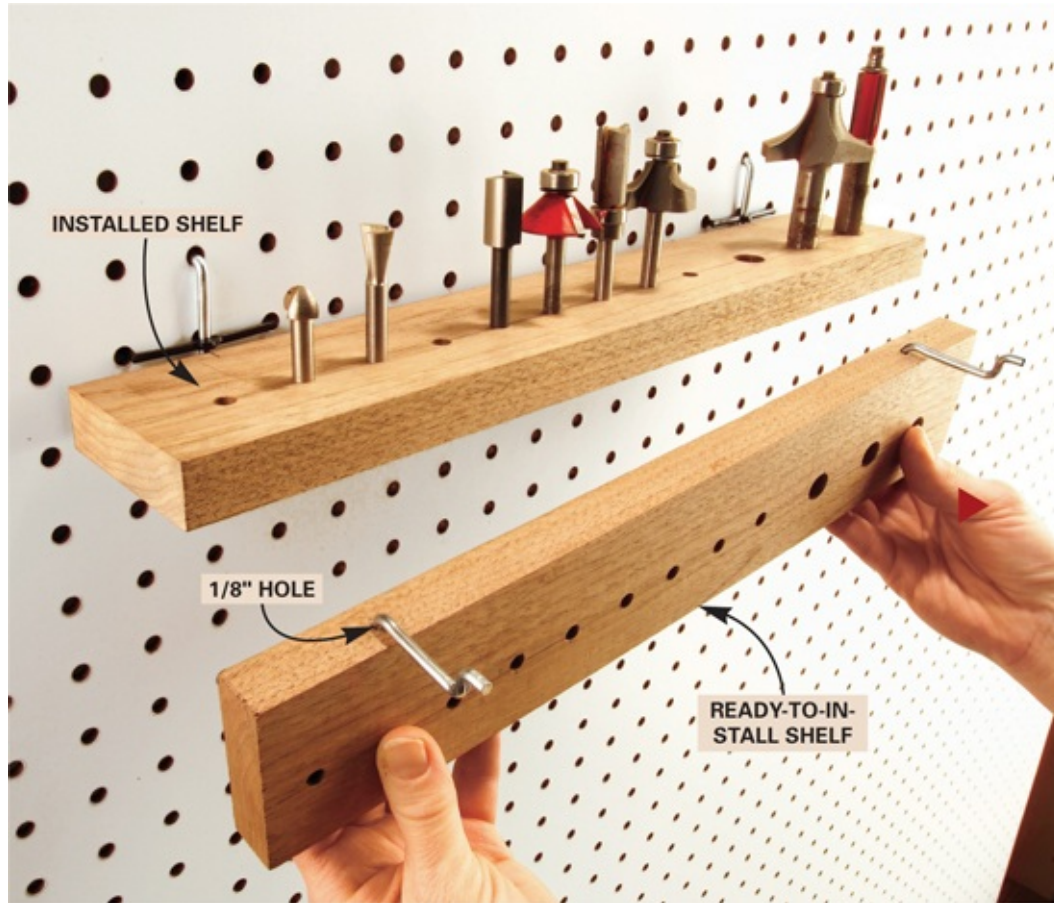

Painting gear hangout

Organize your paint brushes, scrapers, roller frames, rags and paint cans with this shelf made from two 1x8 boards screwed together and reinforced with metal shelf brackets. The one shown is 38 in. long to fit three brackets of sliding spring grips that we mounted under the shelf for tool storage. Build and attach this shelf to a shop or basement wall.





Canned safety equipment

Keep safety equipment easy to find and mostly dust free. Screw a 2-lb. coffee can to a convenient spot on your shop wall and load it with dust masks, safety glasses and earplugs. Snap on the plastic lid and you'll know right where to go before turning on the saw or sander.

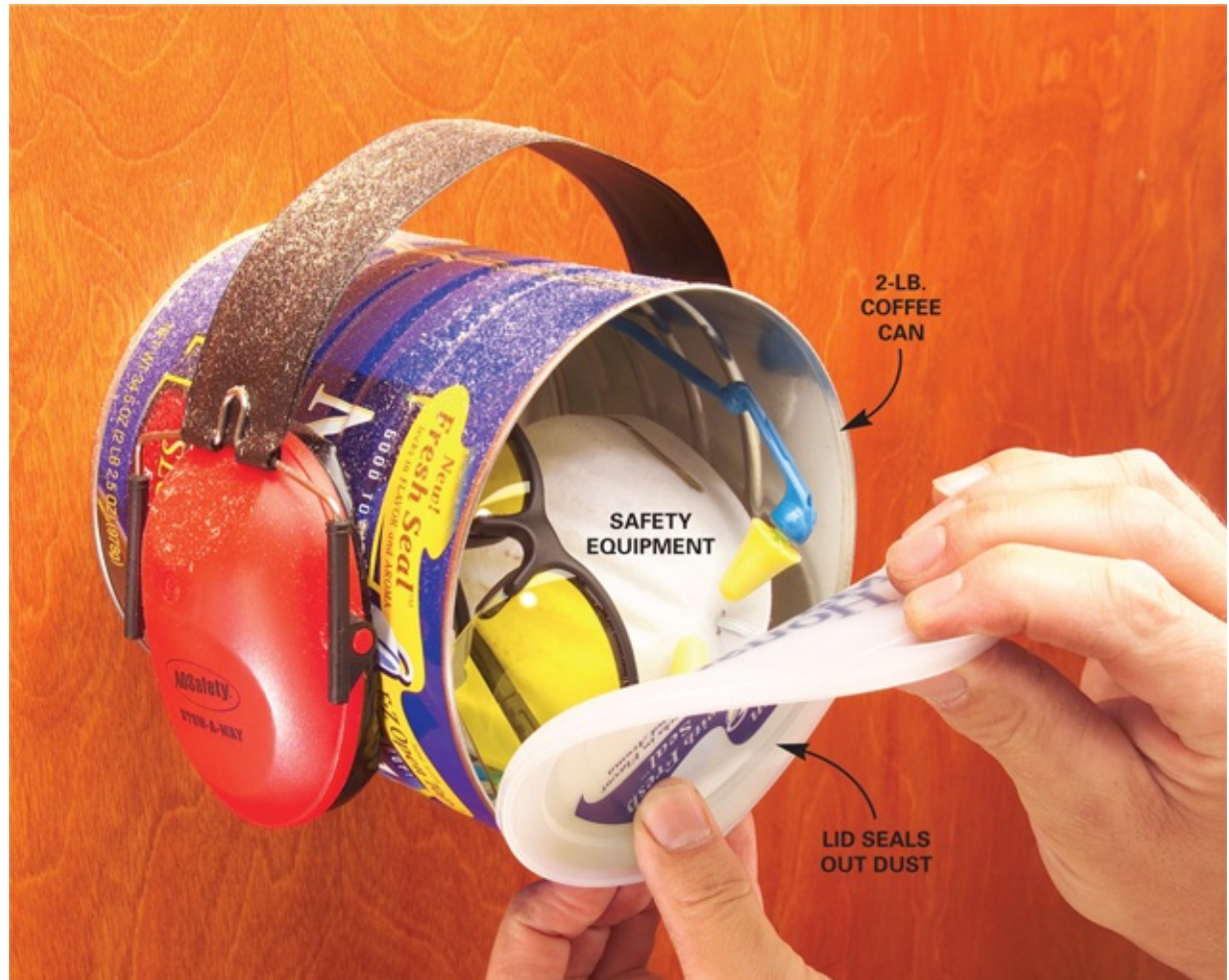

On-a-roll pegboarded doors

Maximize hand tool storage in a tool cabinet with this slick tip. The key to this project is a 4-ft. long By-Pass Sliding Door Hardware Set. You mount 1/4-in. pegboard onto it, making sure to provide enough room (2 in.) to hang tools on the pegboard and still allow it to slide by the door in front. The trick is to insert 1/2-in. plywood spacers in the roller hardware as shown. You can use the floor bracket that comes with the slider hardware to maintain the same 2-in. clearance at the bottom of the cabinet. For door handles, simply drill a couple of 1-1/4 in. holes in the pegboard with a spade bit. Now pop in the pegs and hang up your tools.



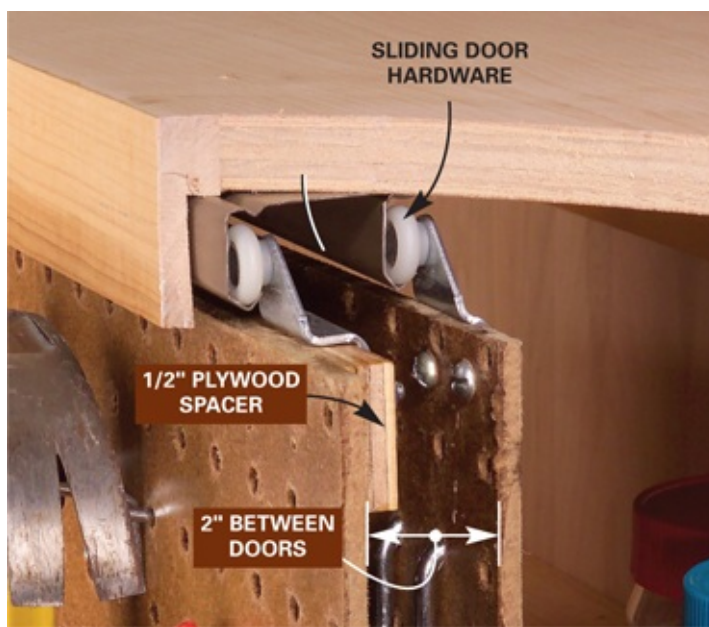

Pipe clamp pincushion

The pipe clamps are calling, the pipe clamps are calling—for storage, that is. So furniture maker David Munkittrick responded with this slick idea. Cut two 12 x 16-in. pieces of 3/4-in. plywood and temporarily screw or nail them face to face. Drill 1-1/4 in. holes (if your pipes are 1 in. outside diameter), spaced 3 in. apart, through both pieces. Pry the plywood apart, then screw them to two 16-in. long pieces of 2x8 to make an open-ended box. Add a couple of narrow 3/4-in. boards on the bottom for feet, then set the box in a convenient spot along a shop wall. To keep it from sliding, attach it to the studs with screws driven through the 2x8s.

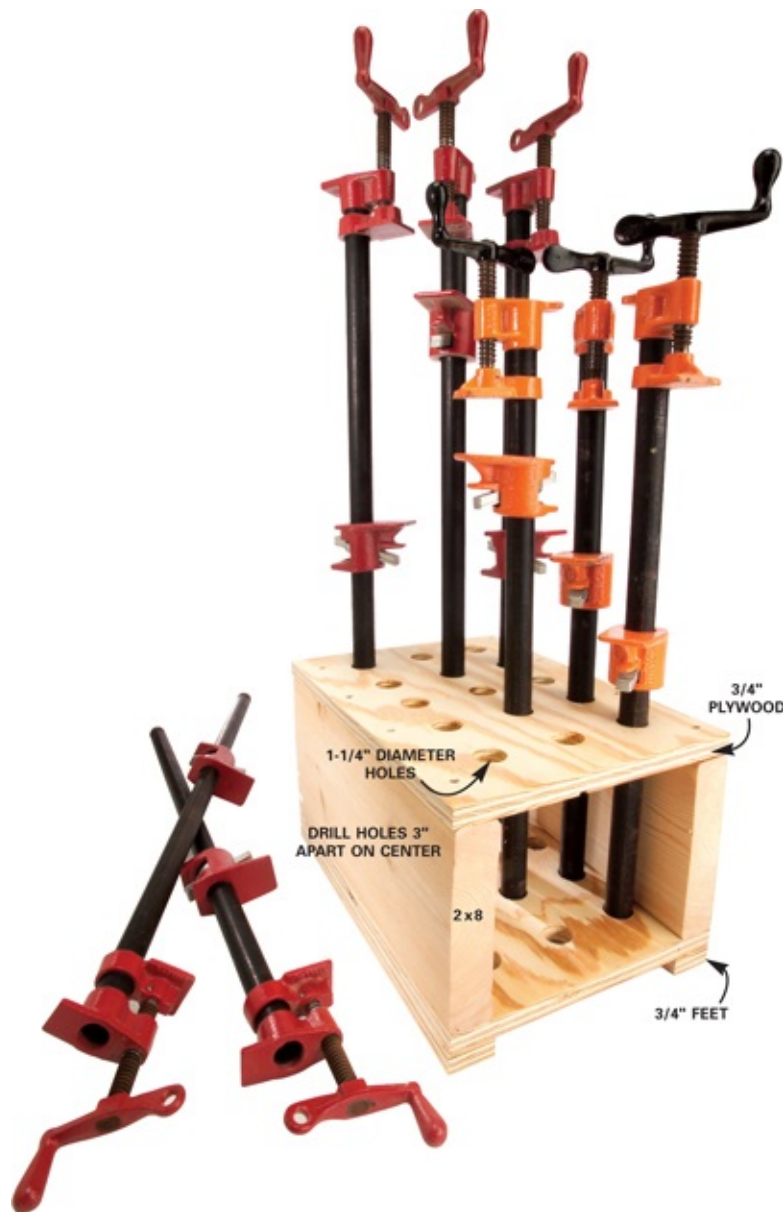

Chisel pockets

Here's a neat tabletop chisel storage idea that's a snap to build from scrap boards. It angles the handles toward you for easy reach.

Start with a 4-in. wide board. Using your table saw, cut stopped slots to match the width and depth of each chisel (plus some wiggle room). Screw or glue on another board to create the pockets, then run the lower edge of the doubled board through a table saw with the blade set at 15 degrees. Now cut three triangular legs with 75-degree bottom corners and glue them to the pocket board.

If you like, drill a few holes through the boards for pegboard hooks so the holder is easy to store on the wall.



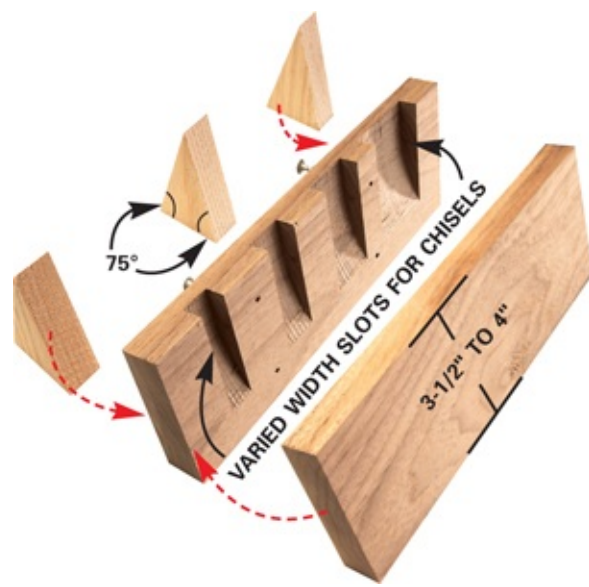

Quick-draw table saw accessories

Keep your table saw's miter gauge and push stick within ultra-easy reach with a couple of sections of 1-1/2 in. PVC pipe bolted or zip-tied to a convenient spot on the frame under the table. Attach the miter gauge holster using the existing frame bolts, or drill holes in the legs for machine screws. For the push stick holster, we drilled a couple of sets of matching holes about an inch apart on the pipe and tautly zip-tied it to the leg.

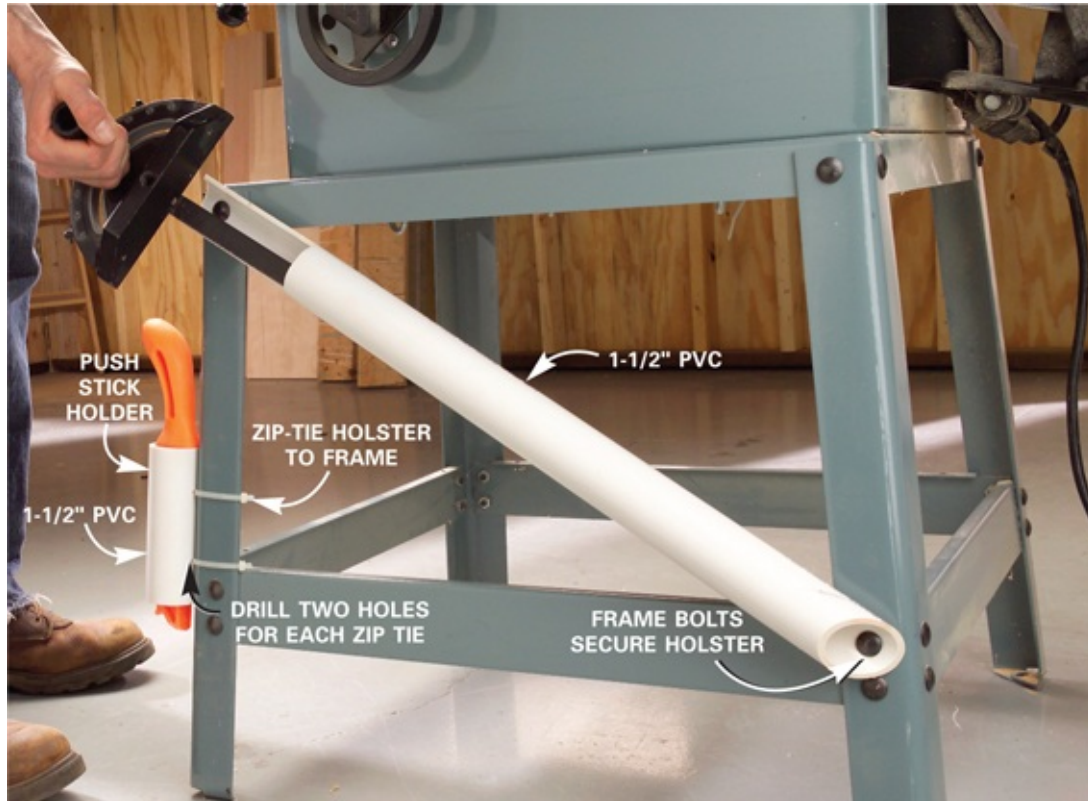

Pipe-clamp bench vise

Increase your workshop's vise-utility with a 1/2-in. pipe clamp screwed to one end of your workbench. It works like a third hand for all kinds of jobs and only takes a half hour to install.

- Start with a piece of 1/2-in. black pipe threaded on one end. Hold the pipe against your bench and mark the 1/4-in. diameter hole locations for the lag screws.
- Drill 1/4-in. diameter clearance holes through the center of the two 3/4-in. thick spacer blocks. The spacer blocks allow the clamp hardware to slide freely.
- Hold the assembled pipe clamp against the edge of the bench again and transfer the hole locations to the bench. Drill 3/16-in. diameter pilot holes 1 in. deep at these locations.
- Attach the pipe clamp to the bench using 1/4 x 2-1/2 in. lag screws (outfitted with washers) against the pipe. Tighten the lag screws with a wrench.

That's it! Now have fun discovering how handy this vise can be when you're building your next project.

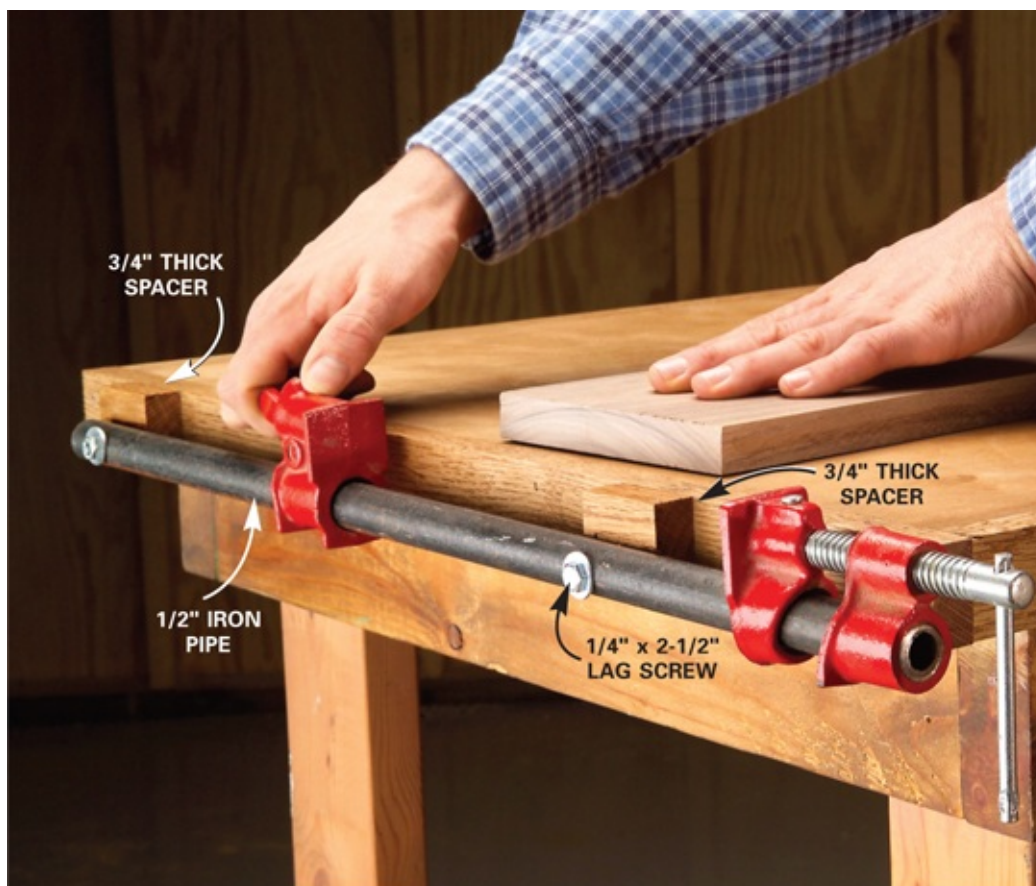



POSITION CLAMP SO 3/4" BOARD STAYS ABOVE CLAMP JAW

Fluorescent bulb storage

Safely store extra fluorescent bulbs in jumbo-sized vinyl-clad storage hooks in a handy location near your fixture in the shop, garage or basement. Cut the hooks off one end of a couple of mini Bungee cords and use zip ties to attach the severed ends to the top of two vinyl-clad steel storage hooks. Store several fresh bulbs and mark your bad bulbs with a marker and store them until it's time to recycle.



Drill holster

Avoid the sickening crunch—and possible damage—that happens when your cordless drill falls off a crowded workbench. Screw a 3-in. plastic adapter to the side or back edge of your workbench, and holster that tippy drill. Three-inch drainage adapters hold cordless and corded drills, so buy as many adapters as you have drills to keep them topple-proof and easy to grab.



In-the-bucket air tools

A 2-1/2-gallon bucket is all you need to store air tools and hoses on a wall right by the air compressor. Screw a 3/4-in. plywood shelf inside the bucket to create two storage areas, then attach the bucket to the wall with a couple of lag bolts and washers. Load up the bucket with nailers, nails, tire pressure gauges and other accessories and coil the hose around it.

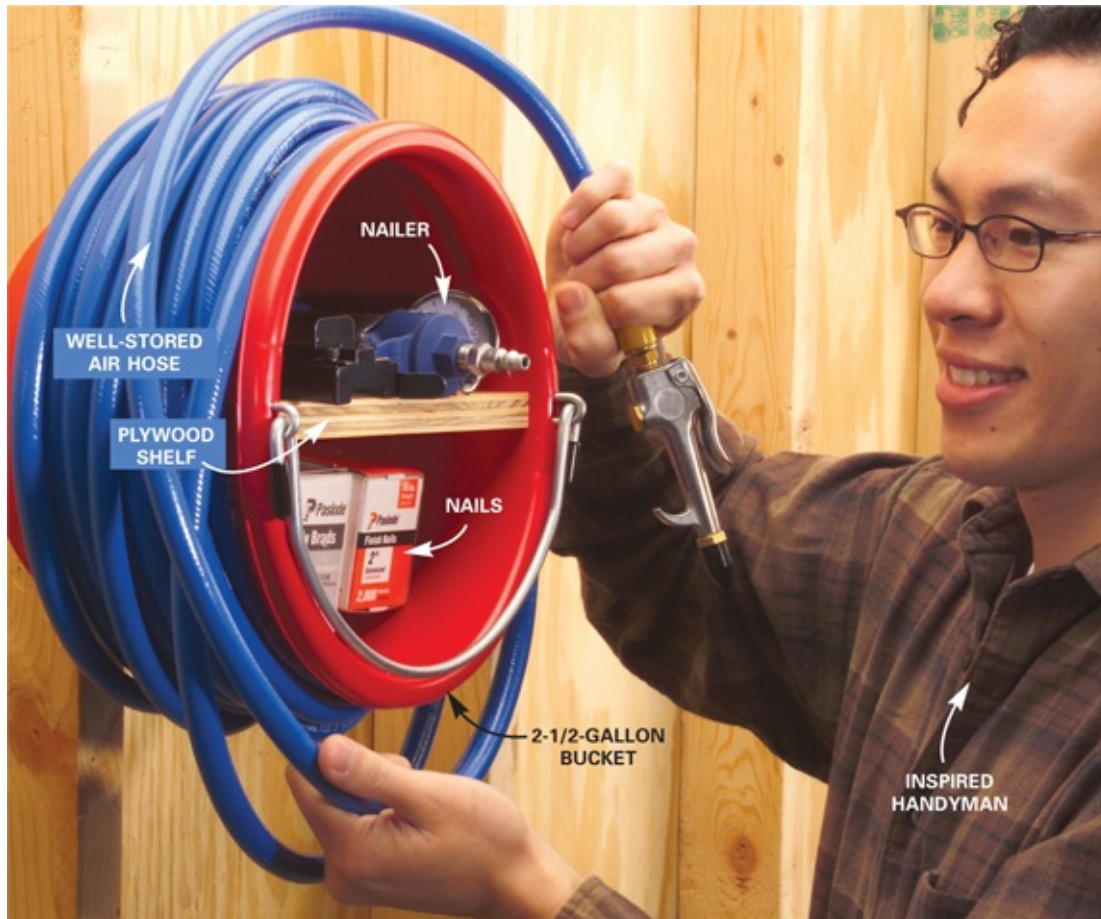

Ambient air cleaning on the cheap

Can't afford an air cleaner for those dusty woodworking jobs on the weekend? Sure you can! Attach a furnace filter with hook-and-loop tabs to the air intake side of a box fan and hang the fan between the ceiling joists so you won't bop your head on it while you work. Just switch it on and fine dust particles from sanding and sawing will be drawn into the filter by the vacuum created by the fan.



String-dispensing CD bins

Here's a great way to reuse empty CD bins. Drill a hole in the top of the bin for the string to slide through, then screw the lid under a shelf and snap on the string-loaded bin. Pull down and snip off the desired length and never worry that your ball of string will roll away across the floor dragging its tail behind it!



Cordless drill hangout

Here's a high and mighty way to prevent cordless drills from toppling off your workbench. Screw large vinyl-covered hooks to a convenient spot on a wall or exposed stud and hang up those drills for safekeeping and easy access.



Accurate angles for saws

For precise cuts, don't trust the sloppy angle gauge that's supplied with your table saw. Instead, use an 8-in. adjustable drafting triangle (at a drafting supplies store or online). Hairline gradations on the scale are easy to see for setting the angle you need. Then just hold the adjusted triangle against the blade or fence and your project parts will be cut precisely. P.S. As always, make the first cut on a scrap board to be doubly certain you've set your angle correctly.



Hijacked tackle box

When the fishing urge stops biting, put that old tackle box to use as a portable hardware and tool tote. Load the nifty fold-out compartments with screws, nails, bolts, tape, electrical connectors—what have you. Stash your pliers, screwdriver, wrenches, hammer, tape measure and other frequently used tools on the bottom level. When chores and repairs start nibbling at your conscience, you'll have the right tackle handy for the job.



Scrap bin on a roll

Here's a low-rolling wood scrap bin that'll capture all the cutoffs while you work on your next project. Bolt swivel casters to the base of a storage bin and it'll scoot right where you need it. Sure, you can take extra time to beef up the casters-to-bin connection by bolting plywood on before attaching the casters, but it's easier to bolt them right through the thicker, reinforced area of the bin's bottom.





BOLT CASTER
TO REINFORCED
(THICKER)
PLASTIC EDGE

Bandsaw blade hangers

If you've ever suffered the indignity—and possible danger to eyes and face—of a bandsaw blade uncoiling as you've pulled it off the peg you hung it on, you'll love this tip. Nest the coiled blades into binder clips and store them on your pegboard, and they'll never spring out at you again. Apply labels to the clip so you can simplify size selection and storage.



Magnificent magnets

Buy a handful of inexpensive, super-strong “rare-earth” magnets in varying diameters to store accessories on stationary power tools. You won't believe just how strong they are, but here's a clue: A 3/4-in. rare-earth magnet will lift a 22-lb. hunk of steel right off the floor. My drill press hosts magnets holding the chuck key and common sizes of drill bits. Magnets spaced on my table saw securely hold the miter gauge, blade-changing wrenches and a couple of saw blades to boot. For best results, lightly sand one side of the magnet with 100-grit sandpaper and glue it to the tool with a dab of cyanoacrylate glue (Super Glue).



Store sheet goods on a ladder

Got a decade's worth of leftover pieces of plywood, drywall and plastic laminate and spare boards? Here's how to round them up and protect them from moisture, dirt and dings. If you have an old extension ladder lying around, take the sections apart and lay one on the floor near a wall to use as a sheet goods rack. The rail will keep stuff from sliding off. It'll hold everything high and dry off the floor and ready to sort when that next project comes along.



Gluing pedestal

Ever scratched your head over how to position clamps on a project that requires clamping from all four sides? This gluing pedestal makes the job a breeze. Buy a 12-in. pipe nipple with pipe flanges on both ends and screw it to a couple of scraps of 3/4-in. plywood. Cut the pedestal top an inch or so bigger than the project to make clamping easier. Now, with the base of the pedestal clamped on your workbench, you can crank on the clamps from every angle—up, down and sideways. (Be sure to cover the top with plastic sheeting or wax paper, or the top will become a permanent part of the project.)

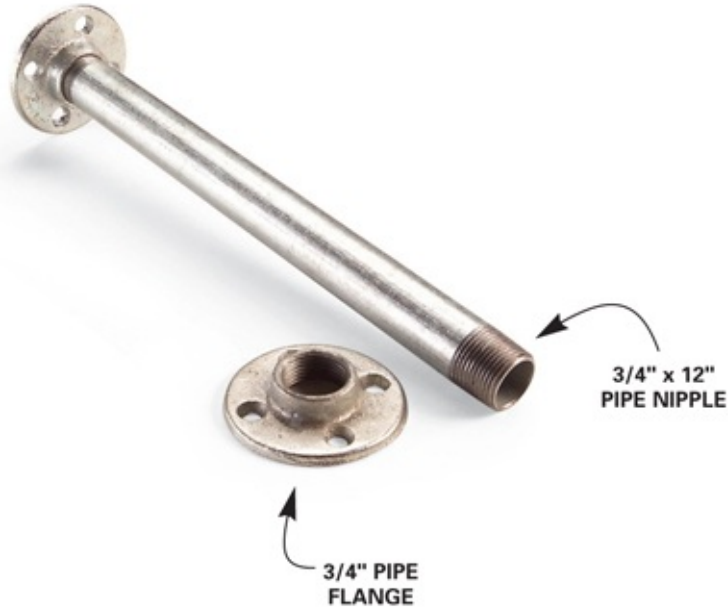



Glue-go-round

Here are four good reasons to build this glue caddy for your shop. First, no more hunting for the right type of glue; they'll all be right at your fingertips. Second, you can store the containers upside down. That keeps the glue near the spout—no more shaking down half-filled bottles. Third, upside-down storage helps polyurethane glues last longer without hardening because it keeps the air out. Last, the caddy is so *doggone* handsome.

Here's how to make yours:

First, arrange all your glue bottles in a circle with 1-in. spacing between the bottles. Add 2 in. to the circle diameter and cut out two 3/4-in. plywood discs. Drill 7/8-in. holes in the center of each one. Measure the various bottle diameters and drill storage holes around the top disc a smidgen larger than the bottles. Glue the discs on a 12-in.-long, 7/8-in. dowel, with a 5-in. space between the discs.

Add a knob of your choice, load up your glue, and you've got an instant grip on every type of sticky problem that comes your way.



“On the level” table saw

You've finally got your table saw on a mobile base so it's easy to pull out and put away on the weekend. Finish the job by finding a level spot on the floor that's also convenient for sawing boards without obstruction. Mark the wheel positions with bright-colored duct tape and now you can roll the saw to the same flat spot every time you saw.



Flux brush glue applicators

Keep a few plumber's flux brushes ready for spreading glue on your projects. You can get the brushes in the plumbing department at home centers. They're perfect for brushing on just the right thickness of glue. Bend the handles into U-shapes so you can hang the brushes on the edge of a jar half-filled with water to keep them from drying out. No cleaning needed. Just wipe off the excess water with a paper towel before use.



Easy-to-read wrenches

End eyestrain when you're hunting for the right wrench or socket. Wrap each one with a couple of layers of bright-colored tape, then write its dimensions on the tape with a permanent marker. (After a bit, you'll remember the colors and their corresponding sizes and won't even need the numbers.) Your eyes will thank you each time you change the oil, assemble that new wagon for the kids or work on the lawn mower.



Carpet cushion for project sanding

Don't scratch up the workpiece you just sanded by flipping it over on a dinged-up work-bench. Next time you sand a project, lay down a scrap piece of carpet to protect the wood, keep it stationary as you sand and dampen the sander vibrations on your hands. No scrap carpet around? A 2 x 6-ft. washable runner works great—just shake it out between jobs and roll it up for storage.



Overhead rag roost

Here's a hint that will take some of the frustration out of finishing. Make a little nest for the disposable paper rag box in the ceiling joists, just above the area where you do all your finishing. Anytime you need a rag, reach up and grab one. Perfect!



Laminate labels

Label cabinet drawers with pieces of plastic laminate and a permanent marker. Hotglue the labels so they're easy to pull off to relabel a drawer.



Wrench tote

Here's a gripping, portable organizer for all those wrenches and sockets. To make your own, cut a 5-in. handle slot in a piece of 14-in. x 11-1/2-in. x 3/4-in. plywood and screw it to the middle of a piece of 14-in. x 8-in. x 3/4-in. plywood. Band the bottom with strips of 1-1/4-in. x 1/2-in. plywood to reinforce the tote and keep the sockets and accessories on-board. For wrench storage, fasten 13-in.-long magnetic tool bars halfway up on both sides of the handle board. Tack or glue divider strips to the floor as needed for better socket sectoring. That's it—load and tote!





Table saw fence sheath

It's a lot easier to crosscut boards on a table saw or use the surface as a work-bench without the fence in the way. But where do you put it? How about tucking it away in a piece of PVC pipe bolted to the saw base? Buy and install a length of 4- or 5-in.-diameter PVC (measure your fence first!). Rip the leftover pipe in half and screw it to the top of the sheath. It's a great shelf for push sticks, wrenches, featherboards and other accessories.

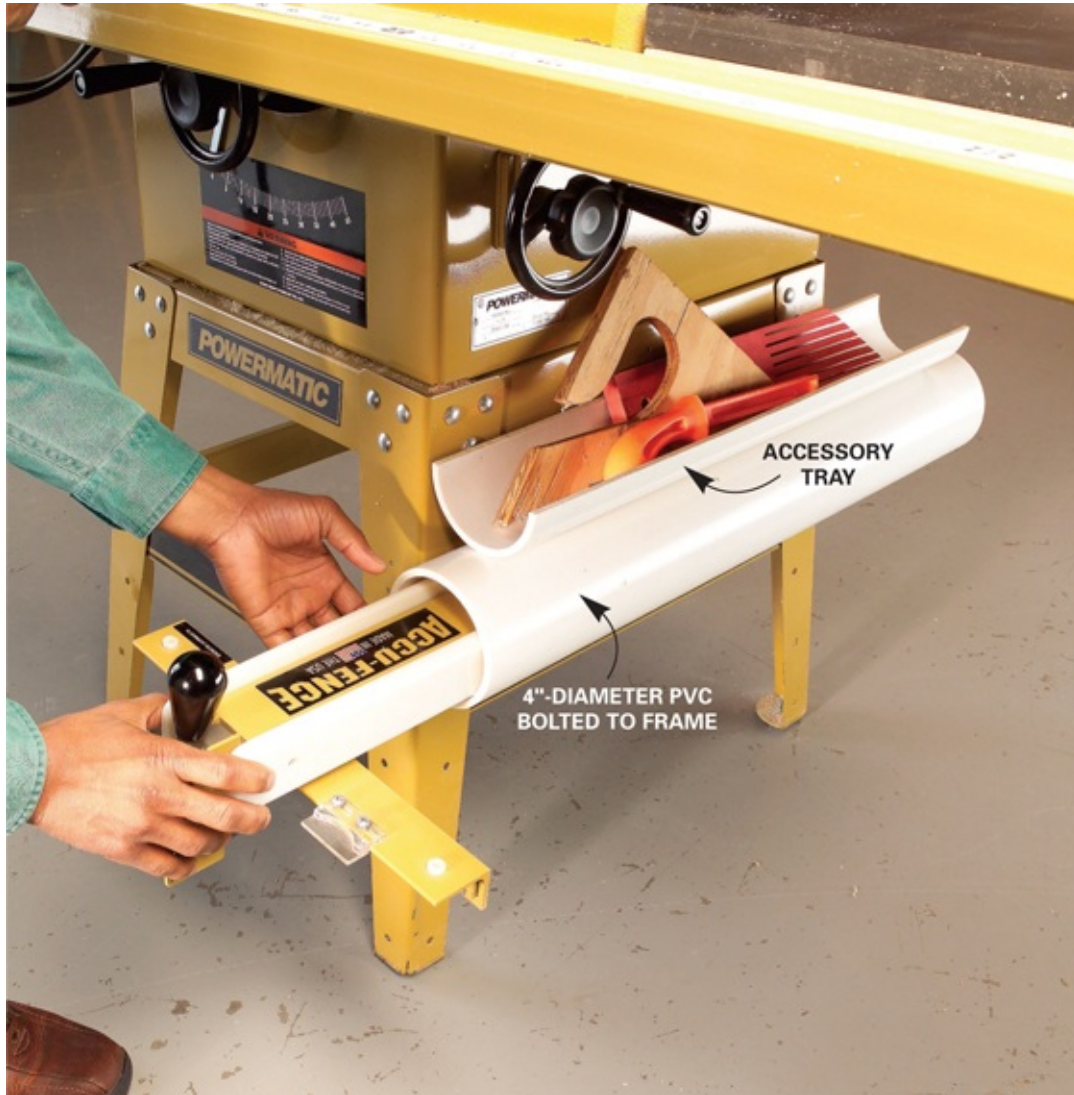

Dust-collectin', bit storin' router fence

This router fence is a masterpiece of convenience and efficiency. The router is mounted under an extension table attached to his table saw. When routing, slide the table saw fence over and clamps on a 5-in.-wide box with a mouse hole on the side for the bit recess. A drawer for bit storage pulls out of one end, and a shop vacuum hose press-fits in a hole in the other end to spirit away nearly all the chips.

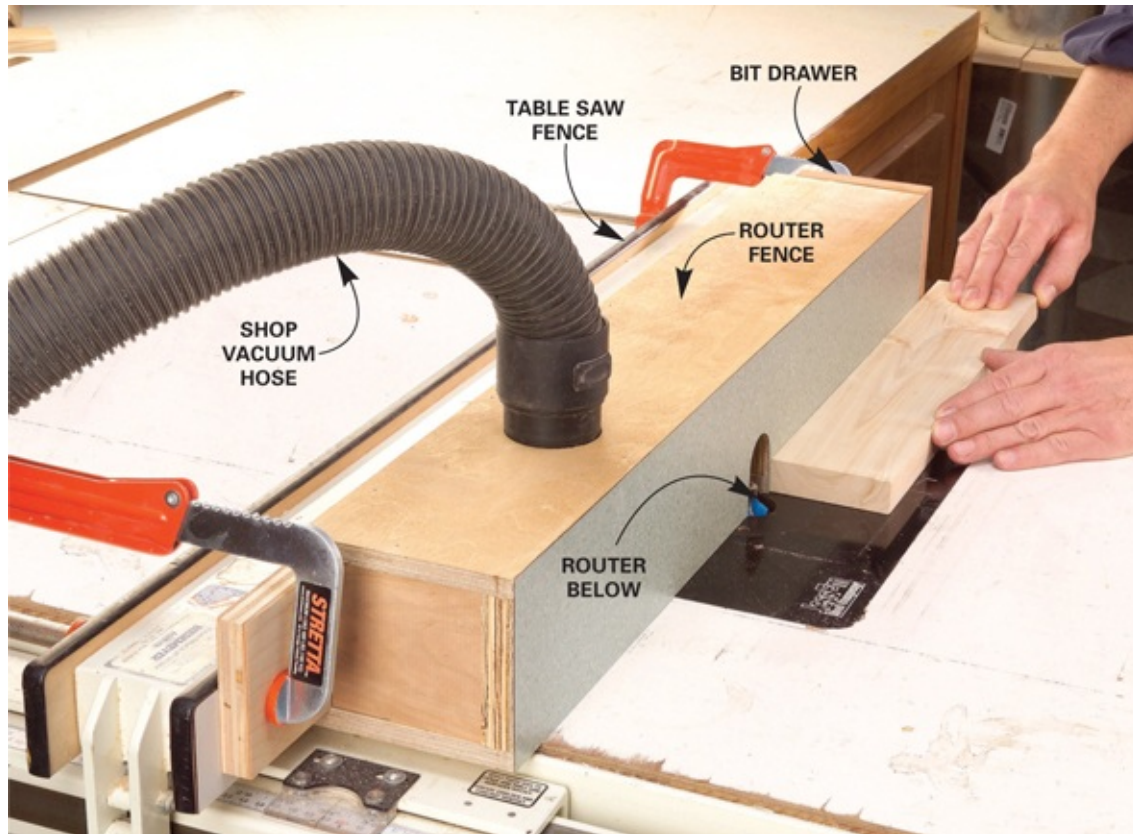

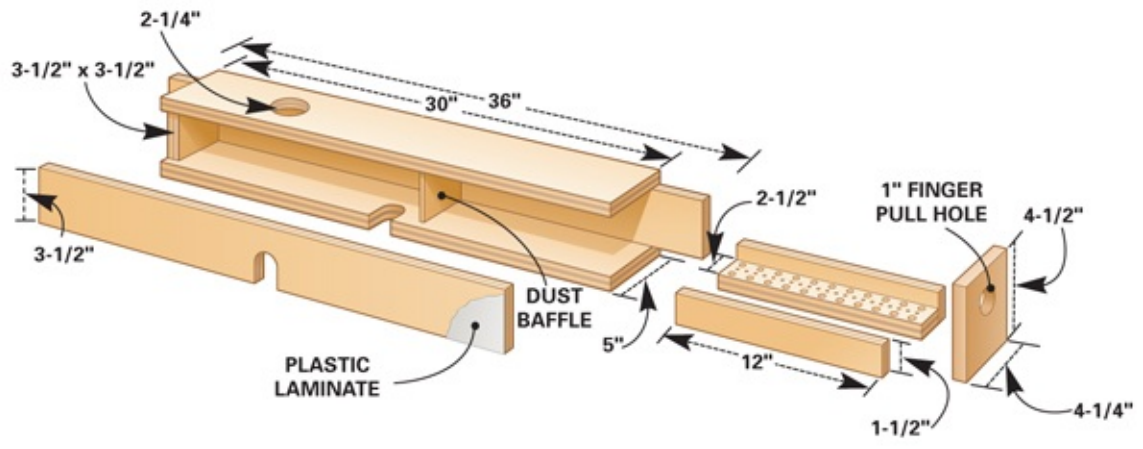

Miter saw waste

Got a huge pile of cutoff scraps on the table next to your miter saw? Add a drop hole right next to the saw to a recycling bin below.



Title your finishing cans

If you're like most DIYers, you have 10 years' worth of rectangular solvent and finish cans on your shelf, and it's hard to grab the mineral spirits can without first pulling out the acetone, the walnut stain and the denatured alcohol cans. Try this great solution. Set all the cans side by side and spray them with white appliance paint. When the paint's dry, write the names with a permanent marker or paint pen on the painted spines like a book title.





APPLIANCE PAINT

MASKING TAPE

Stay-flat plywood spacers

Plywood or other sheet stock can warp, especially if it's stored surface to surface. The blocks separate the sheets so air can circulate on both sides. Flat sheets from the lumberyard stay flat this way, no matter how long they're stored. The leather is flexible, so you can use them on any combination of thicknesses of sheet goods. The blocks are a snap to make from scrap wood and leather. Cut two 1-in.-wide strips of leather (or vinyl or heavy cloth) and space and screw 2-in. x 3/4-in. x 1-in. blocks along the strap. The air space also keeps them a lot easier to grab when you need to pull one out. For full sheets, use three sets of spacers, one at each end and one in the middle.



High-and-dry plywood

Walking through the garage connected to Bruce's shop, I noticed some riser blocks supporting a few sheets of plywood. "I just cut some 2-in.-wide plywood scraps and screwed them together to form T-blocks and store the plywood over them. If snow, slush or rain sneaks in on the car tires and gets the floor wet, the wood is safe."

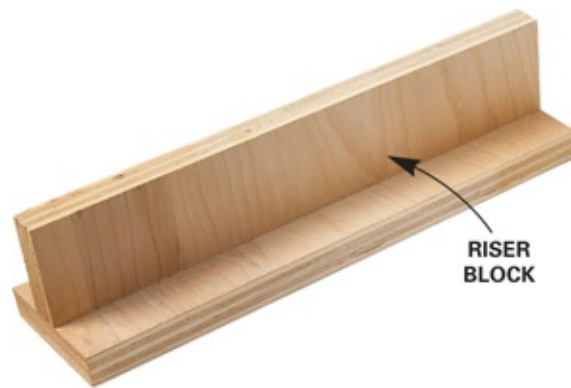

Legible sanding discs

Hook-and-loop sanding discs work great on sanding jobs, and you can reuse them several times before they're worn out. But it's almost impossible to read the grit labels on the discs after you've used them once because the markings get scrubbed off by the loops. So whenever you open a new pack of discs, write the grit label on the back with a permanent marker. Now you'll switch from grit to grit without straining your eyes.



Pencils on the double

Saw a package of pencils in half with a fine-tooth saw and stick pencil cap erasers on the eraserless halves. You've just doubled your stock of pencils and made them a lot harder to break!





Cordless drill-driver station

This useful hangout for cordless drill-drivers stores them near their chargers so you won't forget to charge them, and keeps them close at hand and ready to go. Best of all, with their own little eagle's nest, your drill-drivers will always be where you can find them.

To make one, rip 3/4-in. plywood into 8-1/2-in.-wide strips. Make your drill-driver station wide enough to hold all your drivers. Cut slots in the lower shelf to fit the driver handles, then glue and nail the station together. Screw the station to a wall near an electrical outlet.



Gauge blocks from scraps

Go through your collection of scrap plywood and cut a few little squares of each thickness. Every time you work with a new plywood thickness, cut a few squares of it, too. Label each square with its thickness and keep them handy. They're great for measuring depths of grooves and gauging saw blade and router bit cutting depths. Pile up various squares to get just about any thickness you want. For many small measuring tasks, it's easier to use gauge blocks than to use a tape measure.

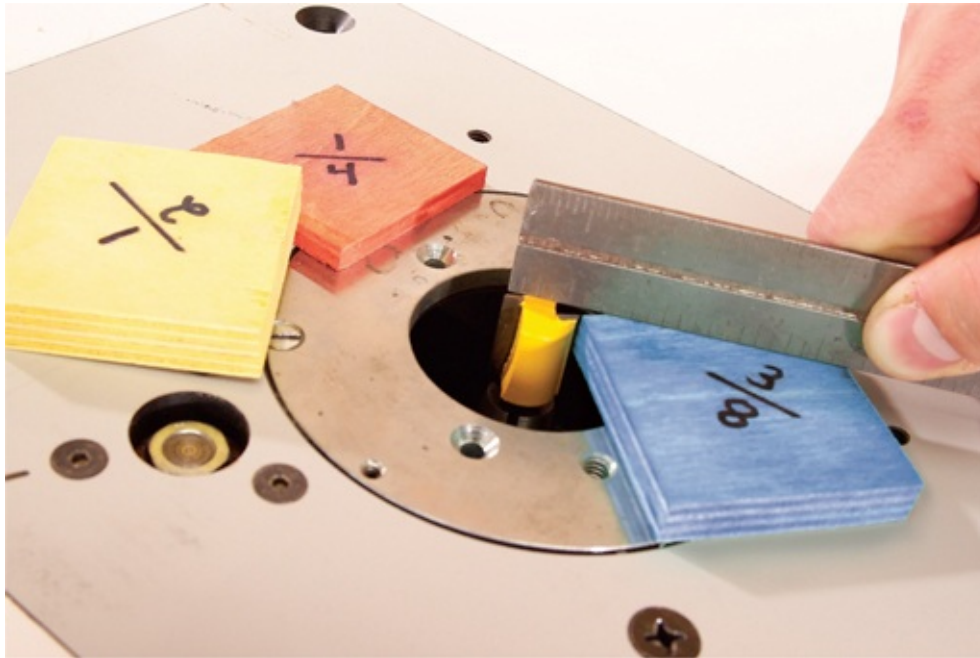

Overhead electrical outlets

Are you always tripping over extension cords that snake all over the floor of your shop? End that hassle by installing ceiling-hung electrical outlets. Place them wherever you frequently need to plug in power tools, vacuum cleaners, steam irons or any other corded tool that you want to plug in right here, right now.

For each one you'll need:

- A metal electrical box
- A metal box cover with a center knock-out
- A strain-relief cord connector
- Electrical connectors
- A cord receptacle
- A short length of stranded-wire electrical cord (buy 12-3 stranded wire for 20-amp circuits and 14-3 for 15-amp circuits).

Position the receptacles at least an inch above your head so you won't bump your noggin. Turn off the breaker or unscrew the fuse on the circuit you're tying in to. And check for voltage with a voltage sniffer to make sure the power is truly off before you splice into the circuit and wire the new receptacles.

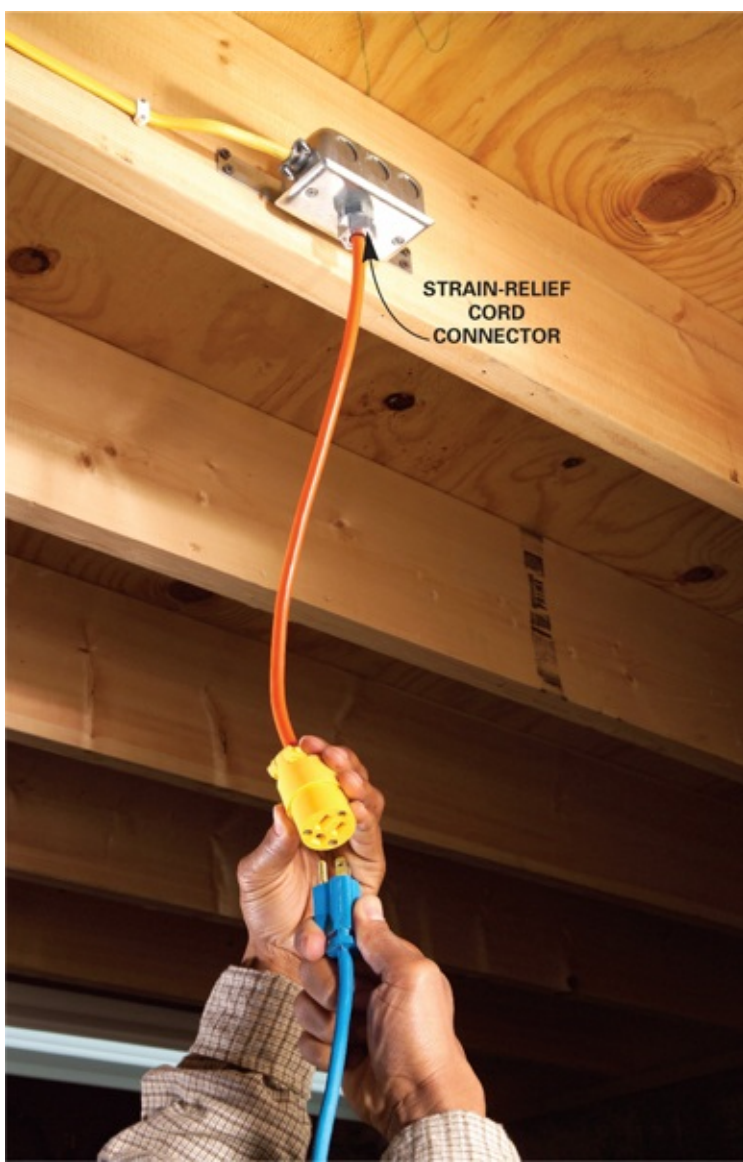

STRAIN-RELIEF
CORD
CONNECTOR

Low-budget ventilation

Stick a plywood insert with a hole for a fan in one window, and in the other window tape a piece of furnace filter material. When you turn on the fan, air is pulled through the fabric, filtered of dust and exhausted through the fan. But even with the good ventilation, still wear a respirator for extra protection.



Super-cool hardware trays

Forget the old coffee can filled with your lifetime collection of screws, washers and other hardware. Take 10 minutes to organize the miscellany in ice cube trays. Nail together a case from scrap plywood and carry it right to the job at hand.



Workshop file crate

Organize all your tool manuals, sandpaper, receipts, project plans and more in a plastic file box loaded with hanging files. If you neatly label the files, the next time you want to take apart the chain saw, or need a piece of 220-grit sandpaper, you won't waste a second rummaging around for the manual or sandpaper.



Easy-peel labels

Here's a slick way to remove those pesky labels from boards and plywood. Heat the label with a hair dryer and peel it off with a putty knife or sharp chisel. Go slow and tug gently and it'll come off in one piece and leave no scraps behind to tease away. Even though the spot will look clean, there will be a little adhesive left on the wood, and the label footprint will reappear the second you put a finish over it. So rub the spot with acetone and sand lightly to remove it completely.



Ventilated shop vacuum attachment

Floor attachments on new shop vacuums have little risers on the bottom edge so the attachment doesn't get glued to the floor by suction, making serious debris pick-up next to impossible. For older attachments without risers, there's an easy fix: Cut 1/4-in.-deep notches every inch or so along the rim with a hacksaw. Now the attachment will slide around without sticking to the floor and clean much more effectively.



In-the-bag calculator

Don't let shop dust, finger grime and shop humidity gum up your calculator's keypad and inner workings. Seal your calculator in a zipper bag. It's easy to see and operate the buttons right through the bag—even during the big dust storm created by your latest project. Go figure!

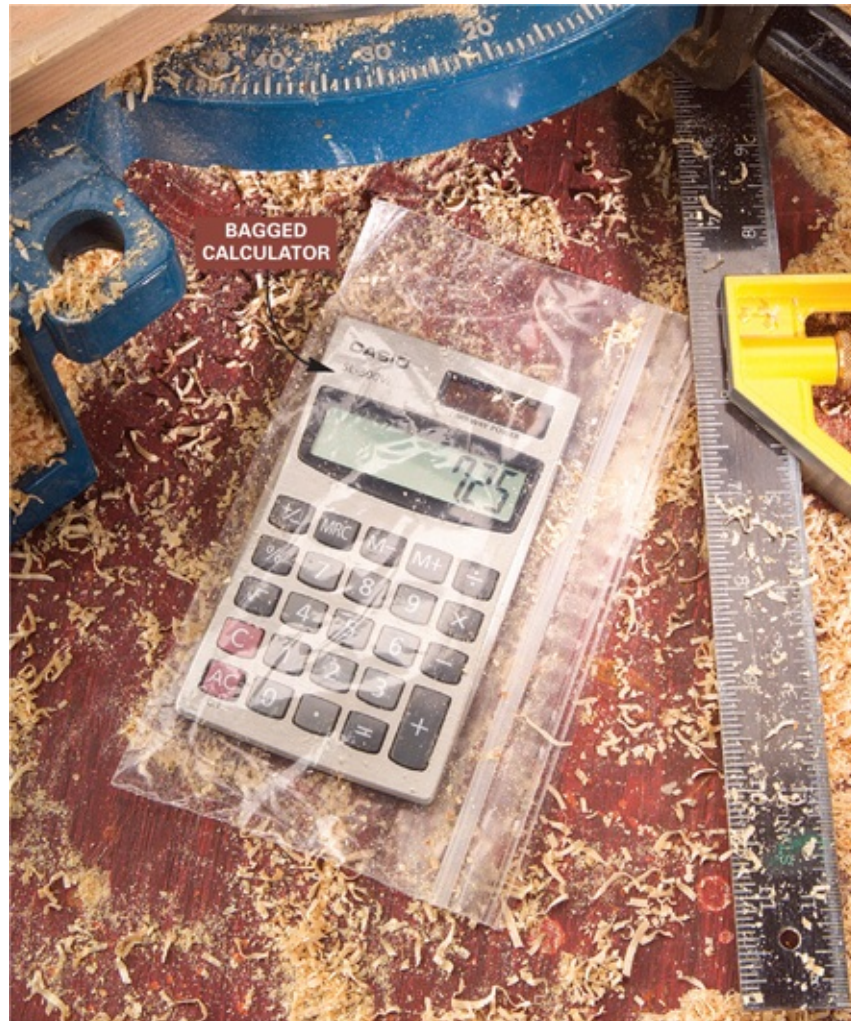

Better shop vacuum handle

As indispensable as shop vacuums are, most of them have one flaw: The handle's built into the lid, and when the tub gets heavy, the lid can pop off when you grab the handle to carry the vac.

Here's a neat fix: Hook the metal ends of a trunk tie-down strap on the vacuum's caster flanges, then adjust the strap to a comfortable length. Now pull up on the strap so it's taut against the sides of the tub, and drill 1/4-in. holes through the strap and the sides of the tub a few inches below the rim. Bolt the strap to the tub with a couple of 1/4-in. x 3/4-in. bolts, nuts and washers.

The new handle lugs a heavily loaded vacuum up and down stairs, falls out of the way while you're vacuuming and creates a convenient loop for storing the coiled vacuum hose.



Never-lose-it chuck key

Attach a spring-loaded key holder to your drill press so the chuck key is always at the ready and impossible to lose. Most key holders come with 20 in. of retractable line with a ring on the end. Link the line and chuck key with a rubber key holder (\$1 at a hardware store) or a few wraps of electrical tape.

Attach the key holder to the drill press housing with metal epoxy, or, if your drill has a plastic cowl over the quill, remove it and drill a hole in the cowl and then bolt on the key holder.

Note: Check for clearance between the key holder and the drill's handle-crank or other movable parts before attaching the key holder to the drill press. AND ALWAYS MAKE SURE THE KEY IS REMOVED FROM THE CHUCK BEFORE TURNING ON THE DRILL PRESS.

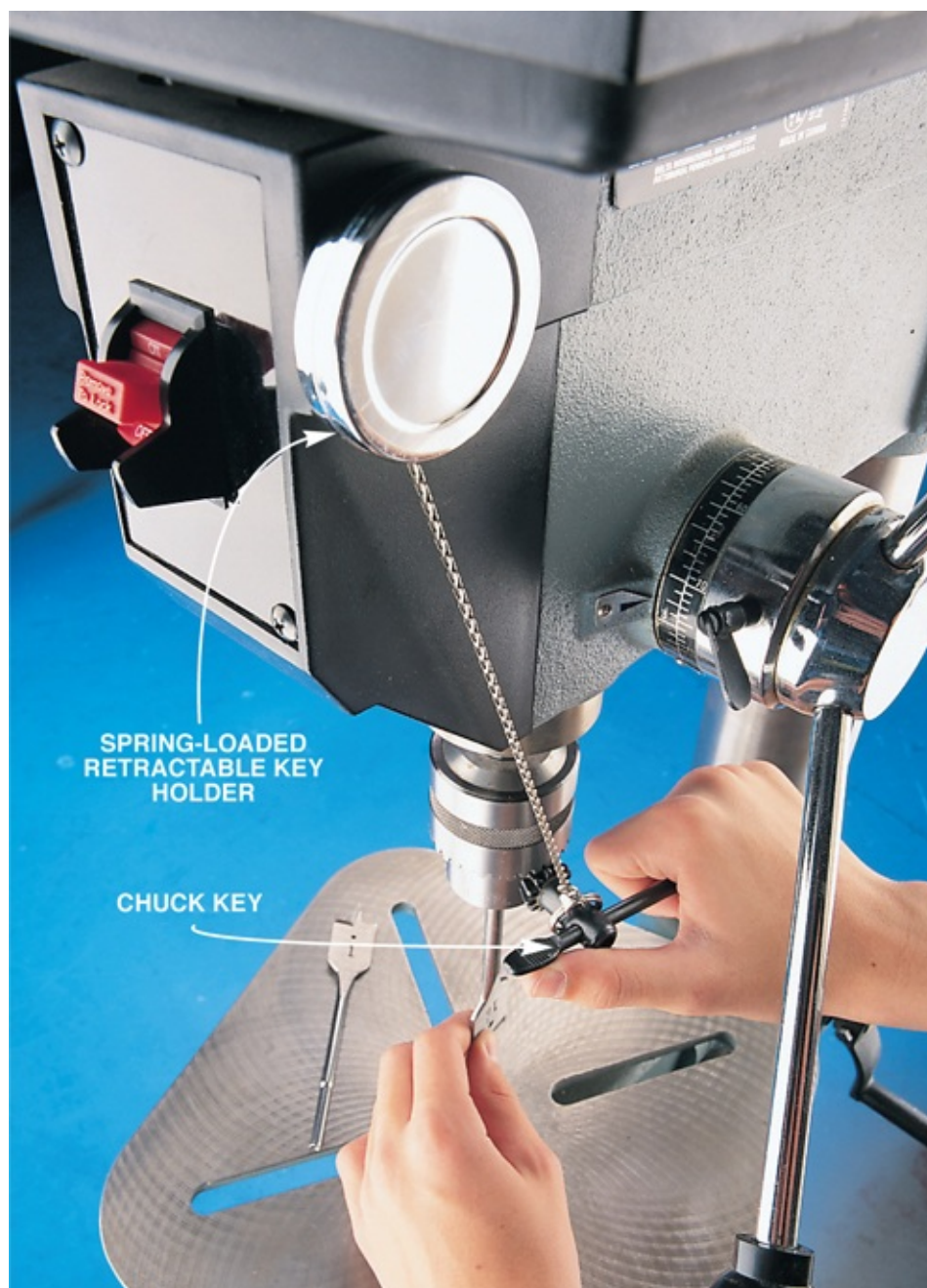

A chain gang of router wrenches

Ever been here, done this? A Saturday afternoon's worth of woodworking creates a pile of tools, bottles, boards, clamps and chips on your workbench. You need a new bit in the router, but a search produces only one collet wrench. Thirty minutes later, sweaty but unbowed, you unbury the second wrench.

To avoid bit-changing rage, use this simple. Buy a pair of small split key rings and a short length of small-gauge chain, and shackle the wandering wrenches into a single, easy-to-hang, hard-to-lose unit. You'll enjoy bit-changing serenity forever.



Adjustable drawer partitions

You can restore order in messy shop drawers with 1/4-in. plywood partitions and weatherstripping. These drawer dividers will organize your tools, tape and twine, and you can easily inch them sideways to accommodate larger items. For the strongest grip, use spongy “closed cell” weatherstripping.

Apply weatherstripping to the sides of the drawers as shown, then cut the partitions long enough so they squish firmly into the rubber on both ends. A good rule of thumb is to make the partitions 1/4 in. longer than the inside measurement between the weatherstripping.

To install a partition, hold it at an angle to the front and back sides, then rotate it into position.



Saw blade carryall

Cut a 14-in. x 12-in. piece of 3/4-in. plywood and drill a hole for a 2-in. x 3/8-in. carriage bolt. Secure the blades on the bolt with a fender washer and wing nut, being careful to stagger the carbide teeth so they don't rub together. Saw a slot in the upper end for a handle and for storing it on pegboard.



Drill bit rack

Here's the Cadillac of drill bit racks. It comes with a sizing index to check round workpieces and the bits themselves for drilling the exact corresponding hole. The length of the rack is up to you—build it to hold all your bits in order of size. You can either build it freestanding for tabletop use or without the base pieces for wall mounting.

To build one, lay your bits—spade and/or twist bits—on a table with 1/2-in. spacing. Cut two 3/4-in. x 3/4-in. strips of hardwood, then mark, clamp and drill according to the bit spacing you determined. (Drill through both strips for spade bits but only halfway through the second strip for twist bits.) Position two 2-3/4 in. blocks between the strips and screw them together. Use the bits you laid out to drill holes in a piece of 1/4-in. plywood for the sizing index. Screw it to the rectangle and get those bits in order!

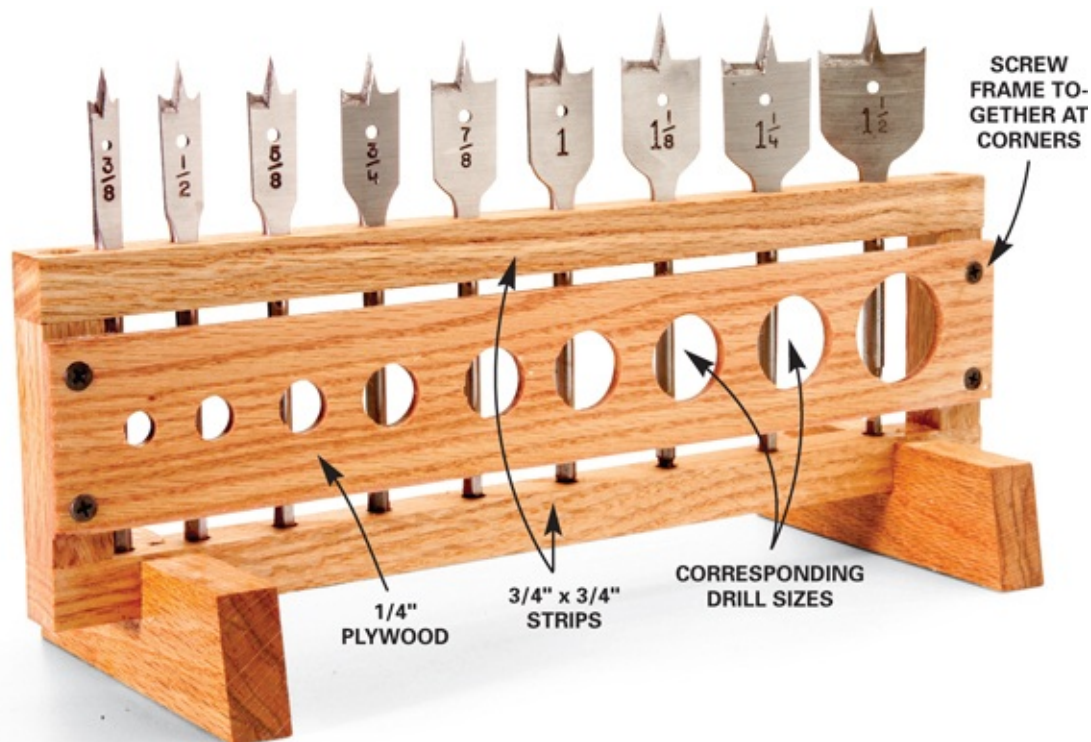

PVC storage hangers

Cut 2-in. pieces of 3-in. PVC and saw away a 2-in. section so it looks like Pac Man. (Remember Pac Man?) Drill screw holes and attach the hangers to studs or shop walls. Space pairs for convenient horizontal storage of longer tools such as levels and glue clamps, and use single segments for ropes, electrical cords or anything else that you want securely stored yet easily accessible. Try this tip and you'll learn never to be peeved by leftover PVC.

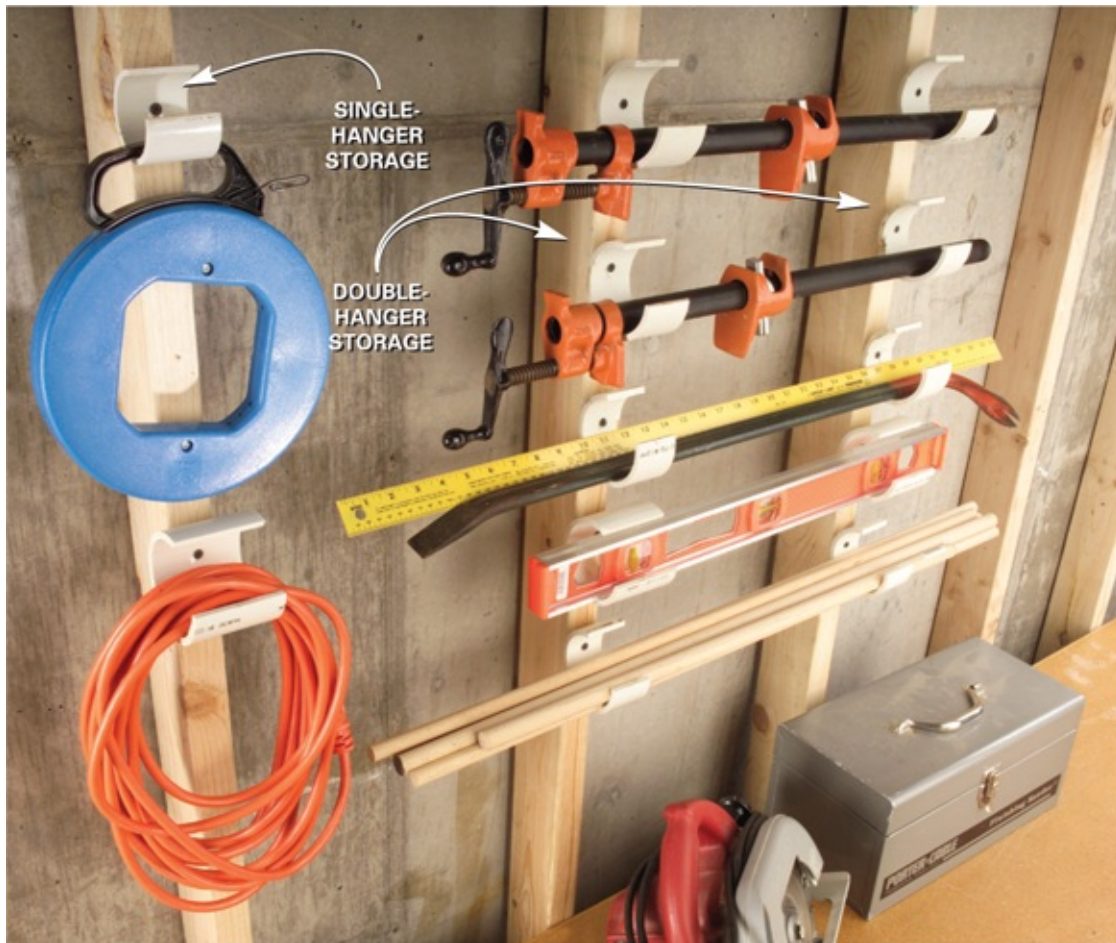

Table saw basket

Here's a solution for keeping all your table saw paraphernalia—push sticks, miter fence, extra blades, wrenches—in easy reach and free of sawdust. Attach a plastic storage basket (\$3 at a home center) under one side of the saw table with four pieces of stout, vinyl-coated wire. Table saw designs vary, but most have predrilled holes in the wing edges, and you may be able to temporarily loosen a couple of bolts under the table, like we did, to twist the wire on and retighten the bolts to hold it. For best storage, add a plywood shelf or two, drilled out with a large spade bit so it won't collect dust. Attach the shelves with 3/4-in. machine screws through the plastic into the plywood.



Caulk tube nest

Cut 10-in. long pieces of 2-in. PVC pipe and glue them side to side with PVC cement. To get straight glue lines, use the print along the side of the pipe as a guide. As you glue, hold the pieces together for 60 seconds with hand pressure or a clamp until the glue sets. Be sure to apply the glue only in a well-ventilated area. Glue on one tube at a time to fit the available space.



Cutlery tray tool chest

Fit a large cutlery tray in your tool drawer to organize the tools so you can see and grab the one you want in a second. The tray is easy to lift out and carry to a job, and if you use a metal mesh tray, dust can't build up between the tools.





CUTLERY
TRAY

HAPPY, TIDY
DRAWER

Hardware oil-ganizer

Save up 12 plastic oil quart bottles, cut away one side with a utility knife, scrub out the oil residue and load them with nails and screws. Build a carrying case from scrap 1/2-in. and 1/4-in. plywood. Then label the bottle caps and slide in the bottles. Add a handle and tote it to your next project.





ADHESIVE LABEL

CUT WINDOW WITH UTILITY KNIFE

Keyhole bar clamp roost

You'll love this bar clamp rack because you can holster the clamps securely without tightening the lower jaw against the rack. Just drop in the clamp and pull it out when needed. Notch the top piece of 1/2-in. ply-wood with the keyhole-shaped cutouts as shown, then screw it to the bottom piece of ply-wood. Make brackets from scrap wood and screw the rack to the wall. These notch dimensions fit the most commonly used bar clamps.



Magnetic bit rack

Mount an 18-in. Magnetic Tool Holder to your drill press's pulley cowl for quick-change bit storage. The tool holder is inlaid with powerful magnetic strips that tightly hold all sizes of bits, plus it's easy to mount. Mark and drill a couple of 1/4-in. holes through the cowl of your drill press. Then use two 1-1/4 in. x 1/8-in. dia. bolts with nuts and washers to attach the holder.

While you're ordering, buy a few extra magnetic tool holders and use 'em elsewhere in your shop to hold chisels, squares, router bits, metal rulers, wrenches and all those easy-to-misplace woodworking accessories.



PVC tool pockets

Cut away the upper open section of 1/2 and 3/4-in. PVC pipe with a hacksaw or band saw, drill a hole, screw the piece on a board, and drop in the tools. If you're using a band saw, slice off the cutaway section from a long length before cutting off the 3-in. holster.



Running water for your shop

No utility sink nearby? Designate a 300-fl.-oz. spigoted Tide laundry soap bottle as your shop's water supply. Thoroughly rinse out the bottle and fill it with fresh water, then set it in a convenient spot. The spigot can release a trickle or a torrent. Put a bottle in our shop and use it every day to moisten rags to clean up glue, freshen sharpening stones and clean your hands.



Corner-on pegboard hooks

Ever had a plane, level or square get dinged up after falling off the pegboard? Never again. Bend an 8-in. long pegboard holder into a corner shape by holding it in a vise and pounding it with a hammer to make the series of right angles. Make one corner to hold the left side of the tool and another to hold the right. Now just hold the tool up to the pegboard and insert the corner peg so it clasps the tool's corner.



Rotary-bit organizer

This rotary-bit organizer may just inspire a renaissance of rotary tool use in your shop. Friction-fit a piece of 3/4-in. plastic foam in a snap-lid plastic food container. Then poke holes in the plastic foam with an awl to hold shafted bits, and slice crevices with a utility knife to hold cutoff discs. Using a spade bit at high speed, drill sockets for larger bits and tube-shape containers. Using a spade bit at high speed, drill sockets for larger bits and tube-shape containers.



File by grit

Organize sandpaper by grit in a handy plastic file box available at office supply stores. Just list the grits on the tabs and you can instantly find the right one. The box is also a good place to store those partially used pieces that often find their way into the trash can prematurely.

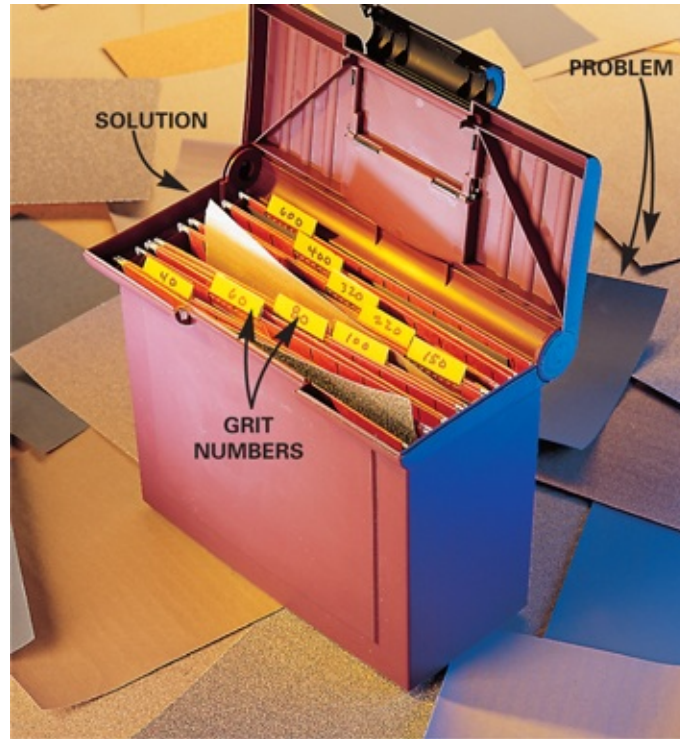

Miter saw table

This simple miter saw table has some great advantages and takes less than an hour to make. Just cut a 21-in. x 96-in. piece of 3/4-in. plywood and screw it to a pair of 8-ft. 2x4s as shown for the base. Mount the miter saw to the base with screws or bolts. Next measure the height of the saw's base and make outfeed tables to the right and left of the saw. Then align a fence with the saw's fence and screw it to the back of the outfeed tables.

Here's how to make the table even more efficient. Buy two adhesive-backed measuring tapes (one right and one left) and trim and stick them to the tops of the fence for making cutoffs without fumbling for a tape measure. Then buy another and align it with the end of the large base for measuring and marking





**LEFT-TO-RIGHT
ADHESIVE-BACKED
MEASURING TAPE**

**RIGHT-TO-LEFT
ADHESIVE-BACKED
MEASURING TAPE**

No-mar horses

You've just got to have a set of sawhorses with carpeted tops for sanding or working with fine pieces of finished wood. Just trim carpeting scraps to size and hot-glue them to the wood tops of your horses. Now you can sand without getting scuff marks on the bottom of the workpiece and assemble prefinished work without leaving marks or scratches.



Dust-proof cell phone dock

Find a plastic container like the one shown and cut it in half. Next, make a wood shelf and back and add a couple of wedges to tilt the phone. Drive a couple of small nails at the base to keep the phone from sliding. You can rivet a hinge to the top of the plastic container and then just screw the hinge to the back of the shelf as shown. The wood shelf acts like a sound board so you can still hear your personal jingle!



Worktop saver

Use a sacrificial worktop tacked to the top of your workbench for those nasty mechanic's chores, metal work, grinding or carving. Just buy a 2 x 4-ft. piece of 1/4-in. hardboard and either tack it to the top with small nails or use double-sided tape to hold it in position. When the rough-and-tumble work is done, you can lift off the temporary top and still have a clean, blemish-free workspace for fine work.



New angle on small tool storage

Find a bare spot on a wall or work-bench and screw on a 2-ft. piece of 2-in. wide, slotted angle iron available at home centers. It's the perfect hangout for screwdrivers, bits, safety glasses and sanding drums. Our thanks to Vic Smith for this simple shop organizer.

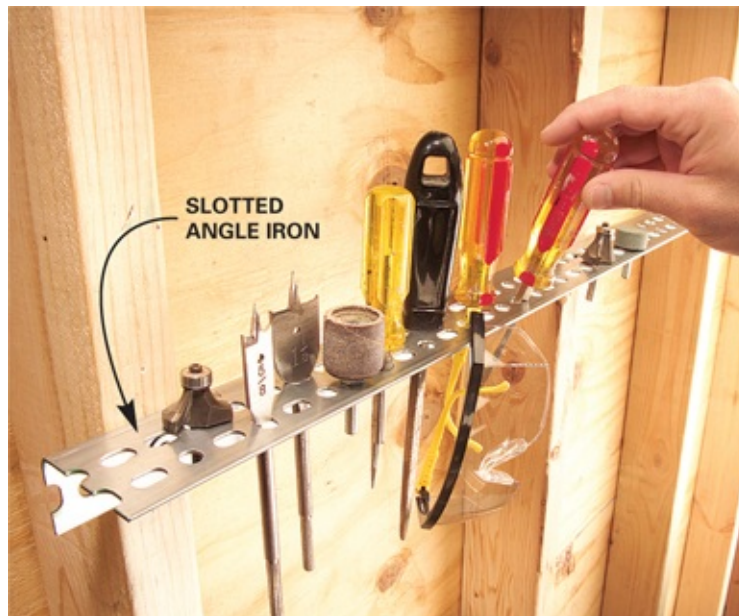

Router-bit story board

On a flat 1-1/2-in.-thick hardwood board, rout profiles and various cutting depths of your favorite bits. Then use that board to (1) set and adjust your favorite cutting depths for rabbet, dado, dovetail, cove, and stile and rail bits; and (2) check out the profile or contour before routing it on a project. Take time to label all the cuts with a permanent marker, and start with an extra-large board that will accommodate both current bits and future purchases.

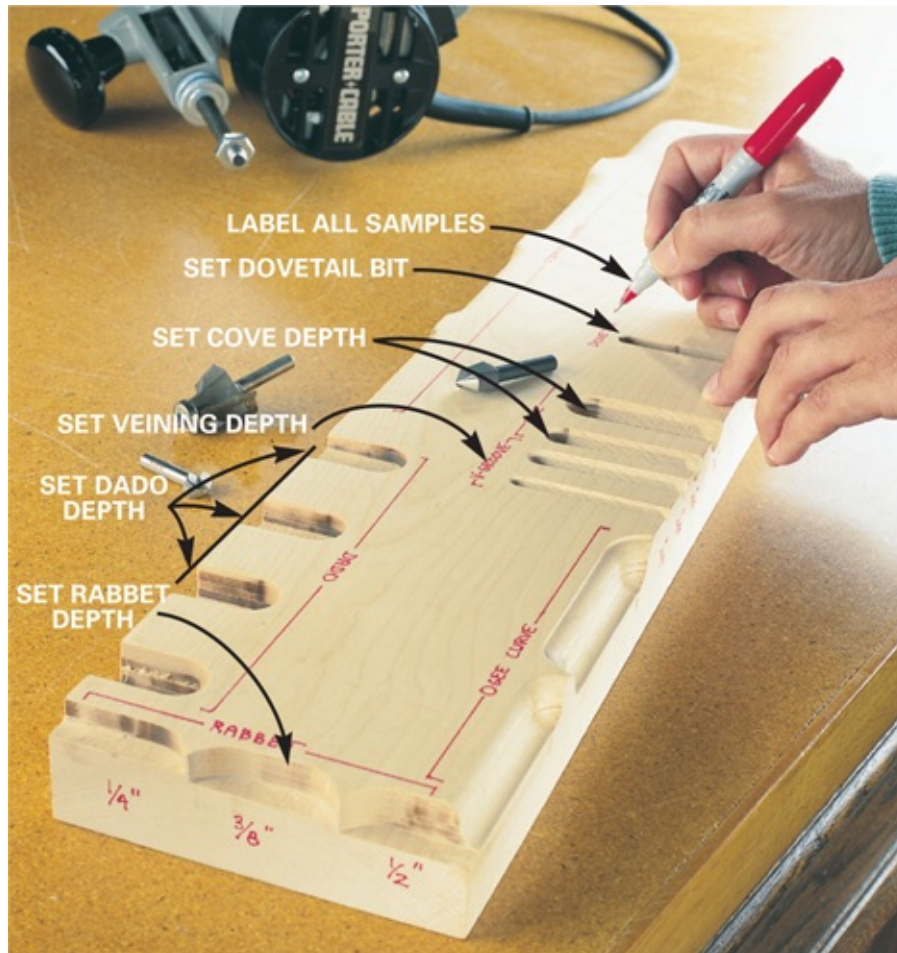

Roll-out workbench dropcloth

Mount a pull-out window shade on one end of your workbench and pull it out for painting projects. Home centers will cut shades to the width you need, so measure your workbench before going to the store. P.S. It's a good idea to wipe wet paint off the shade before rolling it back up.



Power cord coilers

Got a shelf loaded with drills, saws, sanders and routers but can't untangle the cords to safely pull one off the shelf? Buy a pack of elastic ponytail holders and use them to keep the cords neatly coiled while the tools are stored. Snugly loop the ponytail holder around the cord so it stays on the cord while you're using the tool.



Chisel protectors

Holster your chisels and gouges in tennis balls to protect the tips. Just clamp a tennis ball in a vise, cut a slit with a sharp utility knife, and slip the chisel tip inside.



Pegged table saw tools

Are your table saw accessories where you need them—when you need them? Attach pegboard panels to the stand to hold the wandering herd of push sticks, blades, throat plates, wrenches and jigs. On an open metal stand with angle-iron legs, drill holes in the legs and bolt the pegboard in place.

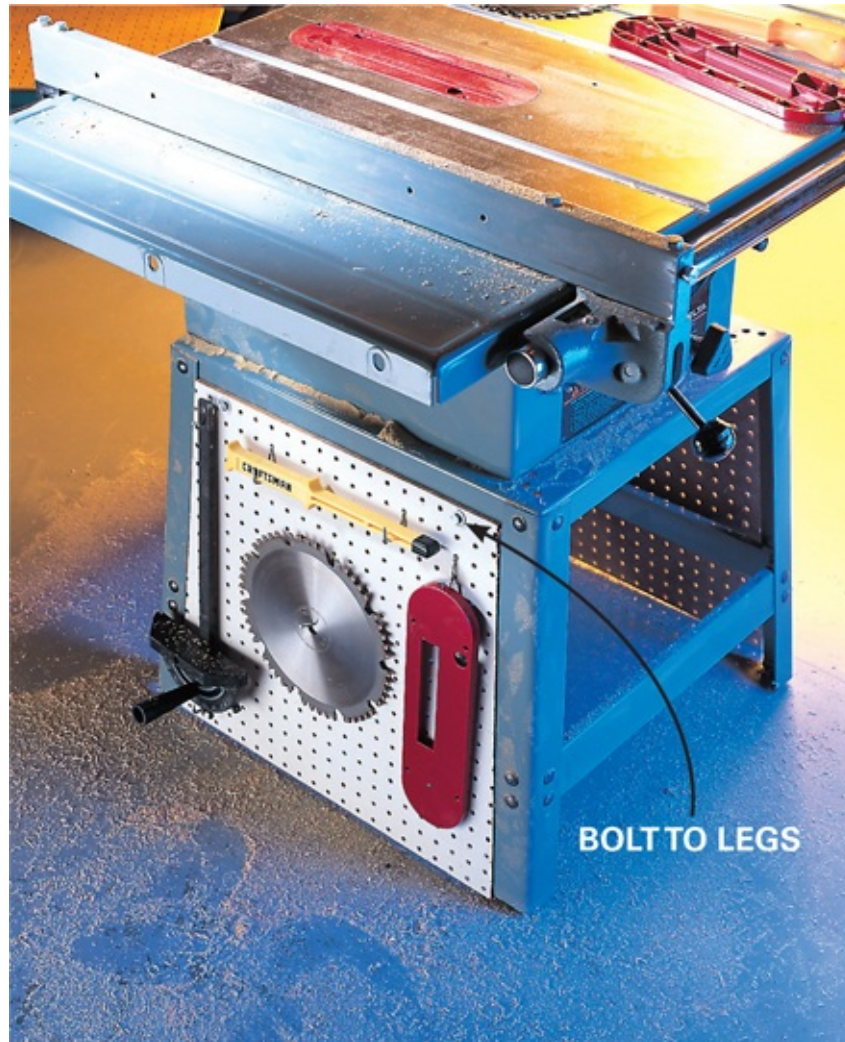

Table saw worktable

Turn your table saw into an extra workbench with a piece of 3/4-in. plywood. Wood strips around the plywood make for a snug, non-slide fit on the metal table. **Two cautions:** Unplug the saw before using it this way, and make sure the saw blade is cranked below the table's surface.



Pipe clamp quivers

A great way to store pipe clamps is in pieces of 4-in.-dia. PVC pipe screwed under your work table. To secure the pipes, use 2-in. lag screws and a socket wrench with a ratchet drive to allow you to reach in the end of the pipes and tighten them.

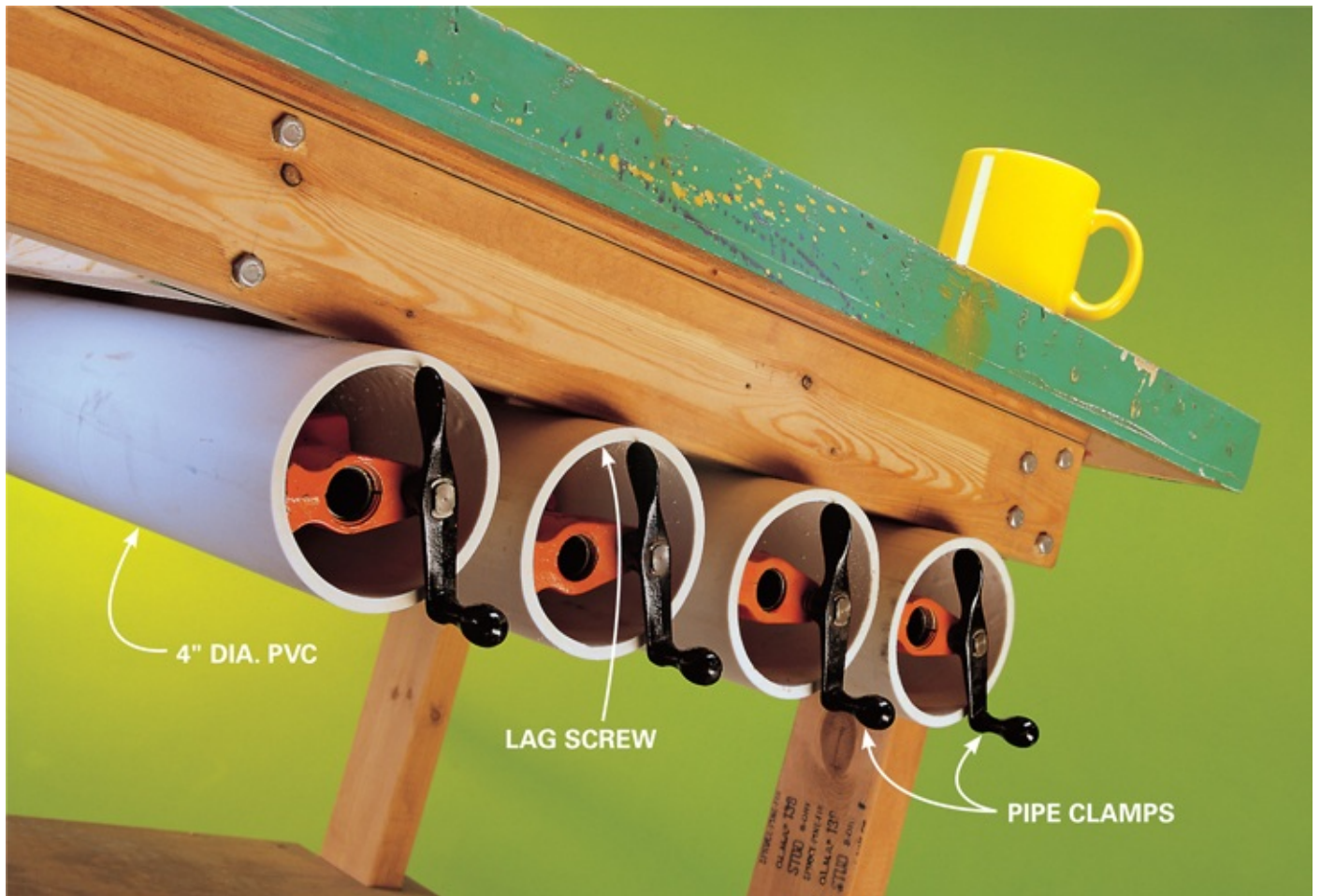

Plans hanger

Hang a pants hanger—the kind with sturdy metal spring clips—on your shop wall to keep plans at eye level and off your dusty workbench!



Router bit storage

A hunk of 2-in.-thick plastic foam makes a great permanent headquarters for router bits and collet wrenches. To drill the shank holes with crisp edges, run your drill or drill press at high speed while pushing down with light pressure. For snug-fitting bits, use a 3/16-in. drill bit for 1/4-in.-dia. router bits, and a 7/16-in. bit for 1/2-in.-dia. router bits. To cut grooves for the wrenches, use your table saw with the blade raised 1/2 to 3/4 in. above the table. You can cut the plastic foam just the right size to fit in a drawer, cabinet or tool chest.

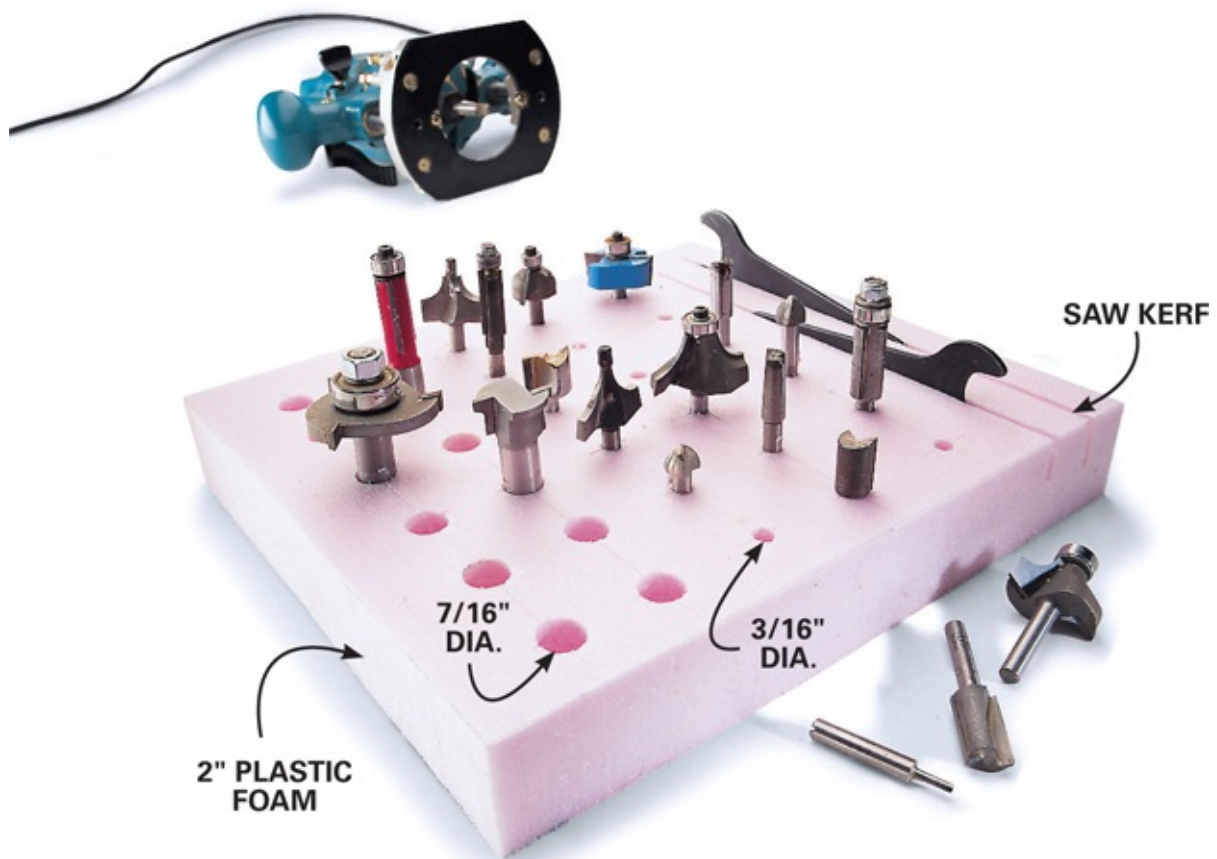

Spring clamp roost

Keep your spring clamps springy for a lifetime! Store them on a metal towel rod so the springs aren't tensed or stressed (or stepped on!). With the towel rod roost, you'll always know where to find these useful clamps in the heat of production.

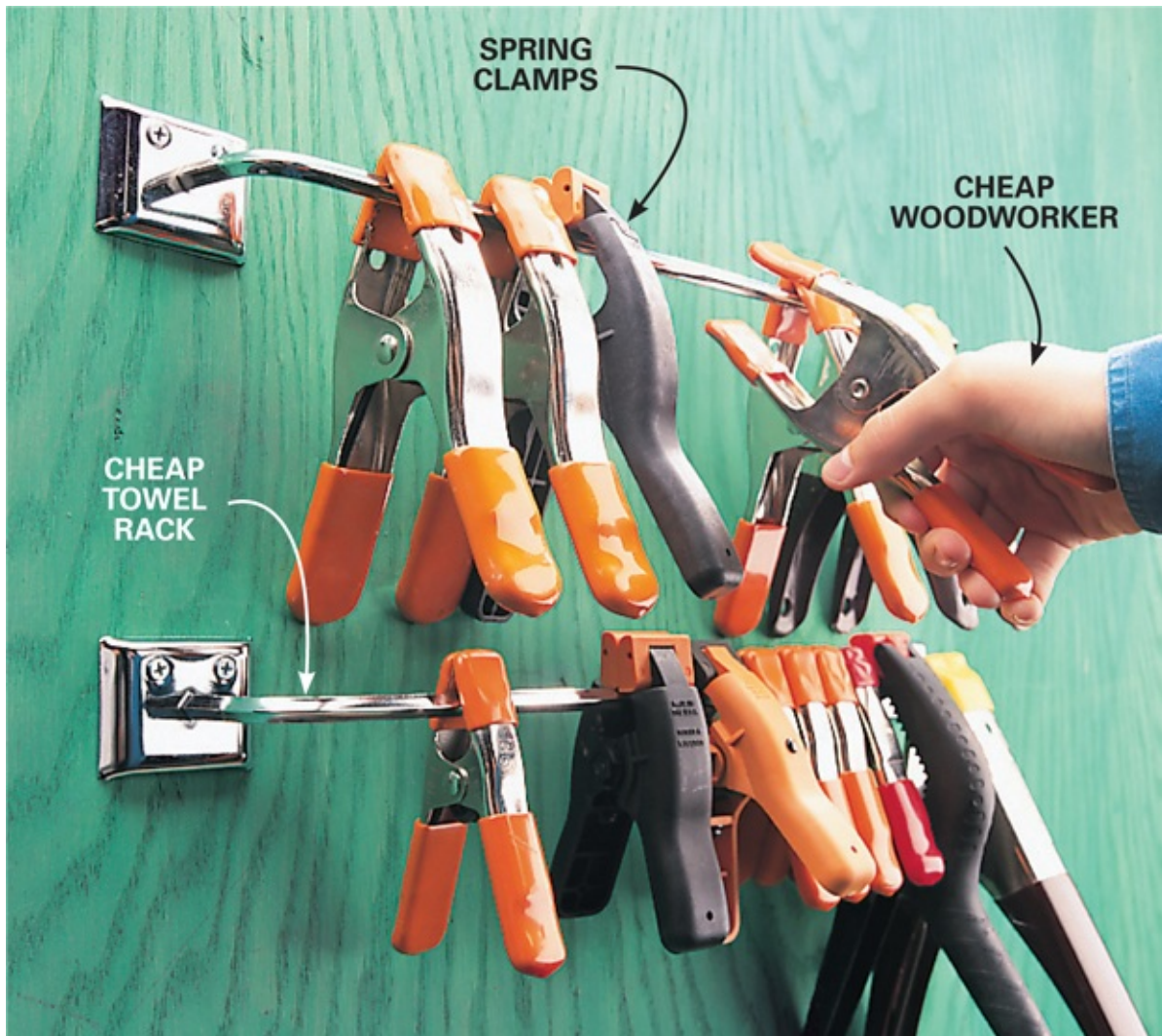

Secure pegboard hooks

Stop pegboard hooks from falling out when you remove the tools by squirting a dab of hot-melt glue in the pegboard hole before sticking the hook in. The glue remains pliable, so if you ever want to move the hook, just yank it out, scrape off the glue with a utility knife and glue the peg somewhere else.

