

10-minute storage solutions!

THE FAMILY #1 in DIY Home Improvement  
**Handyman.**

# 870 HANDY Home Hints

Quick fixes for  
20 things that  
always break

38 tips for  
a healthy,  
weed-free yard

Get a **MORE  
ORGANIZED  
KITCHEN**

22 quick &  
easy tips!

77 speed-  
cleaning tips for  
bathrooms, kitchen & more

10 ways to save up to  
\$2,000 a year at the gas pump

125 secrets for your  
best garden ever



SIMPLE  
MEASURING  
CUP & SPOON  
HOLDER

QUICK  
WINE GLASS  
HANGER

Back by  
Popular  
Demand!



2-HOUR  
SPICE RACK

1-HOUR  
CABINET  
DIVIDERS

NO-COST  
PLASTIC BAG  
HOLDER

Improve your home's  
curb appeal for less than \$99

TIPS FOR A FAST, MESS-FREE PAINT JOB

The Family  
Handyman

# 870 HANDY Home Hints

#### Editorial and Production Team:

Elisa Bernick, Donna Bierbach, Steven Charbonneau, Roxie Filipkowski, Jeff Gorton, Rick Muscoplat, Becky Pfluger, Mary Schwender, Bob Ungar, Bruce Wiebe, Marcia Wright Roepke

#### Photography and Illustrations:

Tom Fenenga, Bruce Kieffer, Mike Krivit, Don Mannes, Ramon Moreno, Shawn Nielsen, Frank Rohrbach III, Eugene Thompson

Cover image by Tom Fenenga

Text, photography and illustrations for *870 Handy Home Hints* are based on articles previously published in *The Family Handyman* magazine (2915 Comers Dr., Suite 700, Eagan, MN 55121, familyhandyman.com). For information on advertising in *The Family Handyman* magazine, call (646) 293-6150.

*870 Handy Home Hints* is published by The Reader's Digest Association, Inc. © 2015 The Reader's Digest Association, Inc. All rights reserved. This volume may not be reproduced in whole or in part without written permission from the Publisher. Reader's Digest and the Pegasus logo are registered trademarks of The Reader's Digest Association, Inc. The Family Handyman is a registered trademark of RD Publications, Inc.

#### A Note to Our Readers:

All do-it-yourself activities involve a degree of risk. Skills, materials, tools and site conditions vary widely. Although the editors have made every effort to ensure accuracy, the reader remains responsible for the selection and use of tools, materials and methods. Always obey local codes and laws, follow manufacturer instructions and observe safety precautions.

Published by Home Services Publications, Inc.  
A subsidiary of The Reader's Digest Association, Inc.

PRINTED IN THE UNITED STATES OF AMERICA

#### • THE FAMILY HANDYMAN

- **Editor In Chief** Ken Collier
- **Project Editor** Brett Martin
- **Associate Editor** Mary Flanagan
- **Senior Editors** Travis Larson, Gary Wentz
- **Administrative Manager** Alice Garrett
- **Page Layout** BatScanner Productions, Inc.
- **Proofreader** Peggy Parker
- **Production Manager** Leslie Kogan
- **Vice President, Group Publisher** Russell S. Ellis

---

#### • THE READER'S DIGEST ASSOCIATION, INC.

- **President and Chief Executive Officer** Bonnie Kintzer
- **Vice President, Chief Operating Officer** Howard Halligan
- **Chief Revenue Officer** Rich Sutton
- **Publishing Director, Adult Trade Books** Debra Polansky
- **Vice President, Product and Brand Marketing** Beth Gorry
- **Vice President, Chief Marketing Officer** Leslie Doty
- **Senior Vice President, Global HR & Communications** Phyllis E. Gebhardt, SPHR
- **Vice President, Consumer Marketing Planning** Jim Woods
- **Senior Director, Product Management** TJ Mancini

# 870 HANDY Home Hints

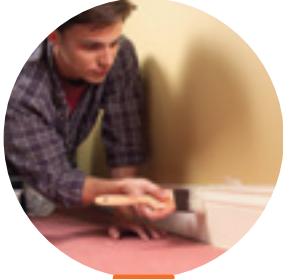

5

**SECTION 1**  
Hassle-free painting



18

**SPECIAL SECTION**  
Instant makeovers



21

**SECTION 2**  
Get organized



32

**SPECIAL SECTION**  
Fast & easy storage



89

**SECTION 5**  
Add curb appeal



100

**SPECIAL SECTION**  
Safety & security



103

**SECTION 6**  
Tips for everyday life



118

**SPECIAL SECTION**  
Cut kitchen & bath chores

table of



**35**

**SECTION 3**

**Money-saving tips**



**54**

**SPECIAL SECTION**

Save energy



**59**

**SECTION 4**

**Backyard living**

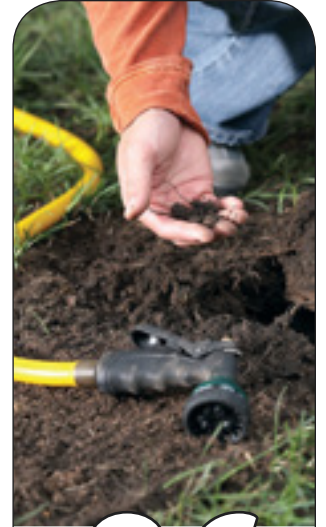

**86**

**SPECIAL SECTION**

Lawn care made easy



**121**

**SECTION 7**

**Clean (almost) anything**



**130**

**SPECIAL SECTION**

Extraordinary uses for ordinary things



**135**

**SECTION 8**

**Tool and workshop tips**

# contents



# Do it right. Do it yourself.

## Learn how to improve your home the right way, at the

# THE FAMILY Handyman **DIY University**



Loads of easy-to-follow how-to videos!

Take online courses on how to do electrical projects safely, master the art of trim, be your own plumber, save money on owning a home, and many other practical topics. All backed by the expertise and clarity you've come to expect from The Family Handyman.

You can learn at your own pace on your computer, tablet or phone. The great how-to videos, step-by-step instructions and interactive photos make the information come alive. With many of the courses, you can even email the instructors for personal, one-on-one help.

**Expert instructors from The Family Handyman can help you with your projects.**

Become a better DIYer! Visit us today at [www.familyhandyman.com/diuniversity](http://www.familyhandyman.com/diuniversity)



# THE FAMILY Handyman



1

# Hassle-free painting



This chapter offers more than three dozen tips to make your painting projects go faster and smoother while giving you a professional-looking finish that you'll be proud of. You'll also find ingenious tips that can cut your cleanup time in half and ensure a long life for your paintbrushes.

# 10 tips for a perfect paint job

## 1 To avoid lap marks, roll the full height of the wall and keep a wet edge

Lap marks are those ugly stripes caused by uneven layers of paint buildup. They occur when you roll over paint that's already partly dry. (In warm, dry conditions, latex paint can begin to stiffen in less than a minute!) The key to avoiding lap marks is to maintain a "wet edge," so each stroke of your roller overlaps the previous stroke before the paint can begin to dry.

To maintain a wet edge, start near a corner and run the roller up and down the full height of the wall, moving over slightly with each stroke. Move backward where necessary to even out thick spots or runs. Don't let the roller become nearly dry; reload it often so that it's always at least half loaded. Keep the open side of the roller frame facing the area that's already painted. That puts less pressure on the open side of the roller, so you're less likely to leave paint ridges.

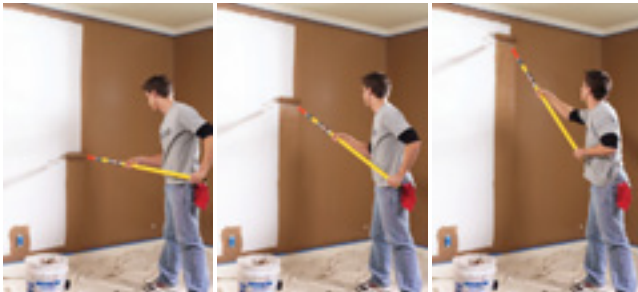

## 2 Mix several cans of paint in a large bucket for a consistent color throughout the room

Paint color may vary slightly from one can to the next. If you have to open a new can in the middle of a wall, the difference may be noticeable. Mixing the paints together eliminates the problem. It's best to estimate the amount of paint you'll need and mix it in a 5-gallon bucket (a process called "boxing"). When coverage is difficult to estimate, add more rather than less. You can always pour the leftover back into cans.

For large jobs, use the bucket and a roller screen rather than a roller tray. It's much faster to load your roller with the screen than to use a roller pan. Simply dunk the roller into the paint bucket, then roll it along the screen until it stops dripping.



## 3 Let the paint dry, then cut the tape loose for a perfect edge

Once paint is dry, you can't just pull the tape off the trim. Paint forms a film between the wall and the tape, and removing the tape tears pieces of dried paint off the wall. So before pulling off the tape, cut it loose.

Wait for the paint to completely dry, at least 24 hours, then use a sharp utility knife or box cutter knife to slice through the film. Start in an inconspicuous area to make sure the paint is hard enough to slice cleanly. If you cut the paint while it's still gummy, you'll make a mess. As you cut the paint, pull up the tape at a 45-degree angle.



## 4 Paint the trim first, then the ceiling and walls

Pros usually follow a certain order when painting a room. They paint the trim first, then the ceiling, then the walls. That's because it's easier (and faster) to tape off the trim than to tape off the walls. And you certainly don't want to tape them both off!

When painting the trim, you don't have to be neat. Just concentrate on getting a smooth finish on the wood. Don't worry if the trim paint gets onto the walls. You'll cover it later when painting the walls. Once the trim is completely painted and dry (at least 24 hours), tape it off (using an "easy release" painter's tape), then paint the ceiling, then the walls.

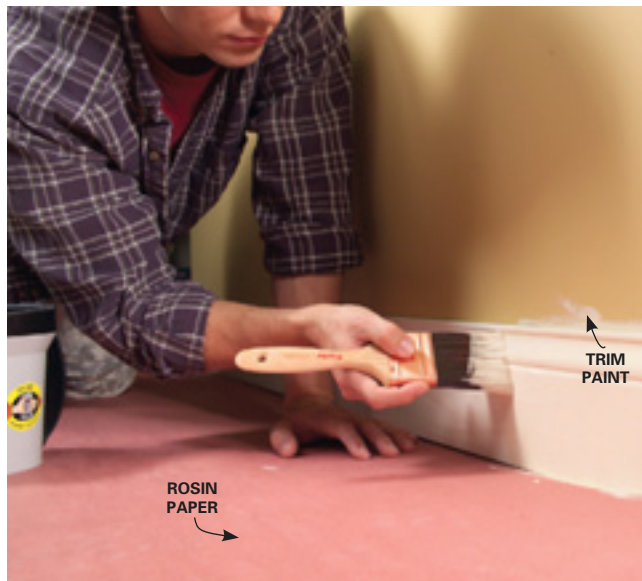

## 5 Prime and texture wall patches to avoid a blotchy finish

Freshly painted walls often look blotchy. The color is uniform, but the sheen isn't consistent. This usually occurs over the holes and cracks you patched with a filler or drywall compound. The porous fillers absorb the paint, dulling the surface (a problem called "flashing"). When light hits these dull spots, they stick out like a sore thumb. The smooth patch also stands out in contrast to the slightly bumpy texture of the rest of the wall. A quick coat of primer is all it takes to eliminate flashing and texture differences.

Primer seals the patch so paint won't sink in and look dull. To match texture, prime with a roller, feathering out the edges. Choose a nap thickness to match the surrounding wall texture (a 3/8-in. nap roller for smooth walls; 1/2-in. for textured).



## 6 Clean dirty surfaces so the paint can form a strong bond

If you paint over dirty, oily surfaces, the paint will easily chip or peel off. So before painting, clean grimy areas with a deglosser or heavy-duty cleaner intended for prepaint cleaning. They work well to clean painted, varnished or enameled surfaces to improve the adhesion of the new paint. They're ideal for cleaning greasy or oily areas like kitchen and bathroom walls and removing hand marks around light switches and doorknobs.

Wipe on the cleaner in a circular motion using a lint-free cloth or abrasive pad. Start at the bottom and work up. After the surface is clean, fill in any nicks and holes, then sand them smooth before painting. The cleaners are available at paint stores and home centers. Be sure to wear rubber gloves and eye protection.





## 8 Use cotton drop cloths rather than plastic

Spills and splatters happen, regardless of how careful you are. It's a lot easier to prepare for them than to wipe them out of your carpeting or off your wood floor later. All it takes is canvas drop cloths in your work area (a 4-ft. x 15-ft. cloth costs \$15). The thick canvas stays in place, so you don't need to tape it, and you can use it to cover any surface. Plastic drop cloths are slippery to walk on or set a ladder on and don't stay in place. Even worse, paint spills on plastic stay wet, and they can end up on your shoes and get tracked through the house. Canvas is slippery on hard floors, so rosin paper (\$10 for 400 sq. ft. at home centers) is better over vinyl, tile and hardwood. Tape the sheets together and to the floor to provide a nonslip surface.

But even with canvas or rosin-paper drop cloths, large spills still need to get wiped up right away or they'll seep through. Clean spills with paper towels or cloth rags. Likewise, if you splatter paint on any other surface, wipe it up immediately.



## 7 Roll paint along the edges for consistent texture

Corners and areas next to trim that are painted only with a brush have a noticeably different texture than the surrounding paint. To ensure the finished texture will be consistent in these areas, brush on the paint, then immediately roll it out before the paint dries.

Use a 3-in. roller with a nap that's the same thickness as the roller used for the rest of the wall. Roll as close as you can without bumping the opposite wall or slopping paint onto the trim. Finish brushing on the paint and rolling it out in one area before moving on to the next section.

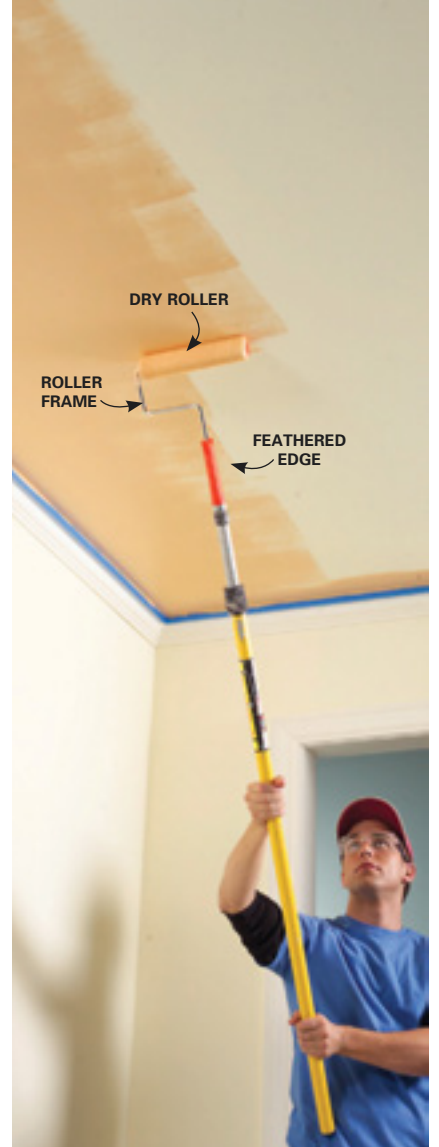
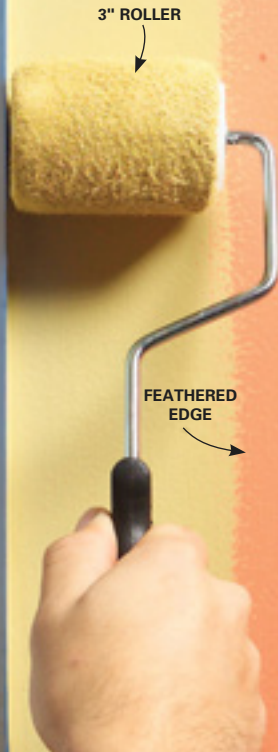

## 9 Feather out paint where you can't keep a wet edge

You can't cover large areas like ceilings, extra-tall walls or stairwells in single, continuous strokes, so the best way to minimize lap marks on these areas is to feather out the paint along the edges that you can't keep wet. The thinner, feathered coat of paint will avoid the buildup that causes the lap mark.

To paint a large section without leaving lap marks, roll the nearly dry roller in different directions along the dry edge, feathering out the paint as you go. After completing the entire length of the wall or ceiling, move to the next section and paint over the feathered edges. For the second coat, apply the paint in the opposite direction. This crisscrossing paint application sharply reduces (if not eliminates) lap marks.

# 10 Sand trim between coats for an ultra-smooth finish

One coat of paint usually won't hide the underlying color and sheen on trim. And if you don't sand the surface smooth between coats, the finish may have a grainy texture. For a smooth finish, sand the trim before applying each coat of paint.

Sand the trim with a fine-grit sanding sponge. Sponges get into crevices where sandpaper can't go and let you apply even pressure. Then apply the first coat of paint, let it dry at least 24 hours, lightly sand it again for a completely smooth surface, and apply the second coat. After each sanding, vacuum the trim, then wipe it down with a tack cloth to remove the dust.



## 4 ways to avoid lap marks

Ridges of paint left by the edge of the roller, or lap marks, are a common problem. And if left to dry, they can be difficult to get rid of without heavy sanding or patching. Here are four ways to avoid the problem:

- Don't submerge the roller in the paint to load it. Paint can seep inside the roller cover and leak out while you're rolling. Try to dip only the nap. Then spin it against a screen and dip again until it's loaded with paint.
- Don't press too hard when you're smoothing out the paint.
- Never start against an edge, like a corner or molding, with a full roller of paint. You'll leave a heavy buildup of paint that can't be spread out. Starting about 6 in. from the edge, unload the paint from the roller. Then work back toward the edge.
- Unload excess paint from the open end of the roller before you roll back over the wall to smooth it out. Do this by tilting the roller and applying a little extra pressure to the open side of the roller while rolling it up and down in the area you've just painted.

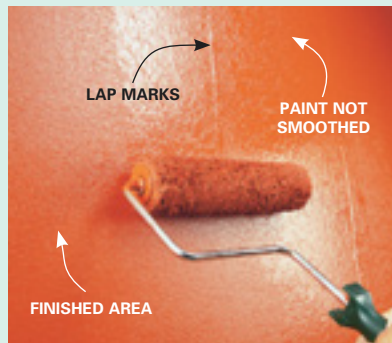

**Smooth walls by rolling back over the wet paint without reloading the roller. Roll lightly without pressing.**

## Paint pad for tight spots

If you have a tight spot to paint, remove the pad from a paint edging tool (about \$2 at home centers). Hot-glue the pad to a stir stick, and you've got a painting tool that will fit behind toilet tanks and radiators.



## Double the life of your paintbrushes

To ensure you get a lifetime of use out of your synthetic paintbrushes, clean each one immediately after using it, before the paint has a chance to dry. Start by wiping the brush on newspaper to remove excess paint. Then stick the brush into a bucket of warm water (Photo 1). Move the brush around to remove as much paint as possible. Next, hold the brush under running water. Run a wire brush (or a kitchen fork) down the bristles to remove dried paint, especially near the handle (Photo 2). When the water running off the bristles turns clear, the brush is clean.

Let each paintbrush air dry, then wrap it with the cardboard cover it came in or heavy paper (like grocery bag paper). To keep the bristles straight, hang the brushes from a nail or hook, or store them flat.



**1** Move the paintbrush around in a bucket of water to wash out the paint, then run it under water.



**2** Use a wire brush to remove the paint from the bristles.



## Mess-proof painting

The plastic-wrapped case that holds 24 bottles of water is a perfectly sealed tray for your paint cans, brushes and trays. Sloshed or dripped paint won't spill onto a drop cloth and be tracked all over the house. When you're opening the water bottle package, cut the plastic about 5 in. higher than the top of the box and then fold it in.



## Pimple pads for paint cleanup

Facial cleansing wipes aren't just for pimple prevention. The alcohol in them softens latex paint, but won't harm most surfaces (test first to make sure). They work best on paint that's been dry just a few hours.



## Overnight paint storage

If you can't finish your paint project in one day, you can clean all the tools and start over the next morning or wrap your paint tray in a bag overnight to keep the paint and roller fresh. You can also try a third option: Get the SealPro Resealable Paint Tray. The attachable lid seals the tray, protecting the paint and roller from drying out while you snooze. That way, you don't have to hassle with cleanup until the job's done.

The rigid tray doesn't tip easily and holds up to a gallon of paint. A magnet on the side of the tray holds brushes upright so they're grabbable and keeps the handle out of the paint. Buy the tray at hardware stores and online.

**SealPro Products**



## Cardboard spray booth

Prevent paint “overspray” with this clever spray booth made from a cardboard box. Cut a hole in the top of the box. Cover the opening with plastic wrap and position a shop light above to illuminate your project.

You can use coat hangers, poked through the cardboard, to hold and rotate the objects as you’re painting them. Not only will your shop be neater, but your paint projects will now be thumbprint free.

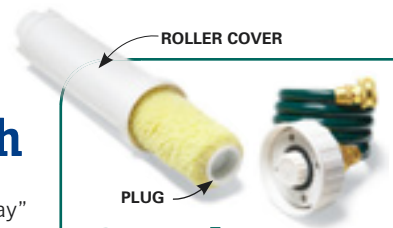

## Speedy roller cleaner

The Rejuv-a-Roller is so easy to use that you won’t mind cleaning roller covers. Instead of buying cheap roller covers and throwing them away, you can buy top-quality covers and reuse them. Here’s how it works: Slip the roller cover into the tube and plug the end. Then connect the hose to a faucet and turn on the water. When the water runs clear from the bottom holes, the roller is clean. If you own a roller spinner, you can speed up drying and fluff the roller nap by giving it a quick spin. But it’s not necessary. For more information, search online for Rejuv-a-Roller.

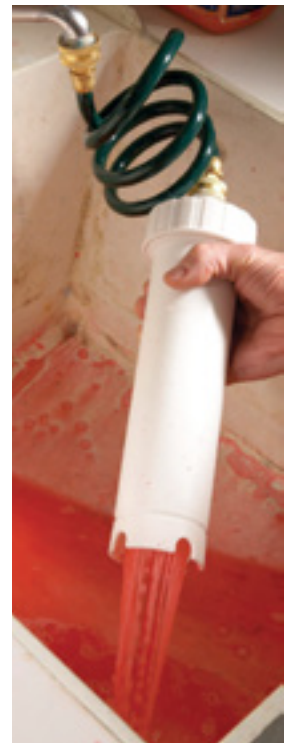

## Lint-free paint roller

Cheap paint rollers shed all over the paint as you roll it on, but they’re good because they’re disposable—no cleanup! Before using one, wipe it with a self-adhesive lint roller to remove all the loose fuzz—no more picking it off wet walls.



## Painter’s reminder

When you’re finishing a painting project, write on a piece of masking tape the date and how many gallons of paint were needed for the job. Stick the tape to the back of the light switch plate. To get the exact shade next time, also include the color formula sticker peeled off the paint can. When the room’s due for a fresh coat, you’ll be ready to go.





## Fill gaps with paintable caulk

Sand the walls with 100-grit sandpaper to remove bumps from the old paint job, rough edges of drywall paper around any gouges and any other imperfections. A drywall sander will make the job easier. Sand primed woodwork with a medium-grit sanding sponge. Fill any wall blemishes such as nail holes and gouges with a nonshrinking spackling compound and lightly sand after they're dry. Dust all the woodwork with an old, soft paintbrush or duster. Caulk all wall/woodwork joints with a paintable white silicone/latex caulk. Cut a small (1/8-in.) hole in the end of the nozzle. Wipe off excess and smooth caulk beads with a damp synthetic sponge.

## Brush ceiling edges

Cut in the perimeters of ceilings with ceiling white and a 3-in. brush. Don't worry if you lap over onto the wall. Roll on a second coat of ceiling paint in the opposite direction of the first coat.



## Roll-on stainless steel

Apply Liquid Stainless Steel to your kitchen appliances and you'll have the stainless steel look without having to buy new (it's great for giving aging appliances a face-lift!). The water-based latex paint is made with stainless steel and applied with foam brushes and a roller (included with paint purchase). A topcoat gives the surface a durable satin or gloss finish (your choice).

The paint can be used on stoves, refrigerators, dishwashers and toasters—just clean them up, tape off the areas you don't want covered and start painting. You can apply both coats and the satin or gloss topcoat in a morning. The paint can also be used on kitchen cabinets, tables and chairs (after priming). One quart of the base coat is enough to cover an average-size refrigerator with the required two coats. Retailers are listed online, or buy the products directly from the manufacturer.

**Thomas' Kitchen Art**



## Door painting revolutionized



If you have a door that needs painting, you'll flip for this tip. You'll be able to paint both sides of the door without waiting for the first side to dry. Rest the door on sawhorses and drive a 1/4-in. x 2-1/2-in. lag screw into each corner of one end and another in the middle of the other end for a pivot.

Slide the sawhorses to each end of the door so the screws rest on the edges of the sawhorses. Paint one side of the door and then, using the two screws as handles, lift and rotate the door on the pivot screw to expose the unpainted side.



PIVOT POINT

## Self-stick paint shield

Glad Press'n Seal plastic wrap goes on fast and stays right where you put it. Paint can seep under the edges, though, so it's no substitute for masking tape in spots where you need a sharp edge.



## Tape with a knife

Tape all wall/woodwork seams with painter's tape. Lay the tape onto the woodwork and press it with the corner of your putty knife to prevent the wall paint from bleeding behind the tape onto the woodwork. Let the tape stick out perpendicular to the trim to act as a little protective roof to catch paint drips.



## Self-sealing paint cans

Store paint cans upside down and the paint will form an airtight seal around the rim. Make sure the cover is on tight to prevent leakage. Hold the can upright and shake it vigorously before you open it so the solids in the paint drop off the lid.



## Brush for cleaning brushes

An old golf club brush is perfect for scrubbing off that crusty coat that builds up on paintbrushes. The plastic bristles scour away most of the crust without harming the brush. The brass bristles will take care of the stubborn spots.

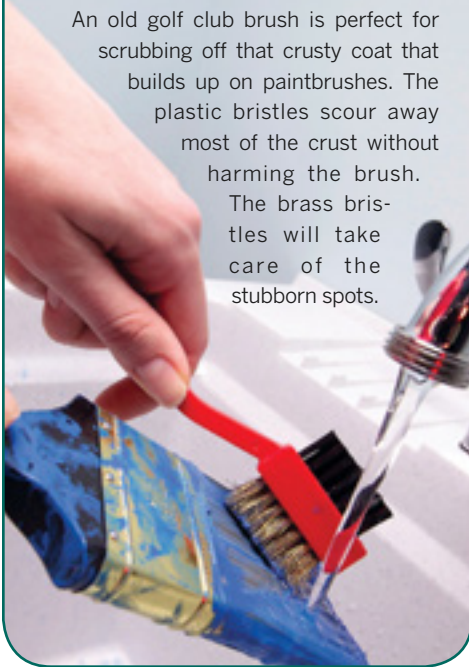

## Scrape away ceiling texture

A neat, straight paint line at the top of a wall is tough to achieve next to a bumpy ceiling. So before you paint, drag a narrow flat-head screwdriver lightly along the ceiling. You'll get a clean paint line and no one will ever notice that the bumps are missing.



## Spray paint revives old upholstery

For less than \$20, you can make an old chair look like new. Special spray paint formulated for fabric can hide stains, update the color of old solid-color upholstery and even obscure minor wear. It's available at most auto parts stores and some home centers and hardware stores. Most stores carry only two or three colors. To find more colors, do an online search for "fabric spray paint."

Fabric spray paint has one drawback: It can make fabric feel rough. This usually isn't a big problem with smooth fabrics, but fabric with a "nap," such as velour, may feel like sandpaper after painting. Test the back of a chair or the underside of a seat cushion before you paint the entire piece.



## Fresh tape

Sometimes, masking tape that's been sitting on a shelf for years won't pull off the roll without tearing. Freshen it by microwaving it for 10 seconds. Heat softens the adhesive for easy release.



## Edge-trim your paint roller

Those ragged edges and tiny beads of dried paint on your paint roller may seem harmless, but they'll leave ugly tracks in your paint job. Trim them off, leaving a slightly tapered edge, and your roller will be as good as new.



## Elevate—then paint

Ever paint a chair and have it stick to your newspaper or drop cloth? Paint hassle-free by driving drywall screws about 1/2 in. into the bottom of the chair legs. The extra elevation makes it easier to paint and even lets you coat the bottom of the legs. This also works great with brush-on paint.



## Release masking tape with heat

If masking tape tears as you remove it or pulls off flakes of finish, heat it with a hair dryer. Heat softens the adhesive. Then pull the tape off at a 90-degree angle.

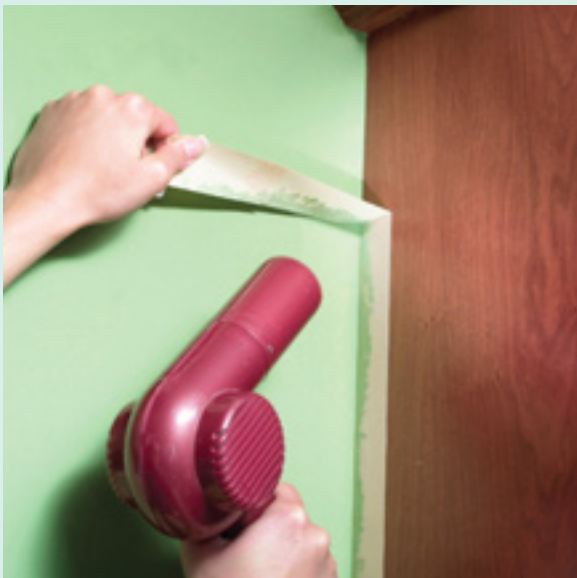

## Coat hanger drip stopper

Cut the bottom section from a stiff wire coat hanger and bend it so each end straddles the rim to fit inside a paint can. Let the wire overlap the sides and tape it to the can to keep it steady when you rub off the excess paint. When the job's finished, remove the wire and wipe it clean to be ready for next time.





## ✦ Test stains, thoroughly!

You can't rely on those stain samples on display in stores. Actual color varies a lot, depending on the type of wood and how you prepare it for finishing. So save scraps from your project, run them through the same sanding process and use them to test finishes. If you didn't build the item you're finish-

ing, run tests on an inconspicuous area—the underside of a table, for example. Test stain on scraps to get the color you want. Leaving excess stain on the wood for longer or shorter periods won't affect the color much. If it's a custom color you're after, you can mix stains of the same brand.



## Paintbrush holder

Soak oil brushes in cleaning solvent without bending the bristles and ruining the brush! Clip a medium or large

binder clip around the handle of a brush and spread the arms to span a cleaning container so the brush bristles don't touch the bottom.

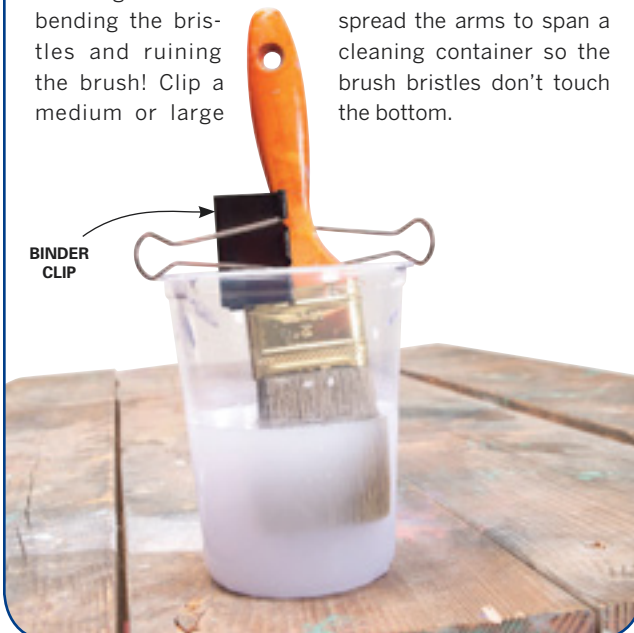

## Out-of-the-way paintbrush storage

Hang your paintbrushes out of harm's way by installing a couple of screw eyes or cup hooks on the bottom of a couple of rafters or floor joists. Then thread the brush handles through a stiff wire (or welding rod) and hang it all up.



## Filter dirty paint

You probably have a few cans of pricey paint that you're afraid to use because they contain rust, chips and lumps of hardened paint. Refresh that paint by filtering it through old nylon pantyhose. You can usually get a new empty can from a local paint store for a few bucks.



## Paint all *four* sides of spindles at once

Finishing spindles is a pain because you have to finish three sides, let them dry and then turn them over and do the unfinished side. But not if you drive long drywall screws into the spindle ends and then rest the screws on two boards or sawhorses. An added bonus is that you can keep your fingers out of the wet finish by holding onto the screws as you paint and turn.



## Stain-saving spray applicator

Save your empty pump-type sprayers that have an adjustable-spray tip and use them to apply stain. Spray a small section at a time, then wipe it. You'll be surprised how little stain you use to complete the job this way compared with brushing. This technique is especially helpful for applying stain to intricate parts like spindles.



## Special section: Instant makeovers

# Bring tired-looking windows back to life

Wood windows with a natural finish on the inside look great when they're new, but moisture, temperature swings and harsh sunlight eventually make the varnish fade and flake away, especially along the bottom of the window sash and on the sill. Usually the only part of the window that needs work is along the bottom—the rest of the sash and trim can just be lightly sanded and recoated.

The first step is to match the stain and finish. The easiest way to do this is to take a piece of the trim to a paint store to have it matched (Photo 1).

Scrape off any worn varnish (Photo 2), then sand with 120- or 150-grit sandpaper. In partially damaged areas, feather the sanding into the undamaged areas, then lightly sand the rest of the piece to prepare it for a new finish. You don't need to sand and recoat the entire window if only a few pieces need it—just stop at an edge or corner.

Stain the wood (Photo 3) and apply two coats of outdoor-grade finish. If the gloss doesn't match the older varnish, buff it lightly with extra-fine steel wool or a sanding pad to dull it.

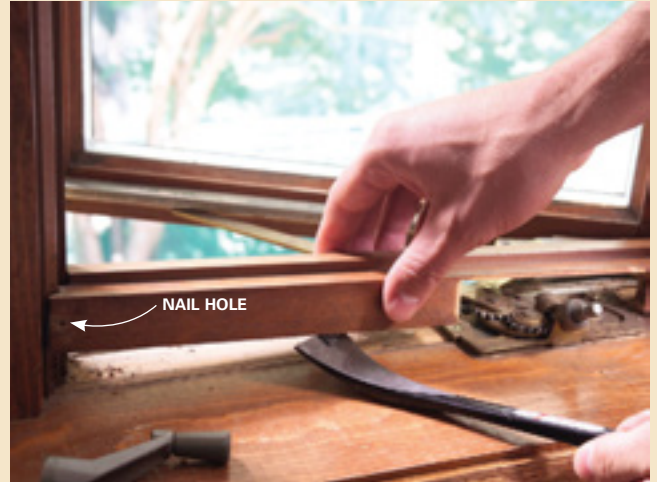

**1** Carefully remove the wood cover of the casement operator (or other piece of trim) and use it to match the stain.

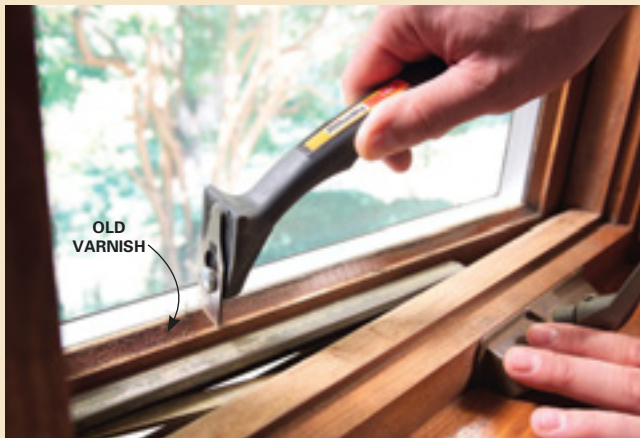

**2** Use a sharp scraper to remove old finish. Pull the scraper smoothly and carefully to avoid gouging the wood.



**3** Rub stain into the sanded sections of the window. Wipe off quickly, then apply more as needed to darken the color.

## ✦ Easy-to-install windowsills

Windows in new homes are often left without trim. Instead, the whole opening is covered in drywall, then taped and painted. It's a design trend intended to save on construction costs. The problem is that it leaves the recessed windowsills vulnerable to moisture (from condensation and potted plants) and scratches, dents and stains from objects that are set there. Sill-Rite's new vinyl windowsills protect the sill from moisture and damage while offering a stylish accent to the window. Prices start at \$14.

The maintenance-free sills are prefinished in white (they don't need to be painted, but can be if you'd like a certain color) and sized for standard window openings. Directions for measuring the sill size and detailed installation instructions are included on the company's Web site. Dealers are also listed online.

**Sill-Rite**

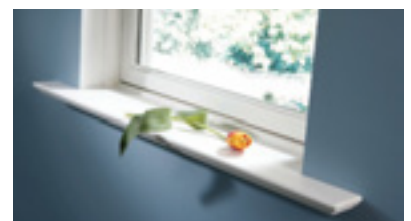

# 7 tips for floor prep

When you're about to lay a new floor, you have the perfect opportunity to upgrade your subfloor to make it solid and squeak-free. While the specifics might vary a bit depending on your new flooring material, consider these issues:

- **Deflection/stiffness.** If you find soft spots in your floor or areas that "give" as you walk across them, stiffen them by adding framing from below or more underlayment on top. Ceramic tile floors require extra stiffness to keep grout lines from cracking.
- **Bounce.** If the dinner plates rattle every time you walk across your kitchen floor, you're getting too much vibration or bounce. Corrections must be made from below.
- **Flatness.** Now's the time to level off high spots and fill low areas so your new floor runs true.

- **Squeaks.** Drive screws through the subfloor into joists to eliminate the wood movement that causes squeaks. Use adhesive as well as screws to fasten new underlayment.
- **Surface flaws.** Some flooring, like vinyl, linoleum and carpeting, requires perfectly smooth subfloors or underlayments. Otherwise, every flaw will show through in the surface.
- **Moisture in concrete.** Always check the moisture level in concrete before laying flooring over it. Trapped moisture will ruin the floor and encourage mold.
- **Asbestos.** Asbestos, a proven carcinogen, was used in many types of flooring and adhesives. While old flooring isn't hazardous if left undisturbed, don't rip it out unless you know it's asbestos-free. Call your local health department for instructions about how to collect a sample and have it tested for asbestos.

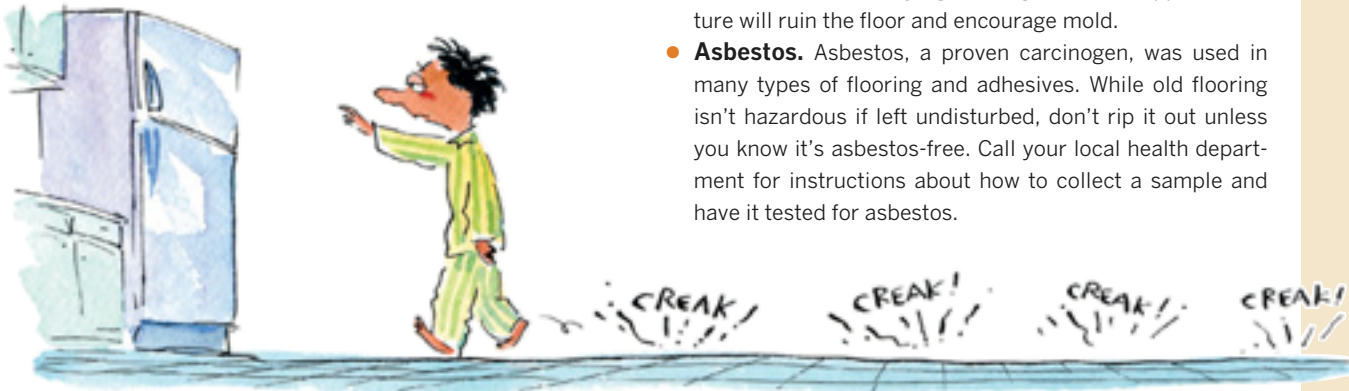
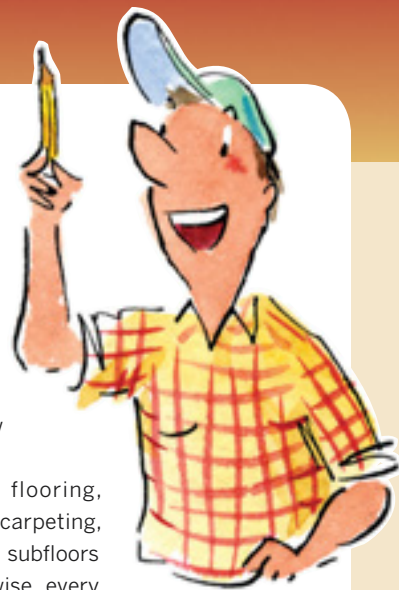

# 5 tips for adding new floors

The next time you're thinking about adding a new floor, consider these potential problems:

- Will all the appliances fit? Pay careful attention to the refrigerator if it has a cabinet directly over it with minimum clearance.
- What about the transition from one room to another? A difference of 1/2 in. to 3/4 in. is usually acceptable, but steeper transitions can look awkward and pose a tripping hazard.
- If the floor adjoins a staircase, are the stair risers still consistent? Too much buildup on the floor can make the lower or upper step height dangerously different from the rest. Most building codes mandate that no step on a staircase vary in height by more than 3/8 in. from the rest.

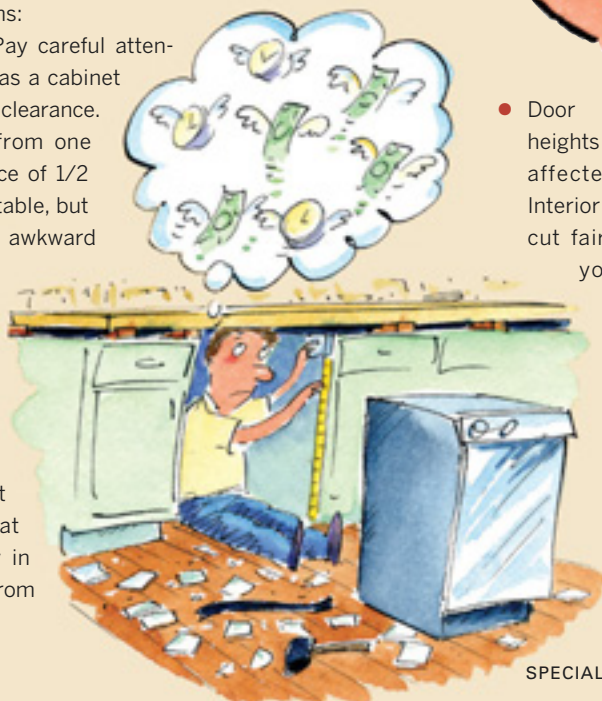

- Door heights can be affected as well. Interior doors can be cut fairly easily, but you usually can't cut off an exterior door at all, much less raise a threshold. And there may be no room for a "mud" rug under the door as it swings into the room.
- Consider the toe-kick space under the cabinets. It should be greater than 3 in. or you could get your work boots caught between the floor and the cabinet.

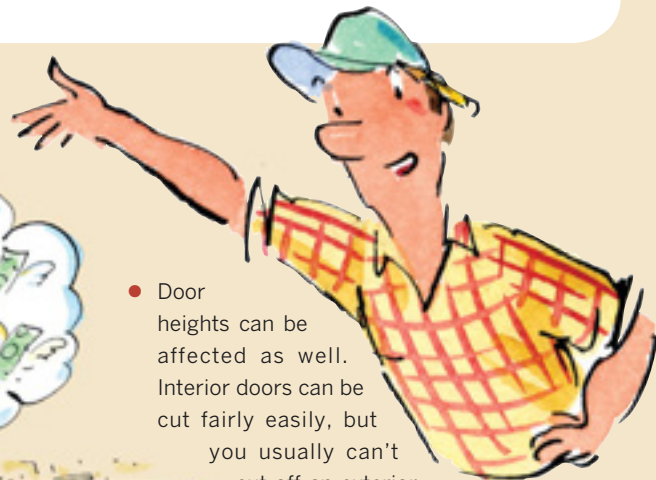

## Perfect match outlet covers

To cover and create outlet or switch plate covers that match the pattern of the surrounding wall, follow these steps: Match the pattern on a scrap piece of wallpaper with that on the surrounding wall (Photo 1). Wet or apply paste to the paper, position it and gently remove the wallpaper and plastic cover

from the wall. Next, fold the edges back around the cover and secure them with wall covering seam repair (Photo 2). Cut the corners for crisper folds. Finally, cut out and remove the excess wallpaper using the openings in the plastic cover as a guide (Photo 3).

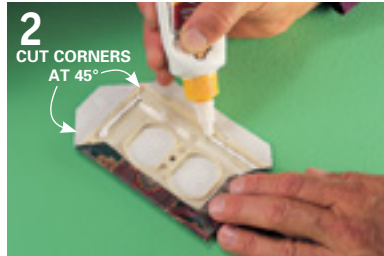

## Bubbling wallpaper

Fix bubbles in wallpaper by cutting them with a razor knife. A small slit is all that's needed. Then insert the end of a glue applicator in the slit and squeeze in a little adhesive.

Wipe away excessive adhesive with a damp sponge and press the wallpaper against the wall to force out the air, using a plastic straightedge.

The glue applicators and adhesive are available at paint stores and home centers.

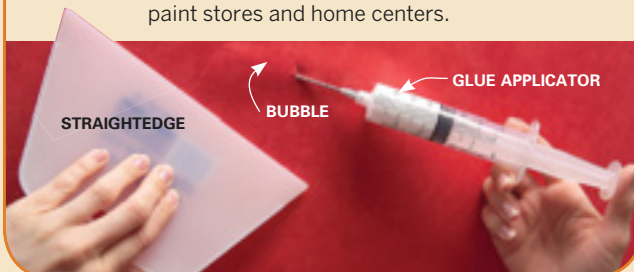

## Fix bad wallpaper seams

Repairing loose wallpaper seams is fairly simple. Just apply a seam repair adhesive. It provides a solid bond and will keep the seams from coming loose. It's available at paint stores and home centers.

Squirt the adhesive directly onto the wall behind the loose seams, then press the edges back into place. Use a roller or straightedge as shown to firmly press the paper against the wall and drive out any air bubbles. Wipe away any excess adhesive with a damp sponge.

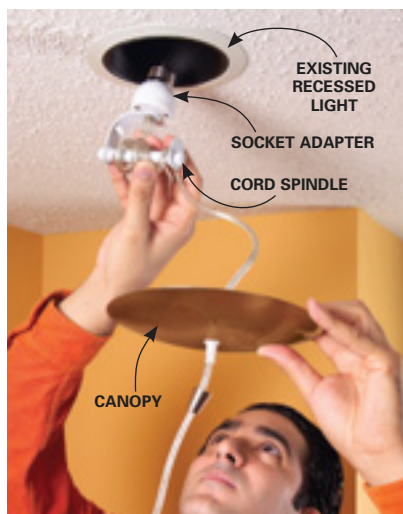
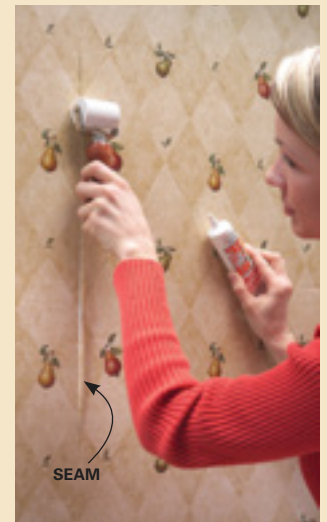

## Lighting makeover

Everyone likes fast, easy ways to beautify a room. And that's what Worth Home Products' new pendant lights do. Installation is simple: Unscrew the recessed light, adjust the length of the pendant light cord, screw the adapter in, slide the canopy up to the ceiling and you have a new light hanging overhead. A room transformation doesn't get any easier than this (if you can change a lightbulb, you can install these lights). Several styles of the Portfolio recessed light conversion kit are available at [amazon.com](http://amazon.com).

**Worth Home Products**





2

# Get organized



The 32 tips in this chapter will help you quickly and efficiently organize your home without spending a lot of money. From simple ideas for cutting the clutter in the kitchen to practical storage solutions for your closets, these tips can bring instant organization to any room in the house.



## Racks for canned goods

Use closet racks as cabinet organizers. Trim the racks to length with a hacksaw and then mount screws to the back side of the face frame to hold the racks in place. The back side of the rack simply rests against the back of the cabinet. Now you can easily find your soup and check the rest of your inventory at a glance.

## Wine glass molding

T-molding designed for wood floor transitions makes a perfect rack for stemware. Just cut it to length, predrill screw holes and screw it to the underside of a shelf.

For a neater look, use brass screws and finish washers. Prefinished T-molding is available wherever wood flooring is sold.

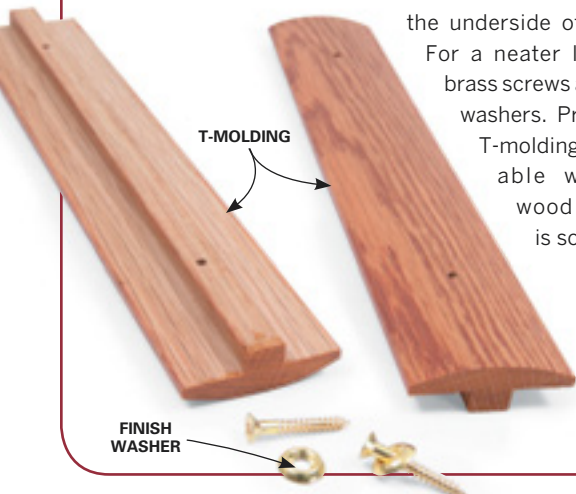

## Stop drawers from falling out

To keep a drawer in the cabinet where it belongs, drill a hole in the side of the box and make this stop with a dowel, a screw and a fender washer. It's easy to make and to remove.



## Plastic bag holder

An empty rectangular tissue box makes a convenient holder for small garbage bags, plastic grocery bags and small rags. Simply thumbtack it to the inside of a cabinet door.

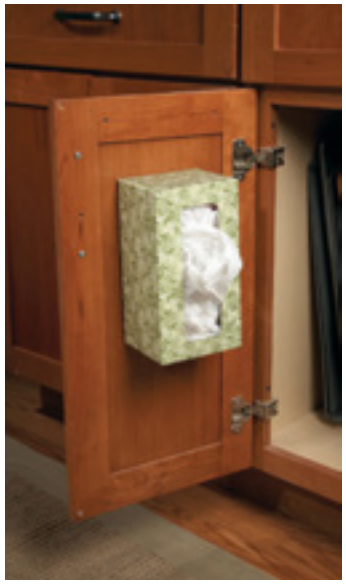

# Add a closet rod and shelf



This project will save you hours of ironing and organizing. Now you can hang up your shirts and jackets as soon as they're out of the dryer—no more wrinkled shirts at the bottom of the basket. You'll also gain an out-of-the-way upper shelf to store all sorts of odds and ends.

Just go to your local home center and get standard closet rod brackets, a closet rod and a precut 12-in.-deep melamine shelf. Also pick up some drywall anchors, or if you have concrete, some plastic anchors and a corresponding masonry bit. Follow the instructions in Photos 1 and 2.

## tip

You can get these great-looking Lido Rail chrome brackets and rod at home centers or buy them online.

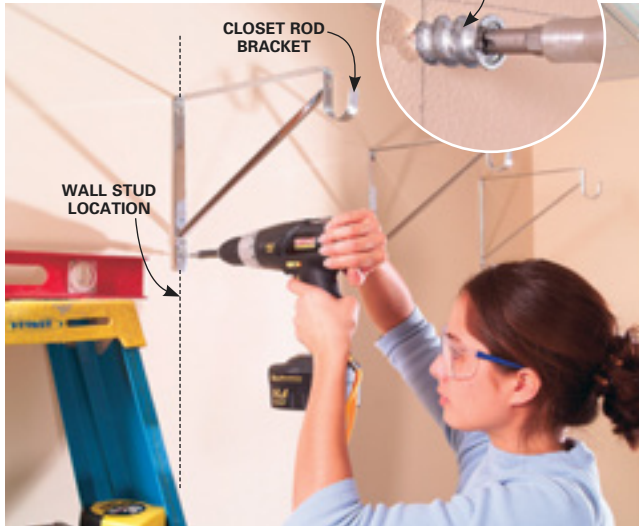

**1** Draw a level line about 78 in. above the floor and locate the studs behind the drywall. Fasten at least two of your closet rod brackets to wall studs (4 ft. apart) and then center the middle bracket with two 2-in.-long screws into wall anchors (inset).



**2** Fasten a 12-in.-deep Melamine shelf onto the tops of the brackets with 1/2-in. screws. Next, insert your closet rod, drill 1/8-in. holes into the rod, and secure it to the brackets with No. 6 x 1/2-in. sheet metal screws.

## Thyme saver

If your spices are jammed into a drawer with only the tops visible, this nifty rack that slips neatly into the drawer will solve the problem. And it only takes an hour to build. Make it with scraps of 1/4-in. and 1/2-in. plywood.

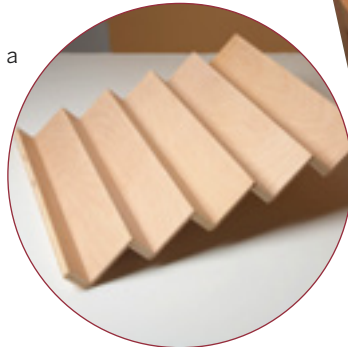



## Recycling zip ties

Whenever you buy something that's wrapped with zip ties, don't cut them off and toss them. Instead, remove the ties by inserting the tip of a pocketknife under the ratcheting mechanism of the ties and pulling the end out. You can reuse the ties and never worry about overtightening one because you can reposition it.

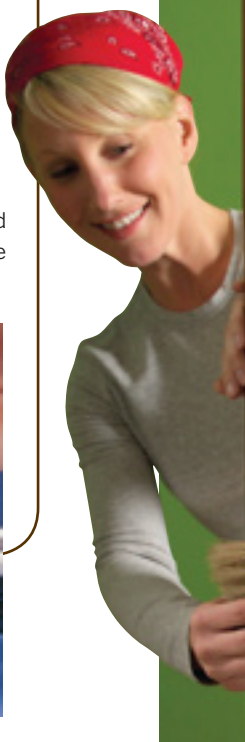
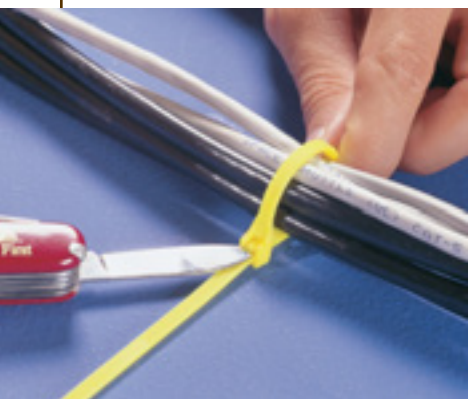

## Tool-apron storage

Tool aprons can be modified to store nearly any household item. Just sew a variety of pocket widths in the aprons, then mount the aprons by screwing a wood strip through the top of each and into a door. For hollow-core doors, use hollow anchor fasteners to hold the screws firmly to the door.



## Laundry organizer

Make laundry day easier with this shelf for all your detergents, stain removers and other supplies. Build this simple organizer from 1x10 and 1x3 boards. If you have a basement laundry room, you may need to cut an access through the shelves for your dryer exhaust.



## Car-care file in the trunk

Keep your car's maintenance records in the car and you'll never have to ransack your house looking for them. Just put them in a zip-top plastic bag and slip them under the carpet in the trunk.



## Storage pockets for skinny things

Saw off short pieces of 1-1/2-, 2- or 3-in. PVC plumbing pipe with 45-degree angles on one end. Screw them to a board to hold paintbrushes, pencils, stir sticks and just about any other narrow paraphernalia in your garage. Mount them by drilling a 1/4-in. hole in the angled end, and then drive a 1-5/8-in. drywall screw through the hole into the board.



## Baseball equipment organizer

If you have a family with one or more future big league baseball or softball players, build this bat and ball organizer to keep the equipment tidy. Build the racks as shown from PVC pipe and boards, then mount them to the wall or the back of a closet door.

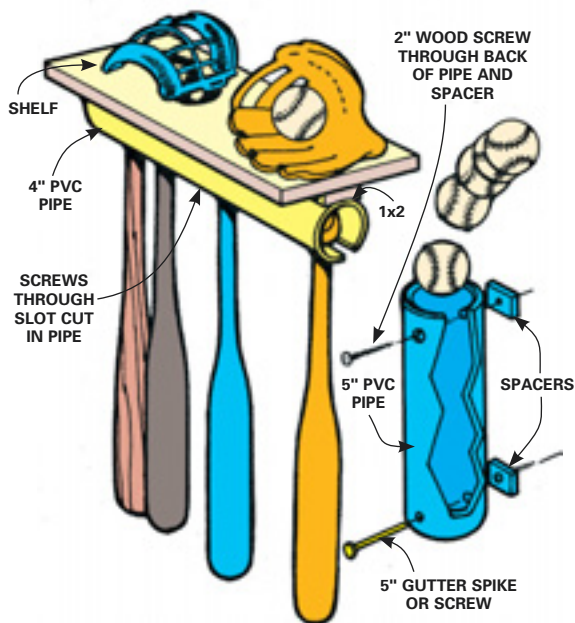

## Easy-to-build display shelves

Build this simple display shelf from 1x4s and tempered glass. Secure the short side sections to the 48-in.-long back sections using wood glue and 4d finish nails. Paint the brackets and screw them to the wall. Buy round-cornered tempered glass shelves and slide them in place.

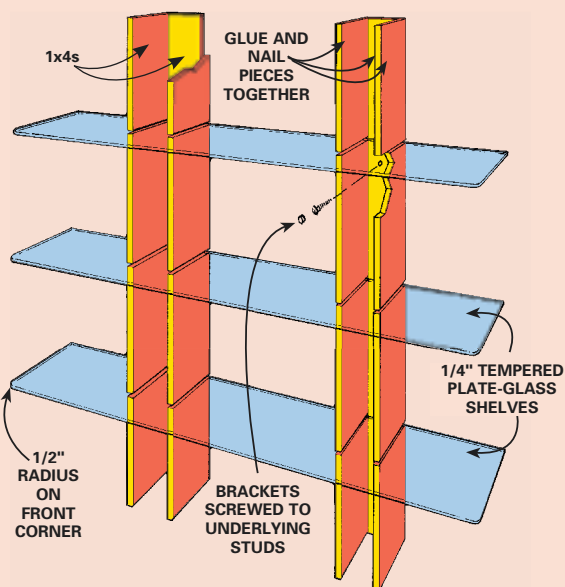

## Spice storage

Small spice containers use shelf space inefficiently and are difficult to find when surrounded by taller bottles and items. Use a small spring-tension curtain rod as a simple shelf. It's easy to install and strong enough to support the spices.



# Magazine storage bins

Finally got the time to build that project in *The Family Handyman* from three years ago? Great ... if you can find the right issue! Here's a handsome solution. Build these bins and stock them with an orderly archive, and you'll have instant access to years of projects and plans. You can build four bins from one 2 x 4-ft. sheet of 1/4-in. plywood and two 6-ft.-long 1x4s. Here's how:

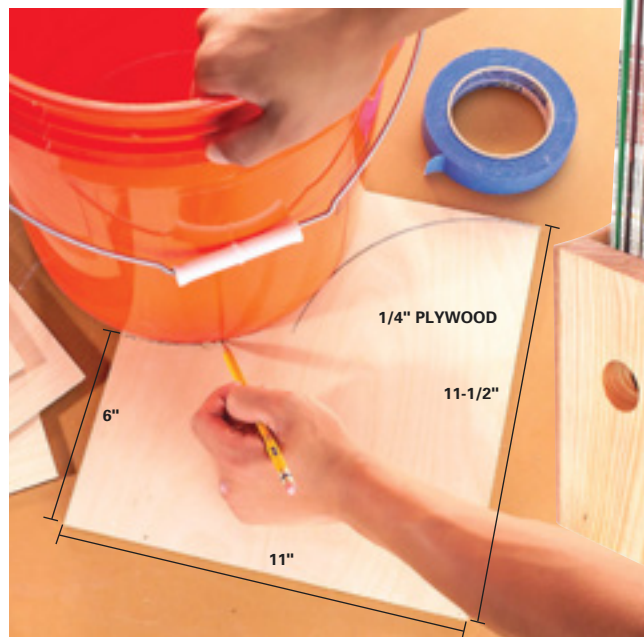

**1** Cut the 1/4-in. plywood into eight 11-1/2-in. x 11-in. pieces. Use a 5-gallon bucket to trace a graceful S-curve from the 11-1/2-in.-high corner across the plywood to a 6-in. mark on the opposite side. Simply establish a smooth curve.



**2** Stack pairs so the best sides face each other and tape all the sheets together flush at the edges. "Gang cut" the curve with a jigsaw or a band saw.

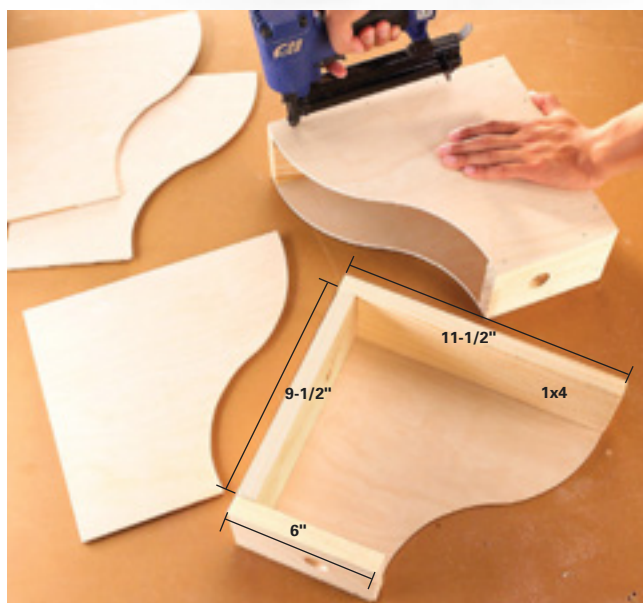
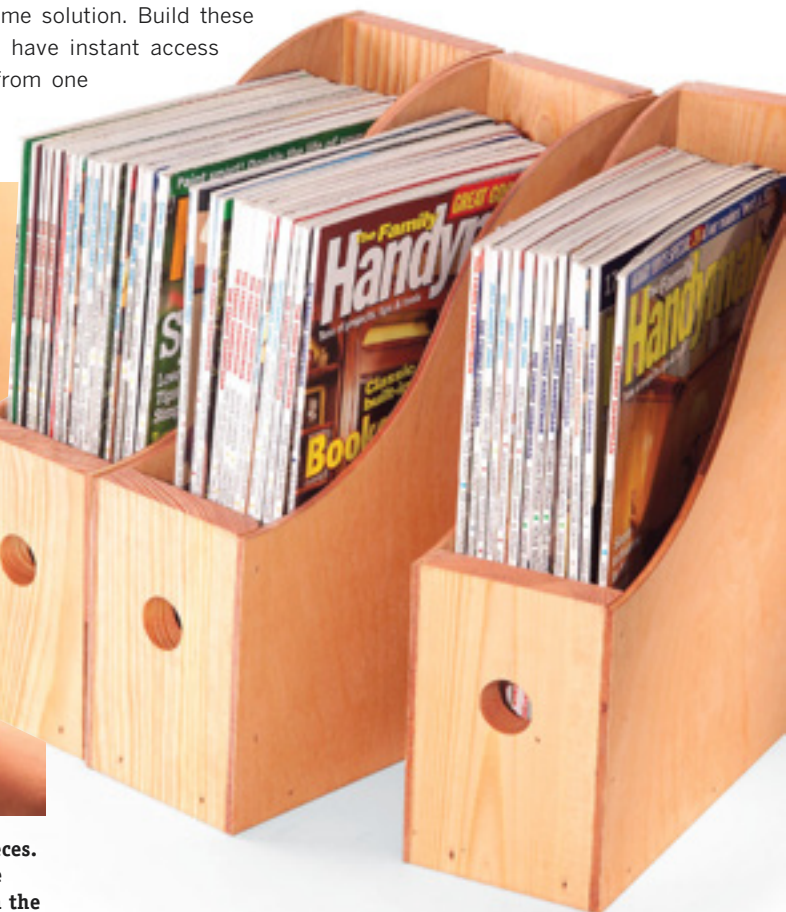

**3** Saw pine boards into 6-, 9-1/2- and 11-1/2-in. lengths. Drill 1-in.-diameter finger pulls in the 6-in. pieces, then nail the frames together. Nail the sides to the frames with 1-in. finish nails, sand as needed and apply a finish.

## Between-the-studs shelving

Store small containers—spray paint, putty cans, glue bottles—right in the wall! Screw shelf brackets (6-ft. lengths are available at home centers) to the studs, then install shelves, cut from standard 1x4 boards, on adjustable clips. The boards fit perfectly; there's no need to saw them to width.

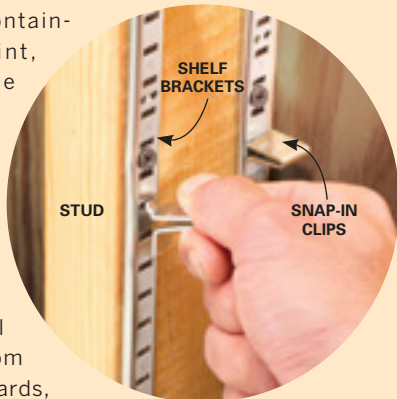

## Shoe-storage booster stool

Build this handy stool in one hour and park it in your closet. You can also use it as a step to reach the high shelf. All you need is a 4 x 4-ft. sheet of 3/4-in. plywood, wood glue and a handful of 8d finish nails. Cut the plywood pieces according to the illustration. Spread wood glue on the joints, then nail them together with 8d finish nails. First nail through the sides into the back. Then nail through the top into the sides and back. Finally, mark the location of the two shelves and nail through the sides into the shelves.

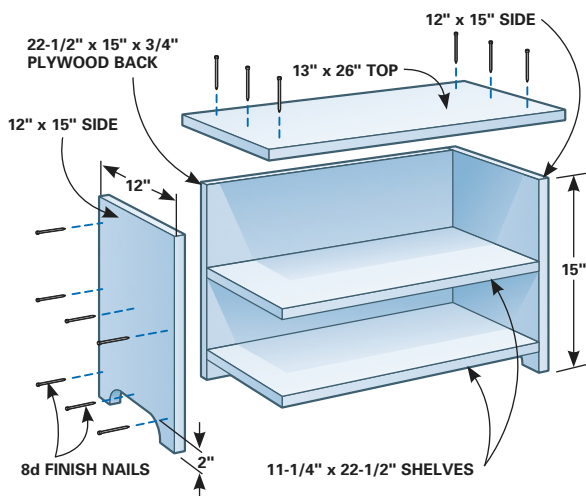

## Cookware organizer

Most kitchen base cabinets lack vertical storage space for big, flat cookware like cookie sheets and pizza pans. To provide it, just remove the lower shelf, cut a vertical panel of plywood and fasten it at the cabinet bottom with furniture braces and at the top with a strip of wood. Drill holes for the adjusting pins to match the original locations and trim the shelf to length.



## Disappearing remotes

If your remote controls are cluttering up your coffee table and getting lost behind sofa cushions, here's how to tidy up. Apply adhesive-backed hook-and-loop strips to the underside of the coffee table and to the backs of the remotes. To avoid snags on upholstery and clothing, put the soft (loop) material on the remotes. Now all the controls are hidden from view, but you'll always know where to find them. Hook-and-loop strips are available at home centers, discount and hardware stores.



## Ski and pole organizer

Keep your skis up and easy to find with this simple 2x4 rack. Drill 3/4-in.-diameter holes spaced 3/4 in. apart. Glue 4-1/2-in. lengths of 3/4-in. dowel into the holes and then mount the 2x4 to the wall studs. Space the groupings about 8 in. apart to make room for ski bindings. Now you'll spend less time looking for your skis and more time on the trails.



## Under-sink archives

Don't file away the manuals for your kitchen and bath fixtures. Instead, slip them into a zip-top plastic bag and hang the bag in the cabinet under the sink. They'll always be right where you need them. Toss in paint samples and spare cabinet hardware too.



## Medium-weight ceiling lift

Tired of shoving the stuff in your garage from one side to the other without gaining any floor space? Then try raising it to the ceiling. With the 4 x 4-ft. HeavyLift platform from Racor, you can load, lift and store up to 250 lbs.—keeping things off the floor.

A hand crank raises and lowers the platform (no ladder needed). The system can be mounted to ceilings up to 12 ft. high. It's perfect for seasonal items that you don't want to hassle with year round. Find retailers on the company's Web site or order online.

**Racor**



# Super stuff sacks

Ever try, unsuccessfully, to fit 10 lbs. of blankets into a 5-lb. bag? Now you can do it with ease. Space-saving storage bags use a vacuum cleaner to ensure that you're only storing stuff, not air.

They're ideal if you put lots of winter clothes and bedding in storage every spring. These bags can double your storage capacity. Just fill the bag with clothes or bedding, seal the top, and suck the air out using a vacuum. Seal the vacuum port and you're good to go. The bags can be reused, so come fall, you can store your summer stuff.

No matter how you put items into the bag, the vacuum suction will compress them. However, the more neatly you fill the bag, the flatter it will end up. Various sizes are available, so you can match the size to the items you're storing.

Several brands of these bags are on the market. The one shown here is a Space-maker Bag, available online (search "spacemaker bag").

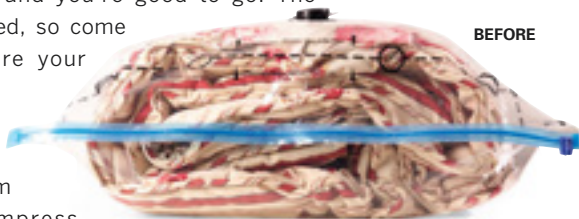

## Quick-install clothes rod

If you need a clothes rod in the laundry room and you have exposed joists, check out this simple, solid and fast way to get it. Attach 3/4 in. J-hooks (these are typically used for hanging pipe) to the joists and snap a 7/8-in. dowel in the curve.



## Get rid of your old computer for free

Old computers, monitors and other accessories contain toxic materials and must be disposed of properly, not just tossed into the trash. Local recycling programs can be expensive.

However, there are a few ways to get rid of old equipment for free (including shipping) or at minimal cost:

- Dell will recycle any brand of computer at no cost when you buy a new Dell computer. The company recycles all Dell products for free even if you're not buying a new unit.
- Apple also provides free recycling, including shipping, for any old computer when you buy a new computer from an Apple store.
- Hewlett Packard has teamed up with Staples to provide thousands of recycling dropoff locations in the U.S. HP also offers free recycling and shipping (with FedEx) of HP-branded equipment. (Get a recycling voucher online first.)
- Many computer retailers offer trade-in deals or will put you in touch with companies that buy and sell used computer equipment.
- If your computer equipment is still in good working condition, with the original software, and is less than five or six

years old, you can donate it to the National Cristina Foundation. The foundation arranges donations to non-profits and schools and will find organizations in your area that need computer equipment.

No matter how you get rid of your old computer, remember to delete all personal data first.

For more information about manufacturers' policies on recycling, contact the manufacturer or a local computer store.

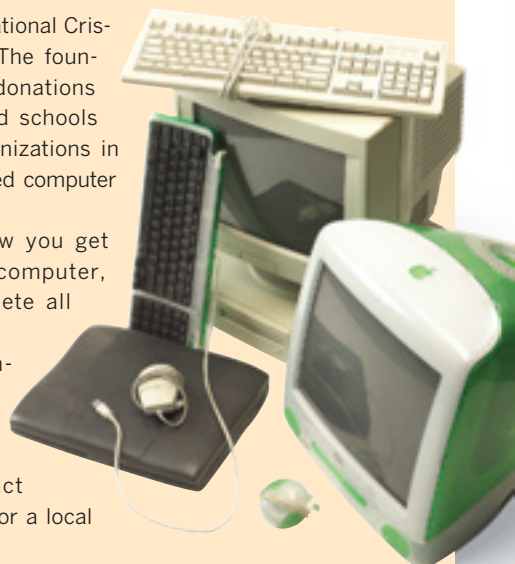

## His-and-hers shower shelves



If you need more than shampoo and a bar of soap in the shower, here's how to provide space for all your vital beauty potions: Get a couple of those shelves that are designed to hang from a shower arm and hang them on cabinet knobs. Use No. 8-32 hanger screws to screw the knobs into studs or drywall anchors.



## Double-duty shelf brackets

Shelf brackets designed to support clothes hanger rods aren't just for closets. The rod-holding hook on these brackets comes in handy in the garage and workshop too. You can bend the hook to suit long tools or cords. Closet brackets are available at home centers and hardware stores.

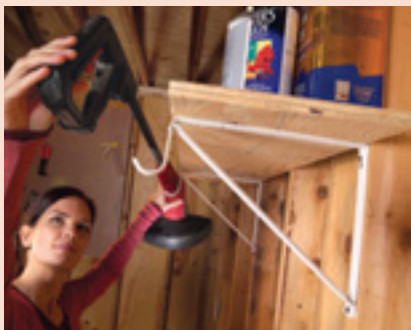

## Measuring cup hang-up

Free up drawer space by hanging measuring cups inside a kitchen cabinet. Position and mount a wood strip so that the cups will hang between the shelves and allow the door to close completely. Mount a second strip for your measuring spoons, then screw in cup hooks on both strips.

## In-a-pinch glove and cap rack

Make a simple rack for gloves and caps on the back of your closet door. Straighten a coat hanger and feed it through the middle screw-eye mounted to the door. Put as many clip clothespins on the wire as you need, then bend a loop in the wire at each end, around the outer screw-eyes.

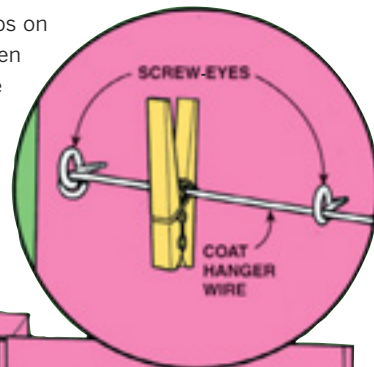

## Turn a shelf into a clothes hanger rack

Sometimes you just need another place to hang clothes, like on the shelf over your washer and dryer. Turn the edge of that shelf into a hanger rack by predrilling some 3/4-in. plastic pipe and screwing it to the edge of the shelf.



## Cutlery tray tool chest

Be honest! Somewhere you have a tool drawer bursting with a combination of screwdrivers, nail sets, tape rolls, utility knives, scissors, scrapers, measuring tapes, files and knives. And often you have to dump everything out to find one tool. Here is a solution. Fit a large cutlery tray in the drawer to organize the tools so you can see and grab the one you want in a second. The tray is easy to lift out and carry to a job, and if you use a metal mesh tray, dust can't build up between the tools.

## Organize the junk in your trunk

Does your busy lifestyle leave the back of your car looking like a jumbled mess? Jumper cables here, baseball mitts there, and groceries that tumbled over everything after you hit that bump in the road. Get some array in that disarray with a Jokari Cargo Carry All.

The Cargo Carry All has three grocery bag-size compartments, held rigid by hook-and-loop fasteners, and it folds down flat when not in use. It measures 23 x 15 x 10-1/2 in. high when open. It's available from discount stores and from the manufacturer.

**Jokari**



BEFORE



AFTER



## Special section: Fast & easy storage



### Under-joist shelf

Create extra storage space by screwing wire closet shelving to joists in your garage or basement. Wire shelving is see-through, so you can easily tell what's up there. If you want to store anything round up there, install the shelf with the hanging rod up so you are less likely to get conked on the head.

### Under-bed storage rack

If you're getting rid of your old dishwasher, hang on to the lower dish rack. Slip it under a bed for convenient roll-out storage.



### Electrical box toolholders

Junction boxes can hold a lot more than switches and wiring. Nail or screw them wherever you need handy holders for small stuff. They come in several different sizes and shapes.

# Cannery row hardware storage

Don't recycle those steel or aluminum cans quite yet. Set aside a few months' worth of fruit and soup cans and put these cannery rows to work organizing all of the small hardware in your shop.

All you need are some homemade wood clips and a chunk of 3/4-in. plywood screwed to a wall. To make the clips, rip a 3/4-in.-thick board into 1-3/8-in.-wide strips. Saw or rout a 3/8-in. x 1/4-in. rabbet along one edge.

Drill 1/8-in. screw holes every 3/4 in. and then cut off 3/4-in.-wide clips. To mount the clips and cans on the plywood, screw on a clip, notch end down, then set a can on the clip and screw on a second clip overlapping the can's rim about 1/4 in.

That's it! Keep adding clips and cans until every screw, bolt, nail and nut has a can to call home. Label the cans, and keep one loaded with surplus clips and screws for adding on.

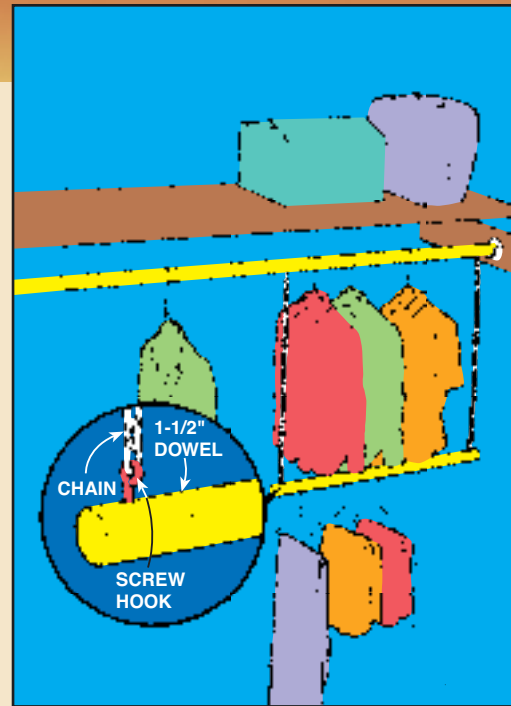
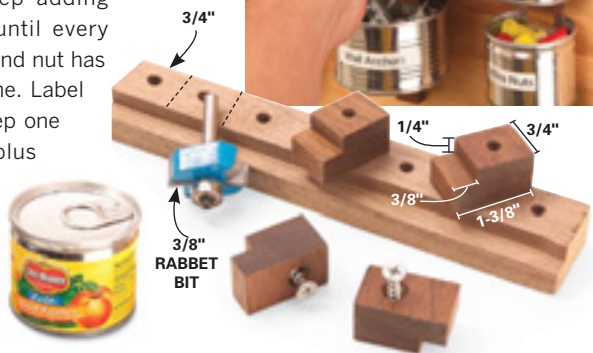

# Trapeze clothes hanger

Here's a quick way to add another clothes rod in a closet. It's especially useful in a child's closet, because you can easily adjust the height to accommodate the changing wardrobe of a growing child. Use lightweight chain attached to both the upper and lower rods with screw hooks. Squeeze the screw hooks closed with pliers.



# Overhead garage storage

Stow bulky items overhead by cementing together a simple rack from 2-in. PVC pipes and fittings. Bolt the straight pipe to the ceiling joists to support heavy loads, and screw the angled pieces from the "wye" connectors into the cross brace to stabilize the whole rack. The PVC's smooth surface makes for easy loading and unloading.



## Screw storage

If you keep screws in a coffee can, you're probably used to the screw points pricking your fingers. The can also collects dust and dirt. Instead, buy a clear water bottle with a pop-up lid and pour the screws into the bottle with a funnel. The screws stay clean, and you can shake them out of the bottle one at a time.



## Long-term storage

One way to get rid of clutter in your storage shed or garage is to do what's shown here. Screw 16-in. scrap 2x4s at a slight upward angle to each side of a wall stud. They will hold a wide variety of yard tools.



## Ladder pouch

There's no need to load up your tool belt when you're working from a ladder. Any type of hook, pouch or pocket made for a tool belt works just as well when mounted on a ladder.

## Telescoping ladder for attic storage

Werner's telescoping attic ladder, called the Televator, needs a smaller opening than conventional attic drop-down stairs, making it perfect for attic access in tight areas such as hallways and closets. Or install it between rafters in the garage (it'll fit in a 22-in. x 22-in. opening), then use the rafters for storage. The ladder is rated for 250 lbs.

The ladder quickly pulls down when you need it, then folds up out of the way when you're finished. It's available at Lowe's and amazon.com (other retailers listed online).

**Werner**



## Shoe pocket storage

Hanging shoe bags are great for closets, but they can also cut the clutter in your garage, workshop or laundry room. Shoe bags are available at discount stores.



# 3

## Money-saving tips



This chapter offers more than 70 tips for saving money. You'll find ideas for handling projects yourself instead of hiring a pro, cutting energy usage and remodeling wisely. Best of all, nearly half of these money-saving tips won't cost you a thing!

# Save money on home improvement

## Plan your project and get bids well in advance

Have you ever tried to find a contractor in March to start your new three-season porch that you want completed by Mother's Day? It'll cost more than if you'd found a contractor in January. Most contractors plan out months ahead and don't want to disrupt their schedules. They'll give you a high bid, because they really don't want to fit you in . . . unless you pay a high rate.

Most building trades have busy seasons and slow seasons. Plan ahead, and you'll get more competitive bids during the slow seasons. Best times to schedule:

- roofing—cold or rainy months
- indoor renovations—winter or during rainy months
- heating—late summer, before fall
- air conditioning—late winter or early spring
- chimney cleaning—any time except fall!
- project design (architects)—fall and winter



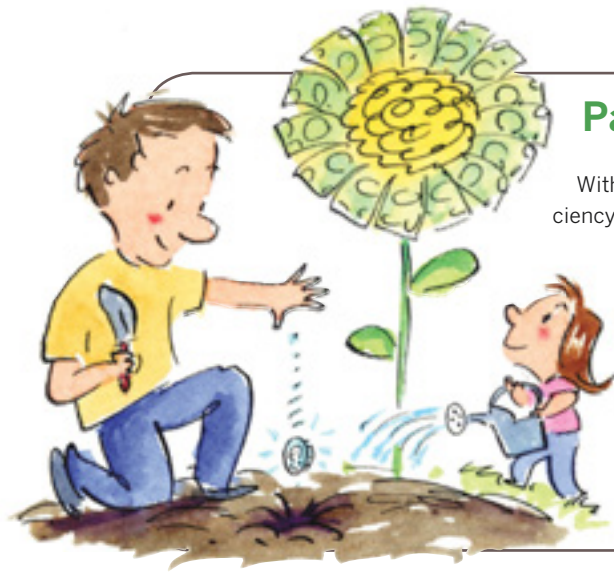

## Pay extra for energy-saving features

With energy prices rising, many contractors are offering energy-efficiency upgrades (at an additional price). These might include higher-efficiency windows; guaranteed air sealing; extra-thick insulation; and higher-efficiency heating, cooling or other appliances. If they don't offer this, you can ask what additional measures they (or you) can take to improve your home's energy performance. Then compare the estimated energy savings with the cost of each upgrade. A payback period of seven to 10 years is good. (Simple payback is the time it takes for the savings to equal the original cost.) Keep in mind that upgrades done during the remodeling process always cost less than upgrades added later.

## Hire an architect or designer for at least an initial sketch

The most expensive mistake you can make is to build an addition or remodel a room that you don't like when it's finished. Professional design help during the planning stage helps you tailor the space to fit. Sometimes it takes only one or two key details to make that room special.

Most architects and designers will walk you through the initial planning for a modest fee. Gather lots of visual material to illustrate your ideas. And be sure you're on the same page as your spouse!

Be prepared to do some legwork.

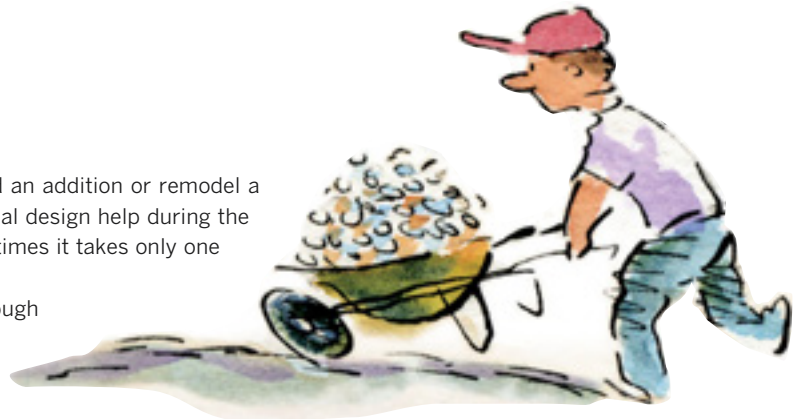

## Pitch in and do parts of the project yourself

Doing the entire project yourself is by far the best way to save money. But if you don't have the time or skills, your part-time sweat equity can reduce costs. Consider taking on such labor-intensive jobs as demolition, moving materials, digging, cleaning up the job site, sanding trim or painting. Coordinate the jobs with the contractor in advance and agree on how much money this will knock off the contractor's bill. Beware! Once you commit yourself, make sure to complete the work in a timely way. Tardiness can throw off the construction schedule and cost you more in the long run!

## Plan for future upgrades if you can't afford them now

You don't have to wait until you can build your dream addition all at once. You can get started now and gradually add as your finances allow. But work from a master plan so you don't have to go back and tear out or upgrade what you've already done.

For example, consider:

- an electrical service with capacity for the future addition, workshop or hot tub
- in-the-wall wiring for electronics in every room or a future home theater
- rough plumbing for a future half bath or hot tub
- wiring for future lighting fixtures
- rough framing for future doors or windows
- French doors that open to a future deck.

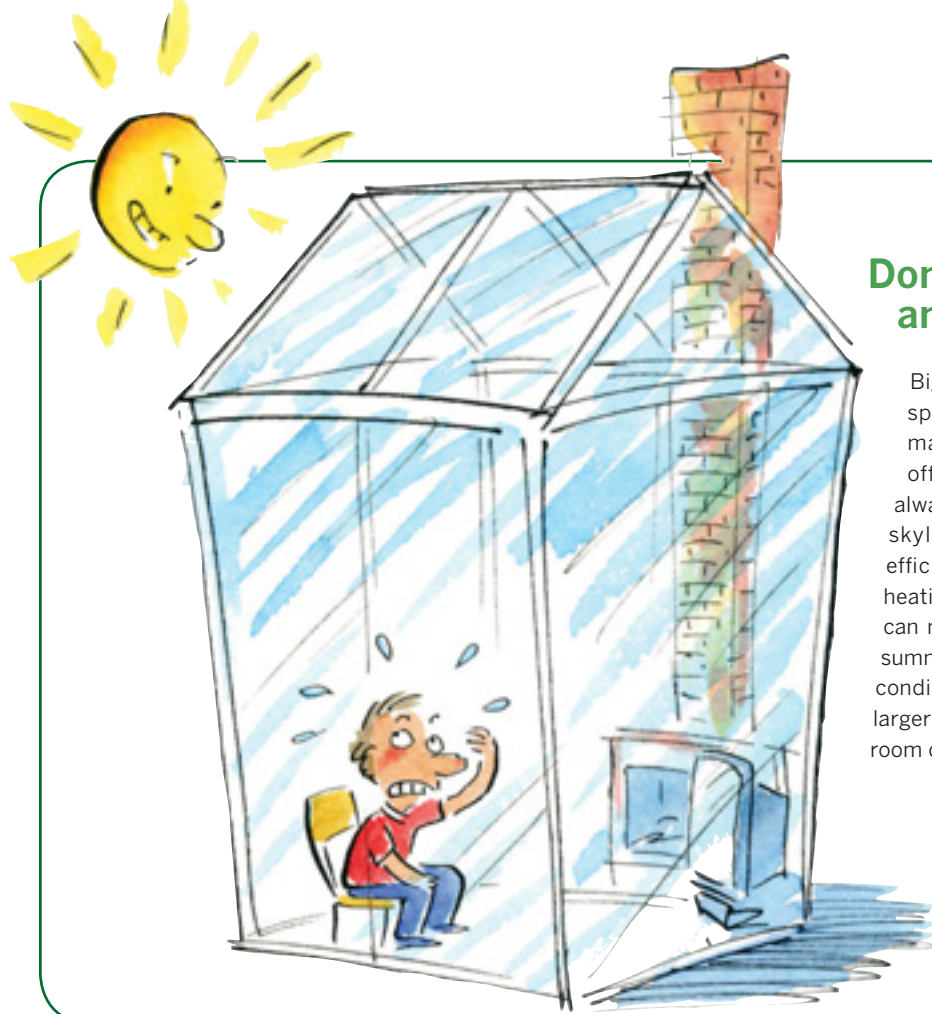

## Don't overdo windows and skylights

Big windows and skylights can have a spectacular effect in a new addition, making it feel bright and cheery and offering great views. But more is not always better. Not only are windows and skylights expensive, but even energy-efficient ones will sharply increase your heating and cooling bills. Large skylights can make a room feel like a furnace in the summer! You may have to replace your air conditioner, heat pump or furnace with a larger one. Or perhaps add units to keep the room comfortable.

## Compare the price of remodeling with the cost of buying new

Your house is your most important investment as well as the place you call home. Although you may love your house and neighborhood, check how much your addition would add to the value of your home. Creating a luxury home in a modest neighborhood may not make financial sense. A real estate agent or home appraiser can make a close estimate. If you can't recoup at least 75 percent of the

cost when you sell, at least consider the advantages of buying another house with the space or features you need. It may well be a better investment to move rather than to add on.

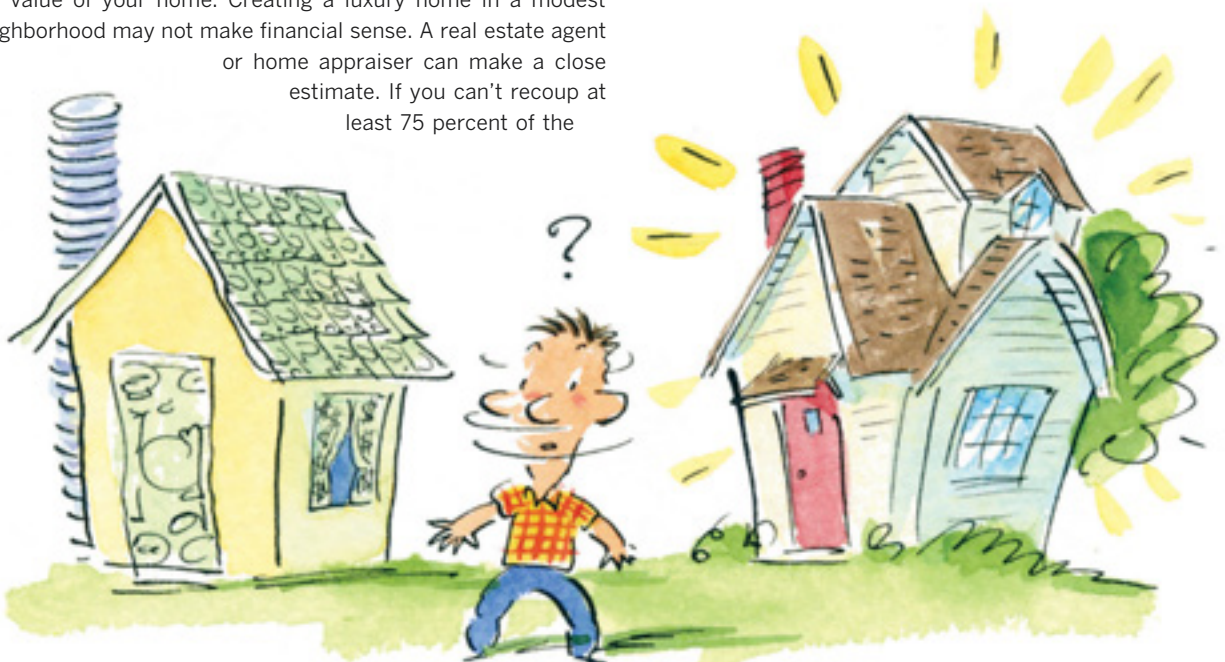

## Order online

Can't find a nice-looking low-voltage light fixture at a nearby home center? The Internet puts a wide selection of products at your fingertips. Even better, it gives you access to hard-to-find specialty items at competitive prices. Sometimes you can save 40 to 50 percent over the list price.



## Shop for materials yourself

You won't save much by trying to stockpile lumber, drywall, electrical wiring or other basic building materials. But when it comes to the finish materials—carpeting, appliances, faucets, countertops, light fixtures—your own footwork will pay off. Not only do you get exactly what you want, but you also can find bargains, especially if you start collecting these items well in advance. You can even plan to reuse a stylish old stove, distressed hardwood flooring or other items that add a creative touch to a room. But clear your decisions with your contractor; installation costs might be higher for unusual requests.



## Avoid moving the plumbing or changing the foundation

You can't always avoid it, but any alteration to these two systems typically adds thousands of dollars to a remodeling project. Neither is simple. New plumbing often requires breaking into walls and floors; resizing lines to meet newer plumbing codes; and replacing old, out-of-date pipes. New foundations

usually require excavation, concrete and other heavy, expensive work. The price jumps whenever you add these two items, so ask yourself if you really need to move the kitchen sink during a kitchen remodel, or if you really need the extra space in a bathroom bump-out.

## Save money on showering

Showers, by some estimates, consume 17 percent of the total water used in the home. And then there's the cost of heating all that water. What can you do? Well, taking shorter showers and slowing down the water flow are obvious steps. Controlling the water flow isn't a new concept, and Speakman's flow control isn't the first product to let you lessen the flow to save water. This model is a good choice because it easily threads in between the shower arm and the showerhead, and it adjusts the flow with just a flick of the switch.

The device delivers full water flow for rinsing the suds out of your hair. When you're shampooing or washing and want to conserve water, simply move the switch to change from 6 gallons per minute to 0.75 gpm.

**Speakman**







# 10 tips to save \$\$\$ on gas Y

You see gas-saving tips everywhere these days. But how much can you really save by following those tips? Actually the savings are pretty impressive. Obviously no one will have all these car problems at the same time, so your savings will be substantially less than the full \$2,000 shown here. But if you follow these tips, you will notice a difference in your fuel costs. The savings are based on driving 20,000 miles per year, in a car that gets 20 mpg, with gasoline priced at \$3.75 a gallon.

## 1 Save \$900 by keeping your tires at the right pressure

Surveys show that 50 percent of vehicles have underinflated tires. You can't "eyeball" tire pressure; you have to check it with a tire pressure gauge. It's worth your time to check tires monthly, because underinflated tires can cost you about \$750 a year in wasted gas. Improper air pressure can wear out your tires twice as fast, costing you an additional \$150 a year. The recommended air pressure for your vehicle's tires is on the decal pasted to the driver's door or pillar.



## 2 Change spark plugs before they're due

If your 100,000-mile spark plugs have 80,000 miles on them, they're 80 percent worn. Misfires and incomplete combustion occur more frequently during that last 20,000 miles, costing you almost \$562.50 in wasted fuel. You have to replace your spark plugs anyway, so do it early and pocket the savings. Even if you have to replace the plugs one extra time over the life of your car, you'll still come out way ahead.



## 3 Save \$307.50 by changing your air filter early and often

Your engine sucks 14 million gallons of air through the air filter every year. If it can't get enough air, the combustion efficiency will drop by at least 10 percent. Air filters are cheap and you can replace them yourself. Replace the filter at least every 10,000 miles or once a year, and even with that expense, still save \$270.



## 4 Save \$140 by keeping your car aligned

If your tires are bowed out of alignment by just .017 in., it's the equivalent of dragging your tire sideways for 102 miles for every 20,000 you drive. That'll cost you \$187.50 a year in wasted gas. It will wear your tires faster, as well. Here's an easy way to check your alignment without taking your car in to the shop. Buy a tread depth gauge and measure the tread depth on both edges of each tire (rear tires too). If one side of the tire is worn more than the other, your car needs to be aligned. Despite the cost of an alignment, you'll still save money the first year alone.



**Tread depth gauge, at any auto parts store**



**Uneven tread wear signals alignment problems**

## 5 Brake drag can really sink your mileage

Brake calipers have a nasty habit of rusting, binding and dragging down your gas mileage. How can you tell if your brakes are dragging without having them checked at a shop? Easy! Buy an inexpensive noncontact infrared laser thermometer, remove the wheel cover (if equipped), and aim the laser at the wheel hub after a drive. Compare the readings from the right and left sides. If they vary by more than 20 percent, you've probably got a dragging brake or a wheel bearing problem, so take it in for repairs.



**Raytek MT-4 non-contact infrared thermometer**

## 6 Replace a failing thermostat

A thermostat that opens too quickly or stays open can dramatically lower the coolant temperature and put a mega-chill on your gas mileage. Remember the infrared thermometer you bought to check your brakes? Simply aim it at the thermostat housing. If your engine is warmed up and the thermometer reads less than 160 degrees F, you're wasting gas and it's time to replace the thermostat. (To reduce reflection errors, spray the thermostat housing with black paint prior to testing.)



## 7 Lead foot = light wallet

Hard acceleration in stop-and-go driving costs you 20 percent in gas mileage. If you live your life in rush hour traffic and like to put the pedal to the metal, spend all your extra time at the next stoplight figuring out how you could have spent the \$750 a year you're wasting.



## 8 Replace a broken or missing spoiler

The plastic air dam (aka “spoiler”) that’s broken or missing wasn’t just for a sporty look. If your car had an air dam, driving without it or with a damaged one can reduce your gas mileage. The air dam literally “dams off” airflow to the undercarriage of your car, forcing the air up and over the hood. That helps your car cut through the air with less drag. It also increases airflow to the A/C condenser and radiator, reducing the load on your car’s electrical system. Contact a junkyard or visit [certifit.com](http://certifit.com) to get a replacement air dam.



## 9 Speed kills—your gas mileage and your wallet

Yes, you’ve heard it before, but how about some real-world numbers to drive the point home? Aerodynamic drag is a minor concern in city driving, but it really kills your gas mileage at speeds over 55 mph. In fact, increasing your speed to 65 increases drag by 36 percent! If you do a lot of highway driving, getting to your destination a few minutes early could cost you an extra \$637.50 a year. Keep it closer to 55 mph and use your cruise control. It will pay off.

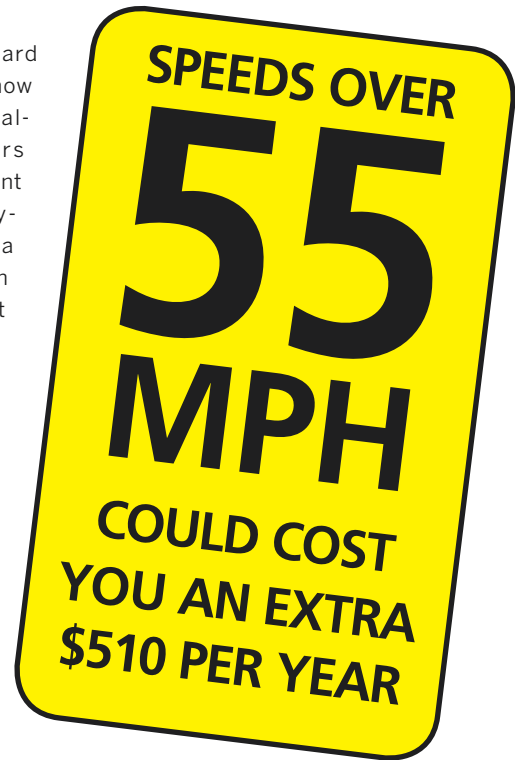

## 10 Replace your oxygen sensor(s) before the light goes on

Oxygen sensors monitor the efficiency of combustion by tracking the amount of oxygen remaining in the exhaust. But they degrade over time and that can cost you up to 15 percent in gas mileage. When they fail, the computer lights up your “service engine soon” light, forcing you to incur a diagnostic fee. On pre-1996 vehicles, replace your oxygen sensor every 60,000 miles to keep your mileage at its peak. On 1996 and newer vehicles, replace the sensors every 100,000 miles. Some vehicles have as many as four, but the sensors installed behind the catalytic converter rarely fail.



# TURN YOUR HAND TOOLS INTO POWER TOOLS



To bust loose rusted or corroded parts use the #1 selling penetrant, PB B'laster.

To keep all moving parts running smoothly use B'laster **All-Purpose** Lubricant, which outperforms the leading competitor in ASTM testing.\*

Why settle for anything less?

# "BLASTER"

[www.blastercorp.com](http://www.blastercorp.com)

THE ORIGINAL SINCE 1957



**NEW FORMULA  
OUTPERFORMS LEADING  
COMPETITOR\***

\*Based on ASTM D4172 performed by an independent laboratory. See [www.blastercorp.com/AllPurposeLubricantASTM](http://www.blastercorp.com/AllPurposeLubricantASTM) for full details.





# 10 ways to seal air leaks

**S**ealing most air leaks is surprisingly easy and will cut your energy bills. Sealing leaks also reduces drafts, making your home more comfortable, even with your thermostat at a lower temperature setting. And using that lower setting will save you more money.

Here you'll find products and techniques for sealing your house against energy loss. You can do all 10 of these projects in a single weekend—most take less than an hour and cost very little. Considering what you'll save each year in heating and air

conditioning costs, you'll see a good return on your investment. Most of the products shown here are available at home centers; the rest can be ordered online.

If you combined all of the air leaks in a typical house—up the chimney, out the dryer vent, under the front door—it would be the equivalent of leaving a window open all day long!

## 1 Check your dryer vent

If cold air comes in through your dryer vent, check outside where the vent goes through the wall. The vent should have a flap (or flaps) at the end to stop air infiltration. Make sure there's a flap and that it's not stuck open. If the flap works well, check the caulking. If it's cracking and peeling away, it's probably allowing cold air to leak in. Cut away the old caulking, make sure the vent is flush against the siding, and apply new latex caulk.

If the flap doesn't close on its own, try cleaning it and then spray silicone on the pivot point. If the flap still won't close, replace it. A new vent is available at home centers, and installing it will only take about 15 minutes.

Start by cutting away the caulking around the vent with a utility knife, remove any screws and unclamp the duct leading to the dryer. Slide the old vent out of the wall, slip in the new one and reattach it to the duct. Caulk around the vent flange.

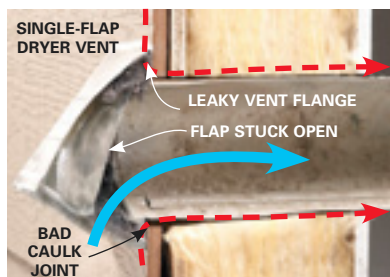

**Check that the flap (or flaps) is closed, the vent is flush against the house, and the area around the vent is properly caulked.**

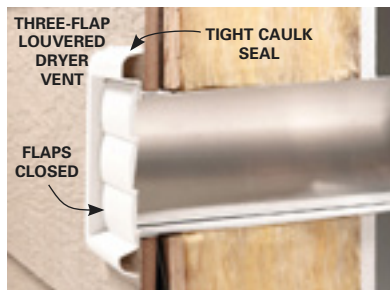

**The vent flaps are completely closed and the flange is caulked to stop air infiltration.**

## 2 Fill gaps around electrical boxes

The gaps around electrical boxes in exterior walls and ceilings are breezeways for cold air. If the gap between the electrical box and the drywall is less than 1/4 in., fill it with latex caulk. If the gap is bigger and lopsided, use foam sealant that's formulated for use around doors and window framing. The minimally expanding foam won't drip down your walls.

Turn off the power to the electrical box and use a noncontact voltage tester to ensure there's no power. Remove the cover plate. Spray the foam around the box to seal it. After it dries, cut away any protruding foam, add a foam gasket (to reduce drafts through the box) and replace the cover plate. Do the same around register openings on the inside of exterior walls.

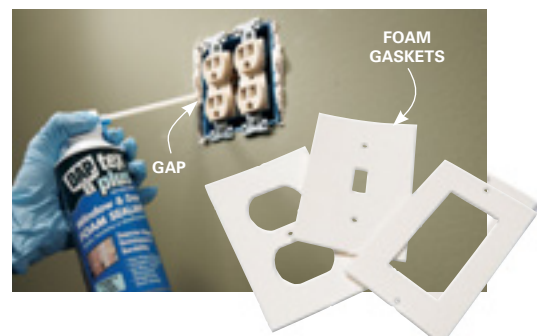

## 3 Seal leaky windows Option 1



Leaky windows are one of the biggest sources of energy loss in a typical home. If you don't want to cover your entire window, a quick, low-cost solution is to seal the gaps with removable caulk. One tube seals five 3 x 5-ft. windows.

Apply the caulk over the cracks between the movable parts of the window (sashes) and the stationary parts (jamb) and between the two sashes. Keep the bead between 3/16 and 1/2 in. wide. Don't run your finger over the bead after caulking (the caulk will be harder to remove later). In the spring, simply pull off the caulk. Clean off any residue with mineral spirits.

## 4 Seal leaky windows Option 2



If you don't like the look of caulk on your windows all winter long, cover them with plastic film instead. A kit covers five 3 x 5-ft. windows. The plastic also reduces window condensation and can be used with curtains or blinds. The film is available for the exterior and interior.

Apply double-sided tape (included) to the window casing. Cut the film roughly to size with scissors, leaving a few extra inches on each side. Starting at a top corner, apply the film firmly to the tape around all four sides of the window. Use a hair dryer to remove the wrinkles. When winter is over, take down the plastic and pull the tape off the casing. The tape removes easily without damaging the finish.

## 5 Stop under-the-door air leaks

If you can feel the breeze and see daylight under your entry door, it's costing you big-time. It also means you need to adjust your door threshold or install a new door sweep. Usually, the hardest part about replacing the sweeps is taking off the door.

Start by adjusting the threshold. Newer versions have screws that raise and lower the threshold. Turn all of the screws until the door opens and closes without much drag and any draft is eliminated. If that doesn't work, or your threshold doesn't have adjustment screws, replace the door sweep.

Close the door and pop out the hinge pins with a pin punch to remove the door.



**1** Raise or lower the threshold by turning the adjustment screws.

Set the door on a work surface and remove the old door sweep. Caulk the ends of the door, then install the replacement sweep.

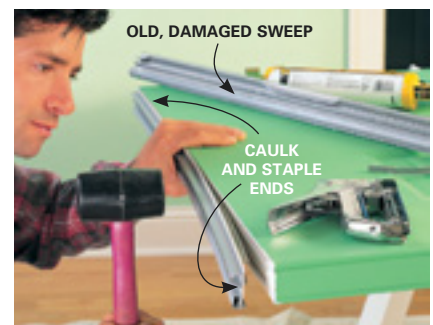

**2** Peel out the old door sweep. Tap in the replacement sweep and staple the ends with a couple of 1/2-in. staples.

Some sweeps are tapped into place and stapled along the door bottom; others are screwed to the side along the door bottom.

## 6 Caulk and cover room air conditioners

A room air conditioner keeps a section of the house cool. The problem is, it'll keep the room cool all winter long if it isn't covered properly. If you have a window unit, the best solution is to remove it so the cold air won't flow through and around it. If you decide to leave it in or you have a permanently installed wall unit, grab some removable caulk and a window air conditioner cover to keep out the cold.

Place the cover over the outside of the air conditioner, fitting the sewn-in corner straps over the bottom corners. Wrap the middle straps under and up the sides of the unit, then hook them over the top. Inside the house, apply removable caulk around the air conditioner where it meets the wall or window. If the air conditioner is a built-in unit, permanently seal it with latex caulk.



## 7 Fill gaps under sinks

Pull back the escutcheons on plumbing pipes where they enter exterior walls and you'll probably see generous gaps around the pipes. In cold weather, you might also feel the draft coming in. All it takes is some expanding foam to seal those leaks.

Shake the can vigorously, then squirt the foam around the pipes inside the wall. Don't completely fill the gap—the foam will expand. If it expands too much and you can't get the escutcheon back on, wait for it to dry, then slice it flush with the wall with a utility knife.



## 8 Finding air leaks

Locating air leaks can be tricky. They're often so small as to be hardly noticeable. To find them, follow a trail of smoke.

Close all the windows in the house, turn off all the fans and exhaust fans, and shut off the furnace. Light some incense and walk slowly around the outer walls of the house. Anywhere you notice the smoke blowing away from something or being sucked toward something, there's probably an air leak. Now that you've found it, seal it!

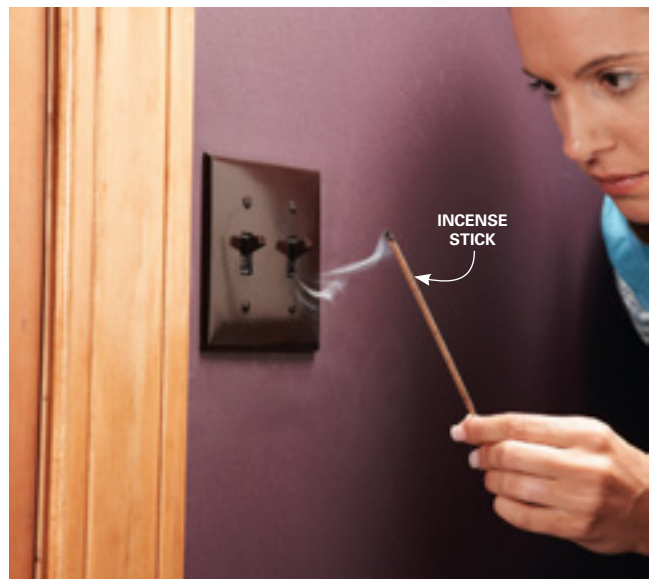

# 9 Stop airflow up the chimney



Fireplace chimneys can be very inefficient, letting your warm inside air disappear like smoke up a chimney. If you have airtight glass doors that seal the opening, you're in good shape. (The doors are available at fireplace retailers and home centers.) If not, a special balloon or chimney-top damper will get the job done.

For fireplace chimneys that are seldom or never used, inflate a Chimney Balloon inside the chimney to stop the air leaks. Partially inflate the balloon by mouth or

with a pump, then stick it into the chimney and blow it up the rest of the way. Search online for "chimney balloon" to find distributors.

Putting in and taking out the reusable balloon can be messy, so you don't want to hassle with chimney balloons if you regularly use your fireplace. But that doesn't mean you have to settle for energy loss. Instead, you can install a chimney-top damper system, like the Chim-a-lator, which seals the top of the flue when the chimney's not in use. A lever in the fireplace controls the damper via a long cable. Search online for "chim-a-lator" to find distributors.

Installation involves attaching the damper and screened-in cap to the chimney top, then mounting the lever in the fireplace. If you don't feel comfortable working on the roof, hire a chimney sweep or a mason, who can install the system.

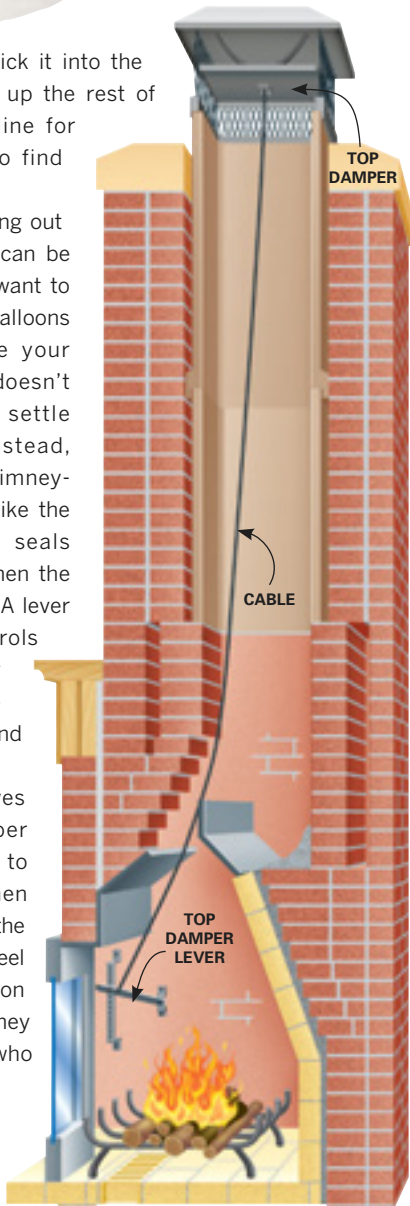

# 10 Seal small attic holes with foam and caulk

Hot air rises, so leaks in the ceiling are even worse than leaks in walls. And in many homes, this airflow through ceilings and into the attic is the No. 1 source of heat loss. You can check for leaks around ceiling light fixtures and the attic access door using an incense stick. But the only way to detect other leaks is to crawl up into the attic, pull back the insulation and look for them. Most leaks occur where chimneys and electrical and plumbing lines pass through the ceiling. Although the attic is a nasty place to work, plugging these leaks is a simple project—mostly caulking and foaming gaps.

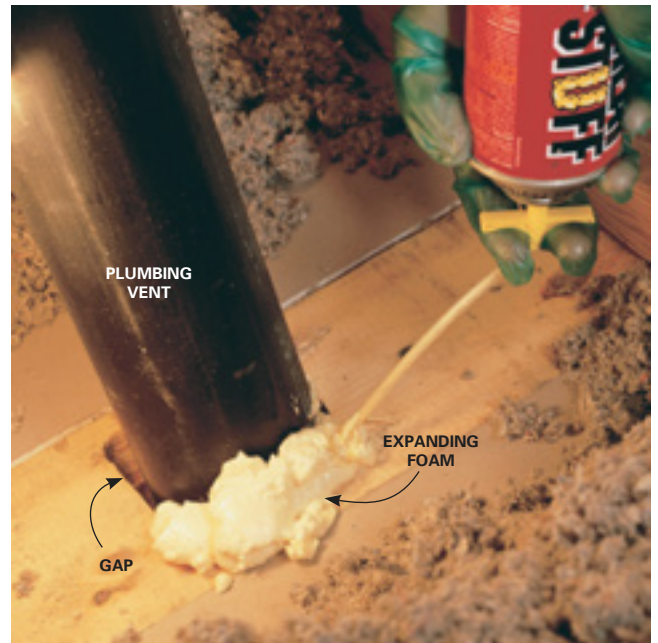



# 8 quick furnace fixes you can do yourself

## Look for simple solutions first

A furnace can be intimidating—especially when it's not working. However, there is good news from furnace repair pros. Roughly a quarter of all service calls could be avoided with easy fixes that cost little or nothing.

Here you'll learn common culprits and what to do about them.

### Caution:

Always turn off the shutoff switch (see No. 2 on p. 49) and turn the thermostat off or all the way down before changing the filter or working on the thermostat or furnace.

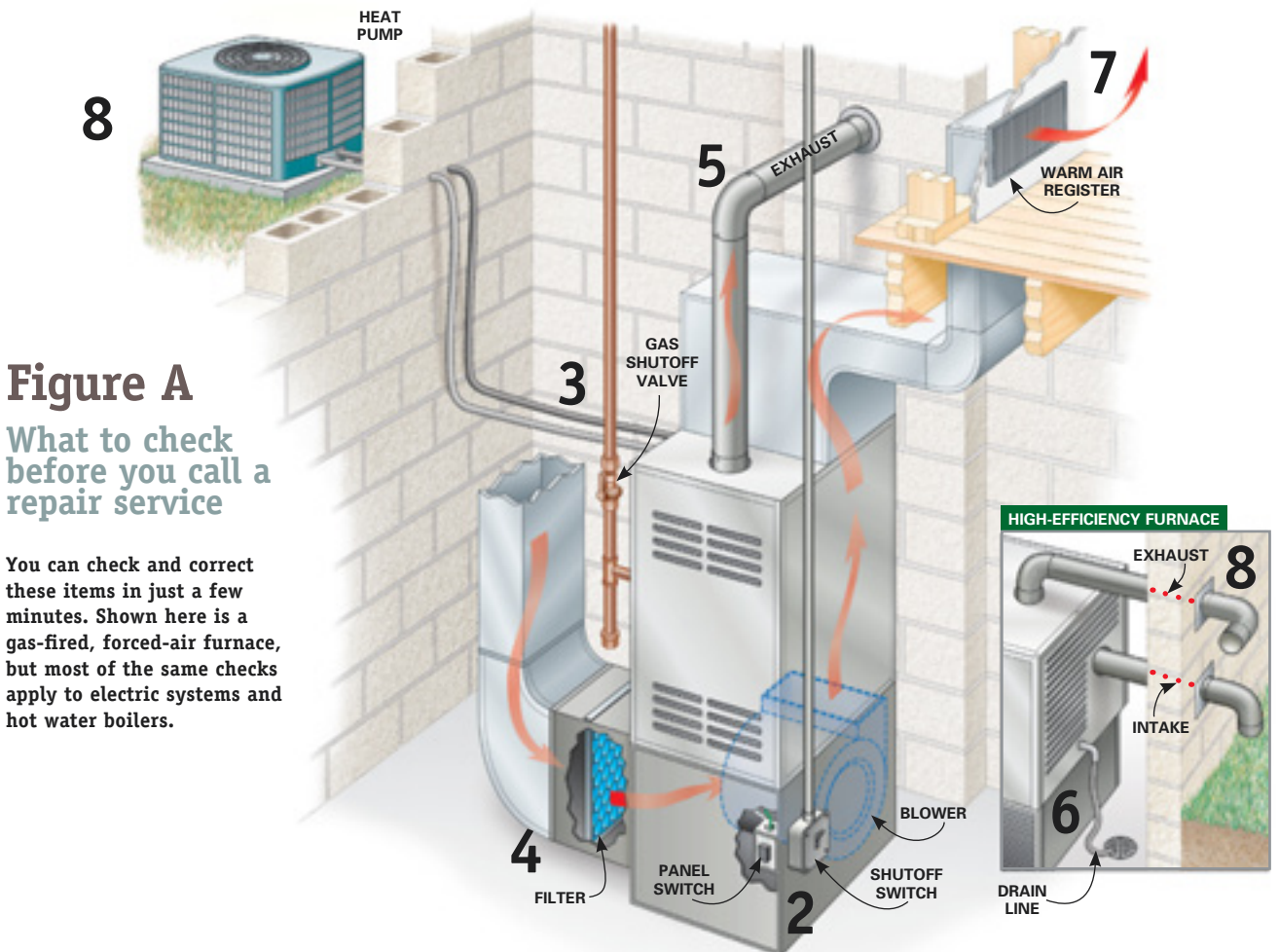

## Figure A

### What to check before you call a repair service

You can check and correct these items in just a few minutes. Shown here is a gas-fired, forced-air furnace, but most of the same checks apply to electric systems and hot water boilers.

# 1 Check the thermostat to make sure it's on

Before you assume you have a furnace problem, check the thermostat to make sure it's actually telling the furnace to come on. Thermostats, especially programmable ones, can be complicated, and the more options a thermostat has, the more that can go wrong.

- Make sure the switch is on "Heat" rather than on "Cool."
- Check the temperature setting.
- Compare the temperature setting to the room temperature. Set the temperature five degrees higher than the room temperature and see if the furnace kicks on.
- Make sure the program is displaying the right day and time, as well as a.m. and p.m. settings.
- Trace the thermostat wires back to the furnace to check for breaks, especially if you've done any remodeling recently. If you find a break in one of the thin wires,

## tip

Lost your owner's manual? Most major-brand manuals are online—just go to the manufacturer's site.



splice the line back together and wrap it with electrical tape.

- Replace the battery. If you have a power outage with a dead battery, you'll lose your settings and the thermostat will revert to the default program.
- Open the thermostat and gently blow out any dust or debris. Make sure it's level and firmly attached on the wall, and that none of the wires coming into it are loose.
- If you can't make the program settings work, you can bypass them altogether. Simply punch in the temperature you

want with the up/down control and then press the hold button. That will switch on the furnace if the thermostat programming is the problem.

# 2 Check shutoff switches and breakers

It sounds unbelievable, but furnace technicians often find that the only "repair" a furnace needs is to be turned on. Look for a standard wall switch on or near the furnace—all furnaces, no matter what age or type, have one somewhere. Check the circuit breaker or fuse for the furnace as well. Make sure the front panel covering the blower motor is securely fastened—there's a push-in switch under it that must be fully depressed for the furnace to operate.

# 3 Make sure the gas is on

Just as with switches, someone may have turned off a gas valve and then forgotten to turn it back on. Trace the gas line back from the furnace to the meter, and if you see a handle that's perpendicular to the gas pipe, turn it so it's parallel.

If you have an old furnace or boiler, you may have a pilot light. Remove the front panel and the burner cover and check to make sure it's lit.

# 4 Change filters

Dirty filters are the most common cause of furnace problems. Dust and dirt restrict airflow—and if the filter gets too clogged, the heat exchanger will overheat and shut off too quickly, and your house won't warm up. If the blower is running but no heat is coming out, replace the filter. A dirty filter also causes soot buildup on the heat exchanger, reducing the efficiency of the furnace and shortening its life.

The owner's manual shows where the filter is and how to remove it. Change inexpensive flat filters at least once a month. Make sure that the arrow points toward the furnace. Inspect pleated filters once a month. Hold them up to the light and if you can't see the light clearly through them, replace them. Manufacturers say pleated filters are good for three months, but change them more frequently if you have pets, kids or generate lots of dust.

NEW FURNACE FILTERS



## 5 Make sure the chimney exhaust flue is clear

Drawn by the warmth, birds sometimes fall into the chimney exhaust flue. Turn the furnace off and the thermostat all the way down, then dismantle the duct where it exits the furnace and check for debris. Be sure to reassemble the sections in the same order and direction that you took them out.

## 7 Look for blocked or leaky ducts that can restrict airflow

If your furnace comes on but one or two rooms are cold, first make sure all the room registers are open. Then examine any ductwork you can get access to and look for gaps between sections or branching points. Seal any gaps between sections of duct with special metal duct tape. Don't use standard cloth duct tape—it quickly deteriorates, and it may also cause ducts to leak if it was used to seal sections in the past.

Also check for handles protruding from the ductwork. These are dampers or air conditioner bypasses—make sure they're open.

## 6 Flush out drain lines

High-efficiency furnaces can drain off several gallons of water a day in heating season. If the drain lines become restricted by sediment or mold growth, the furnace will shut down. If the drain hose looks dirty, remove the hose, fill it with a mixture of bleach and water (25 percent bleach), then flush it after several minutes.

## 8 Clean away leaves and debris from heat pumps or intake and exhaust vents

If you have a furnace that vents out the side of the house, make sure nothing is blocking the intake or exhaust. If either of the pipes is covered with screen mesh (like window screen), replace it with 1/2-in.-mesh hardware cloth. If ice is clogging one of the pipes, you have a bigger problem somewhere in the system. Clear it off and call a technician to find out why it's happening.

If you have a heat pump, clear away grass and leaves from the fins of the outdoor compressor unit. Before heating season starts, hose it down gently from the top to rinse dirt and debris out of the housing.

## Apply heat-reducing window film

A heat control window film will help keep a room cooler and you can install it yourself. These films reflect the sun's heat and ultraviolet rays, and reduce glare without obscuring the view. The more direct sunlight coming through the window, the more the film will help (and it may lower your air conditioning bills!).

Applying the film takes approximately 30 minutes per window. It should last about 10 years. A 3-ft. x 15-ft. film will cover two to three windows. The film is sold at home centers and hardware stores. Gila is one company that makes heat control film.

Different types of film are available, so get the one designed for heat control. The film can be applied to any window, including double-pane low-e windows, although they already reduce radiant heat loss and gain.

One drawback is that the film may void the manufacturer's warranty for the seal on double-pane windows, although the film shouldn't affect the seal.



Window film can be installed in about 30 minutes. The hazy appearance will disappear after 10 days.



Heat control film is composed of treated micro-thin layers of film that block ultraviolet rays and reduce the summer heat that comes through the window.



# Grizzly Industrial

PURVEYORS OF FINE MACHINERY® SINCE 1983!

- OVER A MILLION SQUARE FEET PACKED TO THE RAFTERS WITH MACHINERY & TOOLS
- 2 OVERSEAS QUALITY CONTROL OFFICES STAFFED WITH QUALIFIED GRIZZLY ENGINEERS
- HUGE PARTS FACILITY WITH OVER 1 MILLION PARTS IN STOCK AT ALL TIMES
- 24 HOUR ORDERING BY PHONE OR ONLINE • MOST ORDERS SHIP THE SAME DAY

**CHRISTMAS SALE** **OCTOBER 26<sup>TH</sup> THROUGH DECEMBER 31<sup>ST</sup>**

## 6" BENCHTOP JOINTER with BUILT-IN DUST COLLECTION

- Motor: 1½ HP, 110V, single-phase, 12A
- Precision ground cast iron table
- Maximum depth of cut: ¼"
- Table size: 28½" x 6¼"
- Fence size: 22½" x 4¾"
- Cutterhead knives: 2
- Cutterhead speed: 10,000 RPM
- Cuts per minute: 20,000
- Infeed table adjustment knob
- ±45° and 90° fence stops
- Approx. shipping weight: 80 lbs.



FREE PAIR OF SAFETY PUSH BLOCKS!

**G0725** ~~\$245<sup>00</sup>~~ **SALE \$209<sup>95</sup>**



## 10" X 18" VARIABLE-SPEED WOOD LATHE

- Motor: ½ HP, 110V, single-phase, 6A • Swing over bed: 9¾"
- Swing over tool rest base: 7¼"
- Distance between centers: 16¾"
- Tool rest width: 5¾"
- Spindle size: 1" x 8 TPI RH
- Spindle speed: Variable, 650 – 3800 RPM
- Spindle and tailstock taper: MT#2
- Overall dimensions: 37¼" L x 12" D x 15" H
- Approx. shipping weight: 79 lbs.



**T25926** ~~\$279<sup>00</sup>~~ **SALE \$238<sup>95</sup>**



## 12½" BENCHTOP PLANER with DUST COLLECTION

- Motor: 2 HP, 120V, single-phase, 15A
- Max. cutting width: 12½"
- Max. cutting height: 4½"
- Max. cutting depth: ½"
- Feed rate: 26 FPM
- Cutterhead: 2 reversible HSS
- Knife size: 12½" x ½" x ¼"
- Cutterhead speed: 8750 RPM
- Number of cuts per inch: 60
- Approx. shipping weight: 72 lbs.



**G0790** **ONLY \$285<sup>00</sup>**



## 2 HP PORTABLE DUST COLLECTOR

- Motor: 2 HP, 240V, single-phase • Amps, 9A
- Air suction capacity: 1360 CFM • Static pressure: 11.3"
- Filter rating: 2.5 micron
- 6" Inlet and "Y" adapter with two 4" openings
- Impeller: 12¾" cast aluminum
- Portable base size: 27½" x 47½"
- Upper bag size (dia. x depth): 19½" x 47½"
- Lower bag size (dia. x depth): 19½" x 33"
- Lower bag capacity: 5.7 cubic feet
- Powder-coated finish
- Height with bags inflated: 94½"
- Approx. shipping weight: 137 lbs.



**G0786** **ONLY \$375<sup>00</sup>**



## 6" JOINTER with MOBILE BASE

- Motor: 1 HP, 110V, single-phase, 14A
- Max. stock width: 6"
- Max. depth of cut: ¼"
- Max. rabbeting capacity: ½"
- Cutterhead diameter: 2½"
- Cutterhead: 3 HSS
- Knife size: 6½" x ¾" x ¼"
- Table size: 7½" x 46"
- Table height from floor: 33¾"
- Fence size: 4½" high x 29¾" long
- ±45° and 90° fence stops
- Approx. shipping weight: 236 lbs.



**G0654** ~~\$455<sup>00</sup>~~ **SALE \$425<sup>00</sup>**



## 14" ANNIVERSARY BANDSAW

- Motor: 1 HP, 110V/220V, single-phase, TEFC, 11A/5.5A
- Precision-ground cast iron table size: 14" sq.
- Table tilt: 45° R, 10° L
• Cutting capacity/throat: 13½"
- Max. cutting height: 6"
- Blade size: 92½" – 93½" L (1½" – 3¼" W)
- Blade speeds: 1800 & 3100 FPM
- Approx. shipping weight: 247 lbs.



**G0555LANV** **ONLY \$545<sup>00</sup>**

INCLUDES QUICK RELEASE BLADE TENSION LEVER **FREE SHIPPING!** to lower 48 states

## 10" CONTRACTOR-STYLE TABLE SAW with RIVING KNIFE

- Motor: 1.5 HP, 110V/220V, single-phase, prewired to 110V, 11.5A/5.7A
- Precision-ground cast iron table with wings
- Table size: 25¼" x 40"
- Arbor: 5/8" • Arbor speed: 4000 RPM
- Capacity: 3½" @ 90°, 2¼" @ 45°
- Rip capacity: 30" R, 12" L
- Approx. shipping weight: 208 lbs.

FREE 10" CARBIDE-TIPPED BLADE



**G0732** ~~\$795<sup>00</sup>~~ **SALE \$650<sup>00</sup>**



## 10" HYBRID TABLE SAW with RIVING KNIFE

- Motor: 2 HP, 120V/240V, single-phase, prewired to 120V
- Amps: 15A at 120V, 7.5A at 240V
- Precision-ground cast iron table with wings measures: 40½" W x 27" D
- Table height: 35¾"
- Footprint: 21" L x 19½" W
- Arbor: ¾" • Arbor speed: 3450 RPM
- Capacity: 3¼" @ 90°, 2¼" @ 45°
- Rip capacity: 30" right, 15" left
- Overall size: 57¼" W x 35¾" H x 37½" D
- Approx. shipping weight: 348 lbs.



CAST IRON TRUNNIONS

FREE 10" CARBIDE-TIPPED BLADE

**G0771** ~~\$795<sup>00</sup>~~ **INTRODUCTORY PRICE \$675<sup>00</sup>**



**PRICING CODE**  
**15FAM5IP**  
MENTION THIS CODE WHEN PLACING YOUR ORDER

**1-800-523-4777** [grizzly.com](http://grizzly.com)

VIEW VIDEOS AT [grizzly.com](http://grizzly.com)

TECHNICAL SERVICE: 570-546-9663 • FAX: 800-438-5901

2 GREAT SHOWROOMS!

BELLINGHAM, WA • SPRINGFIELD, MO

FOLLOW US:



# 21 money- and energy-saving ideas that don't cost a dime

- 1** Lower the indoor temperature a few degrees in winter (you'll save about 2 percent per degree). Set it even lower at night and a full 10 degrees lower when you're on vacation.
- 2** Close the fireplace damper when the fireplace isn't in use. If it's never used, seal the flue with a plastic bag stuffed with insulation.
- 3** Open shades and blinds to let in sunlight during the day and close them to reduce heat loss at night. For cooling, close them during the day.
- 4** Close off unused rooms and lower the temperatures by adjusting the registers and dampers.
- 5** Clean your furnace's blower fan with a soft brush and vacuum cleaner.
- 6** Turn off lights not in use. Reduce bulb wattage and use dimmers when you can.
- 7** Ventilate and cool your home with window or whole-house fans during the cooler hours of the day.
- 8** Fill clothes washers and dishwashers for more efficient energy use, rather than cleaning partial loads.
- 9** Skip the dishwasher's drying cycle (and cut the energy use by about half!).
- 10** Wash clothes in cool rather than hot water.
- 11** Clean clothes washer and dryer lint screens after every use.
- 12** Clean refrigerator coils with a soft brush annually, or more often if you have pets that shed.
- 13** Run major appliances late in the evening or early in the morning when electric loads are less (off peak).
- 14** Flush your garbage disposer with cold water rather than hot. Grease solidifies in cold water and will wash away.
- 15** Cook more efficiently using microwaves, slow-cookers and pressure cookers.
- 16** Turn off room air conditioners when you leave for an hour or more. You can quickly cool the room later.
- 17** Recycle. Reuse. Take your bike instead of your car.
- 18** In warm weather, set the thermostat higher (75 to 78 degrees F) and rely more on ceiling and table fans for cooling, even when the air conditioner is running.
- 19** Reduce humidity in bathrooms and kitchens with exhaust fans. When dehumidifying a basement, keep basement doors and windows closed.
- 20** Consider higher-efficiency appliances when purchasing new refrigerators, freezers and dishwashers. The energy savings usually pays back the extra costs within a few years. The same goes for furnaces and water heaters.
- 21** Lower your water heater setting to 120 degrees F for both energy savings and safety. (Measure hot water temperature at a faucet with a cooking thermometer if the water heater setting isn't calibrated in degrees.)



## Replace your weather strip

Most modern prehung exterior doors have an adjustable threshold and flexible weather strip along the bottom of the door that provide a tight seal. But older wood doors usually rely on a non-adjustable threshold to keep the weather out and often lack any bottom seal. If your old wooden door doesn't seal tight against the threshold, you're wasting energy and leaving a place for bugs to get in. You could screw a surface-applied weather strip to the face of the door, but a more efficient and less obtrusive way to create a good seal is to add a door-bottom weather strip.

The weather strip shown here is available at most home centers and hardware stores. If you can't find a weather strip that's smooth on one side, you can slice off the barbed flanges from strips intended for steel or fiberglass doors.

The trickiest part of this project is cutting the bottom of the door to allow enough (but not too much) clearance to install the new weather strip. The goal is to create an even 3/8-in. space between the top of the existing threshold and the bottom of the door. Close the door and measure the largest gap by pushing a wood shim between the door and threshold until you feel resistance. Mark the shim at the door's edge. Then pull the shim out and measure the thickness of the shim where it contacted the threshold. If the gap is less than 3/8 in., calculate how much you'll have to cut off the bottom to equal 3/8 in. Mark this distance on the door at the point you measured. Then use a scribing tool to extend a mark across the bottom of the door (Photo 1).

Remove the hinge pins and move the door to a set of sawhorses. Mount a sharp blade in your circular saw and cut along the line. Protect the surface of the door with strips of masking tape. Score veneered doors along the line with a sharp utility knife before sawing them to avoid chipping the veneer.

Cut the door-bottom weather strip about 1/8 in. shorter than the width of the door and tack it to the bottom of the door with a staple gun. Rehang the door to test the fit. If it's too snug, remove the weather strip and trim a little more from the door. When the fit is perfect, remove the staples and permanently mount the weather strip to the bottom of the door with adhesive caulk and 1-in. roofing nails (Photo 2).



**1** Scribe a line on the door 3/8 in. above the top of the threshold. Remove the door and carefully cut along the line with a circular saw.



**2** Cut the door-bottom weather strip to length with a tin snips or utility knife. Apply two parallel beads of adhesive caulk the length of the door and nail the weather strip to the door.

# 15 energy-saving tips



ENERGY-SAVING  
COMPACT  
FLUORESCENT  
BULB



**1** Install and use an automatic setback (programmable) thermostat. You can reduce your heating and cooling costs by 5 to 15 percent.



**2** Insulate pipes, especially if they pass through an area you don't want heated or cooled. Have your air conditioner serviced to clean hard-to-reach evaporator coils and adjust coolant pressure to achieve maximum efficiency.



**3** Change furnace filters every month, or more often if needed.

**4** Have a furnace tuneup to clean and adjust burners and improve fuel-burning efficiency.



**5** Install light controls like motion sensors, photocell switches and timers to shut off lights automatically when they're not needed.



**6** Clean the air conditioner condenser coils and fins when you see grass and airborne debris collected on them.



**7** Shade your windows with trees, awnings, overhangs, shutters or other devices to keep direct sunlight from entering your home.



**8** To compensate for drafty windows, consider quilted curtains, which can increase your comfort and let you keep the temp down. Search online for "quilted curtain" for various sizes and colors.



**9** Seal the joints of heating and cooling ducts that run through attics and basements.



**10** Wrap the tank of your gas-burning water heater in a special fiberglass blanket to decrease heat loss. Check your owner's manual to make sure a blanket is recommended for your model.



**11** Replace worn-out thresholds and weather stripping around windows and doors.



**12** Fix leaky faucets; dripping hot water wastes a lot of energy.

**13** Buy gas stoves with electronic ignition rather than pilot lights. Install a reflector (shiny aluminum foil over cardboard will do) behind radiators to reduce heat driven into and through the wall. Save 5 percent.

**14** Reduce hot water usage by replacing high-volume showerheads with low-flow heads (2 to 3 gallons per minute).

**15** Replace recessed light fixtures with airtight models when you remodel.



# Cut energy bills with a programmable thermostat

**W**hen it comes to energy savings, few upgrades pay off as quickly as a programmable thermostat. If you turn down the heat 10 degrees during the day when no one is home and 5 degrees at night, you'll cut your energy bill by 5 to 20 percent. If you raise the temperature the same amount during the cooling season, your savings will be similar. You can do this with a manual thermostat, but a programmable model never forgets to turn down the heat at night and it can raise the temperature before you get out of bed in the morning.

Home centers carry several models of programmable thermostats. Generally, more expensive ones have more programming options. Standard programmable thermostats sold in stores work with most heating/cooling systems, new or old. But there are exceptions: Electric baseboard heat systems require a "line voltage" thermostat that's connected to much larger wires than shown here. Heat pumps often require special thermostats, too. If you can't find the one you need at a store, try [thermostatshop.com](http://thermostatshop.com). Before you shop, measure the "footprint" of the old thermostat. If you buy a new one that's at least as large, you won't be left with wallpaper gaps or paint to touch up.

Your old thermostat may look different from the one shown here, but removing it will require similar steps. Turn off the power

at the main electrical panel by switching off the furnace breaker. If the furnace circuit isn't labeled, switch on the heat (not the air conditioning) and turn off breakers until the furnace stops. Remove the old thermostat (Photo 1). Chances are, it has a small glass tube containing mercury, which is toxic. Call your city or state environmental or health department for disposal instructions.

You'll find anywhere from two to six wires connected to the old thermostat. If any of them aren't connected to the screw terminals, you won't connect them to the new thermostat either. The terminals are labeled with letters. As you remove each wire, label it to match the terminal using the tags included with the new thermostat (Photo 2). Disregard the color of the wires. When you remove the last wire, clip a clothespin to the cable so it can't slip inside the wall.

Mount the wall plate (Photo 3). In most cases, you'll simply connect the wires by matching labels to the letters on the new wall plate, but check the manufacturer's instructions to be sure. Program and install the thermostat (Photo 4). Don't forget to turn the power back on at the main panel.

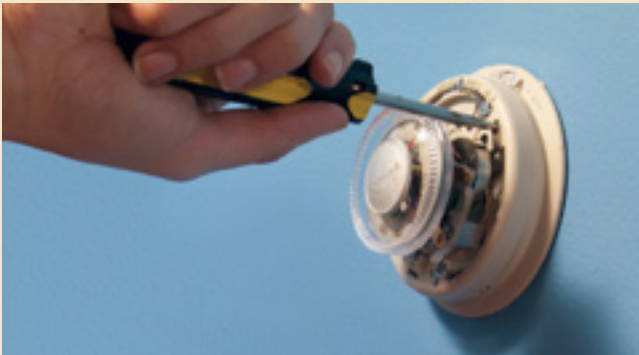

**1** Pull off the cover ring and remove the screws that fasten the thermostat to the wall plate.

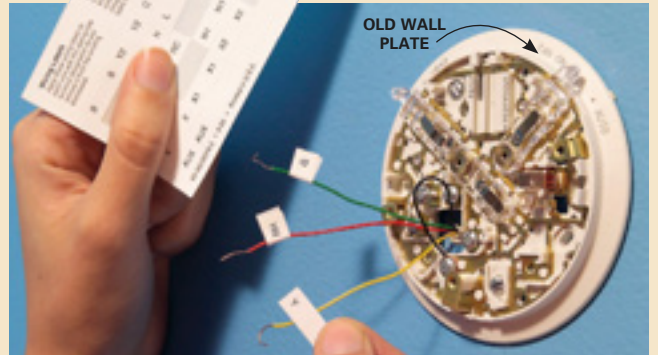

**2** Label the wires as you disconnect them from the screw terminals. Then remove the mounting screws that fasten the wall plate.



**3** Mark the new screw locations, drive in wall anchors and screw the mounting plate to the wall. Connect the wires.



**4** Install the batteries, program the thermostat and snap it onto the wall plate.

## 11 fast and easy ways to save energy

- Skip the dishwasher's drying cycle
- Clear space in front of heating units, registers and radiators
- Clean washer and dryer lint screens after every use
- Wash clothes in cold or warm water and rinse with cold
- Dry laundry loads consecutively to maximize dryer efficiency
- Close off unused rooms and lower (in the winter) and raise (in the summer) the temperatures by adjusting the registers and dampers
- Replace incandescent bulbs with efficient compact fluorescent bulbs
- Install air-sealing gaskets behind switch/outlet cover plates
- Lock windows to create a better seal
- Add weather stripping and caulking around doors and windows
- Seal around pipes and ducts that penetrate outer walls



### Cut drafts by adjusting the door sweep

If your storm door drags on the threshold or lets in blowing snow, take a look at the lower edge. Most metal storm doors have an adjustable sweep that can slide up or down. Just loosen the screws on the inside of the door, raise or lower the sweep, and then tighten the screws. If the sweep is stuck, open the door, grab the underside with both hands and pull up as if you were trying to lift the door. That will break the sweep free. Making the adjustment is easiest on a sunny day: Position the sweep so that its rubber strip presses against the threshold just enough to block out sunlight. If the rubber gasket under the sweep is damaged and won't provide a good seal, you may be able to order a new sweep. Look for the manufacturer's nameplate (usually on the hinge side of the metal frame). Then search for the manufacturer's contact information online. Some major manufacturers have online order forms.



### Turn four screws to seal a drafty door

Those big screw heads in the threshold of a newer entry door aren't just decorative; they raise or lower a narrow strip set in the threshold. So if you've noticed a draft under the door, try this: On a sunny day, turn off the lights and close nearby curtains. Lie down and look for daylight under the door. A sliver of light sneaking in at both corners of the door is normal. But if you see light between the threshold and the door, grab your screwdriver. Raise the threshold where light enters by turning the nearest screws counterclockwise. Set a straightedge (such as a framing square) on the threshold and adjust the other screws to make sure the adjustable strip is straight. Close the door and check for light. Readjust the threshold until you've eliminated the light. But don't raise the threshold so high that it presses too hard against the weather stripping on the door. A too-tight fit will wear out the weather stripping quickly.



# Stop a draft in 60 seconds

In exterior walls, electrical boxes that hold switches or outlets can let in a lot of cold air. Worse, they can let warm, moist indoor air into walls, causing problems like wood rot or peeling exterior paint. One way to stop the airflow is to seal the gaps around them and the holes inside them with caulk—messy and time-consuming. But there's a much easier way: With foam gaskets, all you have to do is unscrew the cover plate, stick the gasket in place and put the plate back on. Pick up an inexpensive pack of a dozen gaskets at home centers and hardware stores.

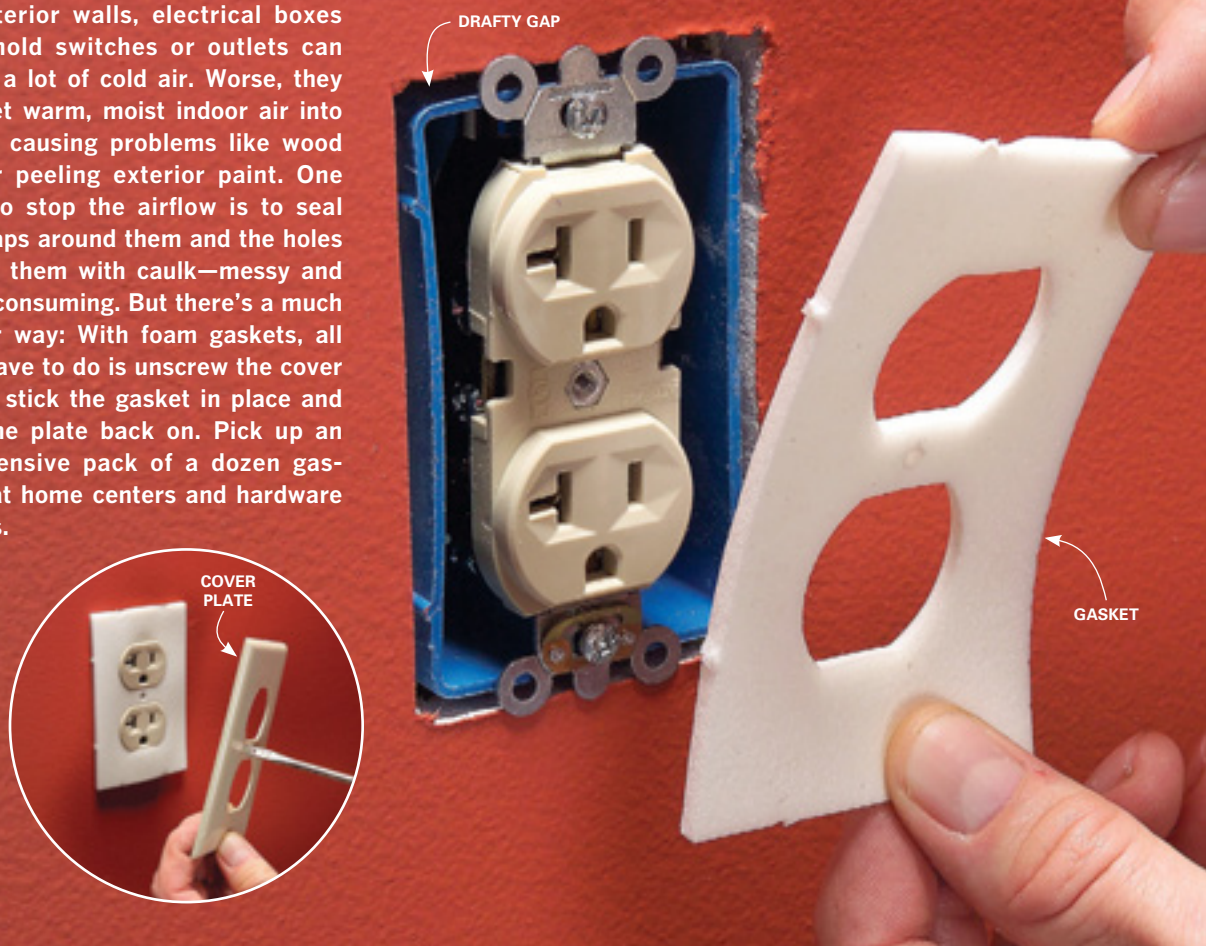

## 5 ways to use less water in your garden

- 1** It's estimated that 1,000 sq. ft. of roof can collect up to 600 gallons of water from 1 inch of rain. Make the most of summer rainstorms with a downspout attachment and rain barrel combination.
- 2** Use an outdoor water conservation kit (complete with a rain gauge, drip gauge and soil moisture meter) to determine when it's time to water. Most kits come with a lawn sprinkler timer with multiple settings, and a six-position low-flow hose nozzle.
- 3** Add water-saving polymers or hydrogels (such as Soil Moist) to the soil in your containers and hanging baskets. The crystals absorb water, releasing it when the soil is dry and reducing the need for watering. If you presoak the crystals until they are expanded, you'll be less likely to add too many to the pots, since the crystals bulk up as they absorb water.
- 4** Mulch is a true multitasker in a garden. It provides nutrients to the soil, reduces unwanted weeds and helps the soil retain its moisture. A 2- to 3-in. layer of mulch should do the trick. Don't apply it too early in the season, however; a heavy layer of mulch can actually keep the soil from warming after a cold winter.
- 5** If you live in an area where water conservation is the rule, consider xeriscaping—a landscaping technique that uses plants selected for their water efficiency. This strategy requires less maintenance than grass, and may use less than half of the water required by traditional landscapes.

Another alternative is to choose native plants. Since they've already adapted to local conditions, they're hardy and resistant to most pests and diseases and require less care than "imported" varieties.



# 4

## Backyard living



Whether your idea of backyard serenity involves a lush garden, a shady retreat or a manicured landscape, this chapter is packed with literally hundreds of tips for creating the ideal outdoor space. You'll find tips for everything from choosing flowers for your yard to caring for outdoor plants and planning your dream garden.

# Low-maintenance perennial garden



Looking for a way to reduce the weed-pulling chore around your plants that come back every year? When you start a new perennial border, spread a nonwoven polypropylene black landscape fabric over the soil. The fabric keeps weeds under control, holds heat in cool spring weather (giving your plants a faster start), and lets water soak through to the roots. At a local garden center, buy a nonbiodegradable fabric that weighs about 3.4 ozs. per square yard. U-shaped metal stakes (Photo 2), which are ideal to hold down the fabric, come in packs of 10.

While this system works best for plants already started, you can also start your perennials from seed. Simply prep the soil and plant the seed.

**Space plants according to the recommendations on the labels when you buy them. The hardy, drought-resistant plants shown here will fill in and cover the mulch completely in two years. Then they will need annual pruning or even dividing.**

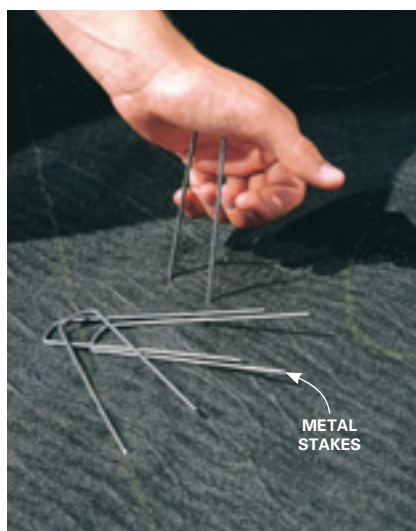

**1** Dig and break up compacted soil with a sharp spade or U-bar and remove the weeds. Mix peat moss and/or composted manure into the soil if necessary.

**2** Lay down landscape fabric, securing it at the corners with metal stakes.

**3** Draw the garden pattern, including paths, onto the fabric with a light-colored crayon or chalk. Cut the plant holes with a utility knife and set the plants.

## 5 secrets to hillside gardening

- Use dampened soil as if it were mortar to help secure rocks.
- Install drainpipes to keep water from puddling and saturating the soil.
- When taking on a hillside gardening project, account for how much time it'll take. Sometimes, it takes two or three times to get a wall right.
- Make sure you have enough rock on hand. It's easy to underestimate how much you'll need.
- Cover plants with mulch to protect them in the winter months.



## Decorate a lamppost

Train an annual like morning glory or hyacinth bean vine to crawl up a handsome lamppost on the boulevard (or lawn light). Wrap the post with chicken wire and then plant seeds (or seedlings you've started indoors) at the base of the

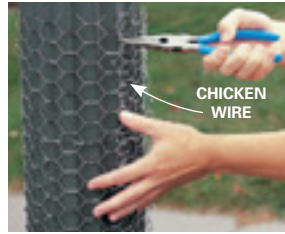

lamppost each spring.

By midsummer, the vine will encircle the lamppost. By August, it will have reached the top and be in full flower.

HYACINTH BEAN VINE



## No-stick shovel

Whether you're dealing with wet snow or mucky soil, a dose of spray lubricant on your shovel will make the sticky stuff slip right off. Use a lubricant that contains silicone or Teflon and recoat the shovel occasionally.



## Munch-proof your flower bulbs

Keep hungry critters from snacking on your freshly planted flower bulbs by staking poultry netting over the bed. You can either remove the cloth in the early spring or let plants grow through the holes and leave it throughout the growing season.

# 10 tips for no-fuss gardens

## 1 Forget the stereotypes

Not all pretty gardens are neat rows of shrubs and sprawling beds of cascading flowers. To cut down on garden upkeep, why not include a paved patio or gravel path? After all, when's the last time your driveway needed to be watered?

## 2 Use common sense

Remember those words of wisdom from your mother? They apply to planning a garden, too. Plant flowers near a faucet, keep your compost pile near your planting beds—anything to minimize trips across the yard. They may seem short, but they add up and take time.

## 3 Bigger is not always better

This one's a no-brainer: The smaller your garden, the fewer plants to care for. Don't go too tiny, but make it manageable. You can always expand later.

## 4 Space it out

If planting directions recommend leaving 6 inches between flowers, don't leave less. Your garden may seem bare at first, but it will fill in. Plant too closely now, and you'll be thinning, pruning or even removing plants later.

## 5 Think outside the (flower) box

Container gardening is easy and fun, but it can be time-consuming. Some potted plants need to be watered daily. Cut back on the number of containers in your garden, and you'll cut back on watering chores—guaranteed.

## 6 Mulch is a must

Mulching is a great way to control weeds, keep soil moist and improve the overall health of your plants. That means you spend less time weeding, watering and tending to wilted blooms.

## 7 It's easy being evergreen

When planting trees and shrubs, choose evergreens over deciduous plants, which shed seasonally and need more pruning. That's more work in the leaf-sweeping department.

## 8 Pick perennials

Perennials are perfect for an easy-care garden. They die back in winter and re-emerge in spring—no replanting necessary. Annuals, on the other hand, must be planted each year.

## 9 Know your nursery

Every region is different, so the best recommendations for easy-care plants often come from staff at a nearby garden center. Live in a dry area? Ask for a list of drought-resistant plants. You get the idea.

## 10 Stick to your plan

When buying plants, you'll almost always see a colorful bloom that looks too good to pass up. But remember, you preplanned your shopping list for a reason. The blooms on that list are the ones that are best for your garden and lifestyle. So buy them and get planting. Then kick back and enjoy your low-maintenance backyard!



Reader's Digest Assoc./GID

## Laundry jug watering can

Instead of throwing away empty laundry detergent containers, rinse them out thoroughly and then recycle them for watering plants. Drill 1/8-in. holes in the top of the cap, and a 1/2-in. hole just above the handle to relieve pressure so the water flows freely.



## 10 tips for being a good neighbor

- 10 Don't mow at the crack of dawn on weekends.
- 9 Don't hang a wind chime collection near your neighbor's bedroom window.
- 8 Don't leave your inflatable Santa up until the Fourth of July.
- 7 Don't holler "What's for dinner?" every time your neighbor starts the grill.
- 6 Don't plant invasive perennials close to a neighbor's garden.
- 5 Don't make your neighbor's bay window an automatic home run when playing baseball with the kids.
- 4 Don't run over windblown garbage can lids, even if you're in a hurry.
- 3 Don't rake only half the leaves from the maple you planted on the lot line.
- 2 Don't aim the snowblower at your neighbor's driveway.
- 1 Don't forget to smile and wave!

## Rein in an invasive plant

Plants like gooseneck loosestrife have underground rhizomes (roots) that can spread to all corners of your garden before you know it. To contain them, slice out the bottom of a plastic container with a utility knife (Photo 1) and push this "collar" into the soil (or drive it down with a mallet) to encircle the plant and its invasive root system (Photo 2). If the soil has become compacted, cut around the plant with a spade first. Note: This technique won't contain plants that spread above ground like strawberries and mint.



## Sprinkler socket system

If you use spike-type sprinklers, try setting them in permanent sockets made from 1-in. PVC pipe. These sockets will make it a snap to move the sprinklers, and they'll keep them upright and shooting water where you want it.





# 10 must-have hummingbird flowers

## 1 Bee Balm

(*Monarda didyma*)

Perennial; Zones 4 to 9.

Color: Red.

Blooms: Summer.

Size: 3 to 5 ft. tall; spreads 18 to 36 in.

Care: Moist moderately fertile soil; light shade to full sun. Deadhead flowers to keep them blooming and to limit reseeding.

## 2 Butterfly Bush

(*Buddleja* species)

Shrub; Zones 4 to 9.

Color: Purple, pink and white.

Blooms: Summer to fall.

Size: 6 to 15 ft. tall; 4 to 10 ft. wide.

Care: Grow in sun to light shade.

**Caution:** Considered invasive in some regions.

## 3 Butterfly Weed

(*Asclepias tuberosa*)

Perennial; Zones 4 to 9.

Color: Orange.

Blooms: Summer to fall.

Size: 1-1/2 to 3 ft. tall; spreads 12 in. wide.

Care: Moist well-drained to dry soil; full sun. These plants will wander to where they're best suited in your garden.

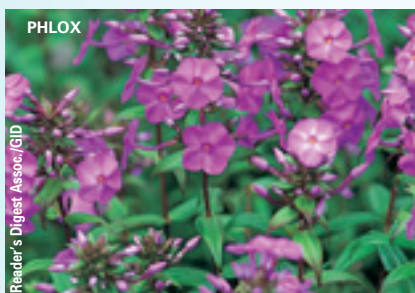

## 4 Cardinal Flower

(*Lobelia cardinalis*)

Perennial; Zones 3 to 9.

Color: Red.

Blooms: Summer.

Size: 3 to 4 ft. tall; 2 ft. wide.

Care: Fertile and moist soil, partial shade to full sun. Works beautifully with other native plantings.

## 5 Columbine

(*Aquilegia* species)

Perennial; Zones 3 to 9.

Color: Red, pink, blue, purple.

Blooms: Spring to early summer.

Size: 1 to 3 ft. tall; 6 to 24 in. wide.

Care: Low-maintenance plants that prefer moist, but not wet, soil. Reseeds itself.

## 6 Fuchsia

(*Fuchsia* species)

Perennial; Zones 10 and 11; annual to north.

Color: Red, pinks, purple, white.

Blooms: Until frost.

Size: Trailing to 3 ft. or available in shrub form.

Care: Requires moist soil: check pots twice a day in hot weather. Pinch back flowers.

## 7 Phlox

(*Phlox* species)

Perennial; Zones 3 to 8.

Color: Pink, red, blue and purple.

Blooms: Spring to fall.

Size: Up to 3 ft. tall; 12 to 24 in. wide.

Care: Needs well-draining soil in full sun. Deadhead to extend their bloom time.



## 8 Salvia

(*Salvia splendens*)

Annual.

Color: Red.

Blooms: Until frost.

Size: 1 to 3 ft. tall; 9 to 14 in. wide.

Care: Keep soil at roots cool and moist; grow in full sun. Dead-head flowers to keep blooming.

## 9 Snapdragon

(*Antirrhinum*)

Annual.

Color: Varies with variety.

Blooms: Until frost.

Size: 6 in. to 4 ft. tall; 6 in. to 2 ft. wide.

Care: Grows in full sun to part shade in moist soil. Regular deadheading needed.

## 10 Trumpet Vine

(*Campsis radicans*)

Perennial; Zones 4 to 9.

Color: Orange-red.

Blooms: Summer.

Size: Climbs to 40 ft.

Care: Grows in full sun in moist to dry soil. Tolerates poor soil and needs little or no fertilizer.

# 6 easy-to-grow backyard roses

## 1 Carefree Beauty

**Height:** 5 to 6 ft.

**Blooms:** 4- to 4-1/2-in. rosy-pink semi-double flowers.

**Bloom time:** Mid-season and repeats.

This plant was one of the finest bred by the late Dr. Griffith Buck's program at Iowa State University. He wanted roses that could meet the challenge of Midwest gardens—blazing hot summers and frigid winters.

Carefree Beauty can blanket your garden with its beautiful fragrance.

## 2 New Dawn

**Height:** Climbs 12 to 20 ft.

**Blooms:** 3- to 3-1/2-in. blush-pink double flowers.

**Bloom time:** All season.

This climbing rose is easy to train on a trellis or fence because its canes are light and flexible—just watch out for its large thorns.

New Dawn, introduced in 1930, is packed with blooms that have an aroma like ripe peaches. It was the first plant in history to receive a patent.

## 3 Knock Out

**Height:** 3 ft.

**Blooms:** 3- to 3-1/2-in. ruby-red single flowers.

**Bloom time:** All season.

When it comes to no-muss, no-fuss roses, Knock Out tops them all.

Knock Out produces brilliant single blossoms all summer long that are “self-cleaning”, which means there's no need for removing or “deadheading” faded flowers to encourage more blooms.



## 4 The Fairy

**Height:** 2 to 3 ft.

**Blooms:** 1-1/2- to 2-in. bright-pink double flowers.

**Bloom time:** Midsummer until frost.

The Fairy is a small compact shrub rose that forms a mound about 3 ft. tall and wide. It's an excellent rose to grow in the perennial garden or in large containers such as a half whiskey barrel.

It produces flowers that look like tiny boutonnières all summer, even if ignored.

## 5 Flower Carpet

**Height:** 12 to 30 in.

**Blooms:** 1-1/2- to 2-in. single or double flowers, depending on variety.

**Bloom time:** All season.

The Flower Carpet series of roses bloom profusely and are among the easiest plants to maintain.

These ground cover roses can produce more than 1,000 blooms in a single season, covering an area 3-ft. square. They're also beautiful in hanging baskets and pots.

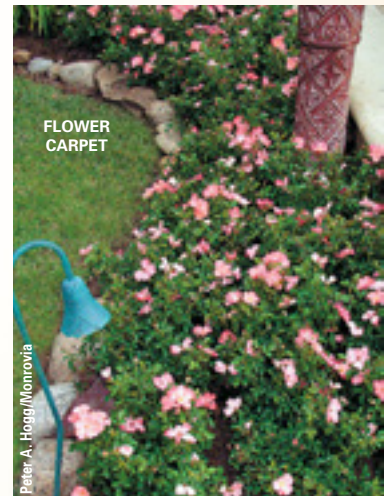

## 6 William Baffin

**Height:** 8 to 12 ft.

**Blooms:** 3- to 4-in. deep-pink flowers with a splash of white.

**Bloom time:** Midsummer and repeats.

This Canadian rose comes from the popular Explorer Series, bred for extreme cold hardiness. The vigorous rose has a large spread and jaw-dropping clusters of flowers. It brings life to fences and trellises, and has proven suitable for gardens throughout North America.

# 25 tips for planning the perfect garden

**D**ie-hard gardeners will tell you that a garden is a work in progress. Even established gardens require a little tweaking from season to season. But if you thoughtfully *plan before you plant*, your landscape will beautifully endure for years to come without costly and time-consuming alterations or additions.



**1 Take advantage of leafless panoramas.** With most trees and shrubs showing only bare bones, winter is a fine time for spotting ho-hum holes in your landscape. Check for areas that could use a punch of winter interest—consider adding evergreens, berry-bearing shrubs and trees with interesting forms or bark to boost four-season appeal.

**2 Know your site.** Spend a day or two checking how many hours of sun your gardens receive each day to ensure you incorporate light-appropriate plants into your design. Keep in mind that full-sun plants require at least 6 hours of sun, partial-shade plants need between 3 and 6 hours and shade-tolerant plants benefit from 2 or 3 hours of direct light or from receiving indirect or filtered light all day.

**3 Consider the big picture.** Sketch out an overall picture of your yard, including entertainment areas, your house and other buildings. Enlarge the sketch and mark off existing landscape features like trees, shrubs and gardens. Pencil in proposed plantings to see how they fit within the existing landscape.

**4 Allow plenty of room.** Design extra-deep borders large enough to house an array of low, medium and tall plants and that allow you extra space to add more plants as the mood strikes.

**5 Pace off measurements.** Before you sketch, estimate the amount of space you wish to dedicate to a planting bed. Use the measurements to draw a blueprint to scale on graph paper. Keeping in mind plants' mature sizes, pencil in desired plants to get a realistic idea of how many you can fit in to the space.

Search online or spend a few hours at the library flipping through gardening books and magazines in search of garden designs that appeal to your personal tastes. Then follow these 25 tips to sketch out landscapes that are sure to flourish with minimal upkeep and without pricey do-overs.

**6 Color in the lines.** On your plan, use markers, watercolors or colored pencils to color in existing plantings. Then color in your planned additions to make certain that the old and new hues complement each other.

**7 Make like a landscape pro.** Design gardens that carry the eye from earth to sky. Anchor borders and beds with structural plants, such as trees or tall shrubs, and then layer in climbing vines, smaller shrubs, varying-height perennials and sprawling ground covers.

**8 Settle on a style.** Determine whether you're going for a clipped formal look, casual cottage appeal, a native prairie or a combination of styles.

**9 Pick a palette.** Are you partial to pastels? Do red-hot hues get your creative juices flowing? Working within a color scheme will help you set a cohesive scene and prevent you from buying unsuitable plants in weaker moments.

**10 Lay the groundwork.** When planning your design, include pathways, arbors, ponds, large containers, fountains, statuary and garden benches that draw both foot traffic and attention through the garden.

**11 Cultivate perennials for pennies.** Designate a sunny corner for growing perennials from seed. Sow the seeds in early spring, and by mid- to late summer, you'll have loads of plants to fill out your borders.

**12 Add raised beds for vegetable, herb and cutting gardens.** Growing your own produce and easy-care annual flowers for summer arrangements saves money. Plus, raised beds take less time to weed.

**13 Create a budget.** Determine how much you want to spend for this year's plantings, mulch and soil amendments. Plan on putting in paths and buying the larger, structural plants first. When budgets are tight, think about filling in your design over the course of several years.

**14** **Reiterate a scheme.** Plan on replicating plant forms, colors and textures to easily fashion flow, a sense of movement and a harmonious whole garden.

**15** **Forget the finicky.** Opt to include native plants or ones that are hardy and reliable in your planting zone—you won't have to replace them down the road.

**16** **Look for deals.** Many spring garden catalogs offer inexpensive bare-root forsythia, hydrangea and red-twig dogwood saplings. The stick-like, rooted saplings take a few years to fill out and flower, but their bargain-basement prices allow you to mass their forms inexpensively or to add them throughout the landscape as a repeating element.

**17** **Invest in gardener's gold.** Incorporate plants—such as daylily, hosta, bearded iris, bee balm, purple coneflower and yarrow—that you can divide in a few years for more (free!) plants.

**18** **Think foliage, not flowers.** Sketch in plants with silver, gray, chartreuse, variegated and bright-colored foliage for gardens that remain colorful as flowers fade.

**19** **Consider every season.** Slot in plants with different bloom times to ensure a succession of blossoms throughout the year.

**20** **Plant a living wall.** Pencil in trellises, hedges and plant groupings to camouflage unattractive views, define garden rooms and buffer traffic noise.

**21** **Supersize it.** You'll fill a lot of space without spending big bucks if you include large, quick-growing plants, such as Russian sage, fountain grasses, Autumn Joy sedum, hydrangea and shrub roses like Carefree Delight, Knock Out and Magic Carpet.

**22** **Contemplate companions.** Peruse garden books, plant catalogs and search online for garden images that showcase appealing plant combinations that you can duplicate in your design.

**23** **Pair like-minded plants.** Group those with similar light, water and soil requirements together—if you plant water-thirsty cultivars with drought-tolerant plants, you're sure to lose one or both to either too-dry conditions or root rot.

**24** **Enhance the wow factor.** Add one or two plant groupings or shrubs that are sure to stop passersby in their tracks.

**25** **Vary forms and textures.** Incorporate plants with ferny fronds, grassy spires, coarse spikes, fuzzy foliage, waxy surfaces and broad leaves in varying mounded, cascading and upright forms.

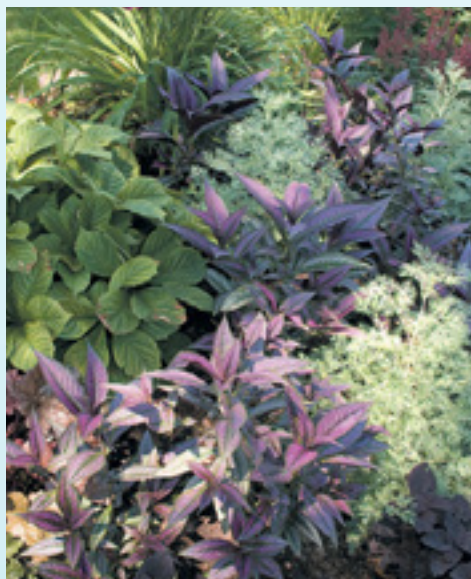

## Protect tree bark

It looks like mulch, it feels like mulch... but it's really recycled tire rubber. It keeps down weeds year after year and keeps tree bark free of weed-whip and lawn-mower injuries. The tree ring is available from Gardener's Supply Company.



# 20 tips for gardeners on the go

**T**here's no getting around it—cultivating a beautiful landscape is a lot of work. But you can labor more efficiently (and joyously) when you master a few shortcuts.

These time-saving tips cover everything from tilling and tending to plant choices and pruning, letting you make the most of your minutes in the garden.

**1 Start with good soil.** Work in compost, manure or dried peat moss for nutrient-rich planting beds. Amended soil is lighter, drains well, makes for easy weeding and allows roots to establish themselves more quickly.

**2 Keep tools handy.** Stash a spare set of hand tools and garden twine in a waterproof container in your garden. When you spot weeds, broken rose canes or a stem that needs tying up, you won't have to run to the garage or potting shed for supplies.

**3 Mow less.** Limit grassy areas to reduce time spent on lawn chores. Combine trees, shrubs, boulders and decorative mulches to fashion eye-catching, maintenance-free island beds in your front and back yards.

**4 Play in the rain.** There's no better time to visit a garden center than during a cloudburst. Nurseries are less crowded, lines are shorter, and staff members are more available to answer your questions. Once the rain eases, go out and pull weeds—even clumps of crabgrass and deep-rooted dandelions pull easily out of wet soil.

**5 Don't wear yourself out planting in shaded sites with poor soil.** When you can't get anything to grow beneath trees or along fences, set up a multitiered container garden in the shady location. Plant shade-loving perennials and compact shrubs in appropriately sized containers; set the containers on stands in varying heights. Or use simple green pots that blend into the background, and won't compete with the flowering show.

**6 Look around.** When walking or driving, take note of interesting plants and plant combinations. Write them down and take the list with you to the nursery—having an itemized list will speed up your shopping trips and reduce the urge to impulse-buy.

**7 Fertilize less often.** Nourish gardens and containers with time-release fertilizers that continue feeding for long periods of time.

**8 Avoid invaders.** Choose well-behaved perennials that don't send out runners—you'll have more time for enjoying your gardens if you don't have to keep your borders runner-free.

**9 Prune wisely.** Wait to prune evergreens, such as yews and boxwood, until they've produced most of their new growth. As a result, you won't have to prune them again until next year.

**10 Take preventive measures.** Add fresh mulch to your gardens every year. A 2- to 3-inch layer of mulch keeps weeds from sprouting and helps the soil retain water, so you'll be weeding and watering less often.

**11 Get an early start.** Divide and transplant hosta as soon as you see leaf tips breaking through the ground—since the stems and leaves have yet to unfurl, it'll be easy to cut the root-ball with a serrated knife. The planted divisions will leaf out beautifully in their new sites. You can divide and move fully leafed-out hosta, but you're likely to break off leaves and stems in the process, which results in ragged-looking plants.



**12 Consider color.** Don't waste a second searching for misplaced hand tools. Buy trowels, cultivators, forks and pruners with bright red or orange handles so you can quickly spot them amid the greenery.

**13 Place them in sight.** Plant vegetables and herbs in large containers placed near your back or front door. Since you'll see them often, you'll remember to keep them watered. And they'll be nearby when you need dinner fixings!

**14 Work smarter.** Make sure your tools are clean and sharp—they'll last longer and work better in the garden. Use ergonomically designed tools, knee pads, or kneeling mats to lessen stress on your joints—pain-free bodies also work more efficiently in the garden.

**15 Take inventory.** Make a running list of newly added plants and their locations—this will help you remember what you planted where, which will prevent the inadvertent weeding (and replacing) of a "good plant." Save perennial-plant tags and store them near your favorite how-to gardening book—you'll have all your planting information in one spot.

**16 Go native.** Buy improved varieties of plants that are native to your region. They'll thrive with very little care and are likely to be the best-looking plants in your garden.

**17 Dig once; plant many.** When you've got a bag of tulip or lily bulbs to plant, or when using annuals to edge a border, dig a large, single planting hole instead of many smaller holes. Make sure it's large enough for all the bulbs or plants to prevent overcrowding.

**18 Be prepared.** At the beginning of the season, stock up on supplies like garden twine, twist ties, garden gloves, plant supports, plant markers and bags of compost to eliminate garden-center runs and the long lines on busy gardening days.

**19 Let them do their thing.** Choose plant varieties that readily self-seed, such as corydalis, larkspur and purple cone-flower, or that quickly naturalize, such as daffodils and daylilies, to fill out borders inexpensively.

**20 Take a tour.** Walk around your gardens every day and check plants for pests and diseases—the sooner you spot a problem, the sooner you can take curative measures, which means less work later.



## Weedy tip

CARDBOARD TUBE

When you sow seeds, it can be hard to tell little weeds from the young sprouts. Cut cardboard tubes from toilet paper into one-third sections to encircle the seed and keep you from plucking out your young plants.

## Space-saving hose storage

If you have a small yard, don't waste any precious real estate on a bulky hose reel. Pound a 4-ft. length of galvanized steel pipe into the ground, coil up to 50 ft. of hose around it and top the end with a nozzle that hooks into the pipe's end. This hose holder's narrow profile is both space saving and attractive.



STEEL PIPE

## 10 tips for planting flowers in the sun

- 1** Choose the right site. Even sun lovers need a little relief, especially at midday. So avoid growing them in full sun, especially on south-facing exposures. Part-day shade minimizes stress and also preserves flower color longer.
- 2** While you can't turn down the heat, you can change the soil. Dig in plenty of organic matter prior to planting. This improves the soil's texture, fertility and ability to retain moisture. Plus, the soil stays cooler. This should be an annual task.
- 3** An inch or two of mulch can make a world of difference. Organic mulch will hold moisture in the soil, keep plant roots cool and even improve the soil as it breaks down.
- 4** Group plants with similar moisture needs in the same area. This cuts down on the special trips you'll need to make to water just one or two plants.
- 5** One of the best ways to prevent drought stress is proper watering. Instead of giving your plants frequent, shallow waterings, water less often and more deeply. Let a soaker hose give plants a good drink for several hours, or use a sprinkler at a low setting. Always water plants at ground level so that the moisture goes directly to the roots.
- 6** Try desert and dry-meadow natives and plants that survive at high altitudes. These plants survive nicely in the wild, without human help, so they're sure to survive in your backyard. Young plants purchased from native nurseries may start out as ugly ducklings but, once established, provide beauty with little care.
- 7** Hot, dry weather is the worst possible time to fertilize your flower garden. This is because plant roots respond to the difficult condition by slowing or shutting down. The nitrates in plant foods will only injure them in this dormant state.
- 8** Experiment with plant placement if you live in the South. You may find that the light is intense enough for you to grow even sun-loving plants in the shade.
- 9** Try spring bulbs! Many spring-flowering bulbs will survive in hot, dry locations, since the most extreme weather hits after they've already flowered and are resting. Mulch or cover them with other plants to keep them safe and cool.
- 10** Many ornamental grasses are prairie natives, so they're well suited to hot, dry conditions. Look for ones native to your area.

## Get rid of wasps

The magic bullet for getting rid of wasps (yellow jackets) is to destroy their nest. This is easier said than done. Bees and wasps are notorious for hiding their nests inside walls or high under shingles and eaves, where they're difficult to get at.

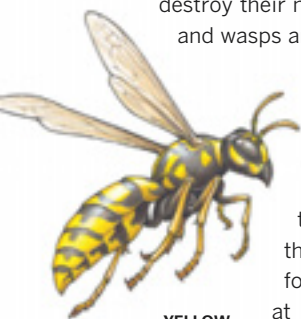

**YELLOW JACKET**

The trick to finding the nest is to observe their movements closely. You'll soon spot where they zoom into the wall of your house. Once you locate the nest, spray it with an insecticide that's formulated for killing wasps. Pick one up at a hardware store or nursery. The best time to spray is at night when the wasps are less active and inside the nest.

Be aware that these insects can be extremely aggressive, especially when their home is under attack. Some can sting repeatedly, and those stings can cause severe reactions if you're allergic. If you're on a ladder or on the roof, the last thing you want is an angry storm of wasps coming after you!

In difficult situations, have the nest professionally removed. If you decide to spray the nest yourself, make sure to wear protective clothing, including face protection, to guard against stings.

## Drive away woodpeckers

The first thing to know is what you can't do to get rid of woodpeckers. The Federal Migratory Bird Treaty Act, as well as some state laws, protect woodpeckers, which means it's unlawful to harm them. (So don't go for the pellet gun!)

Woodpeckers that make holes in your shingles or siding are either looking for food or, more likely, "drumming" to mark their territory. Unfortunately, there's no simple way to get rid of them. The best option is to harass the birds into leaving.

First, fasten sheet metal over the areas the birds are pecking. Also hang mirrors and Mylar tape nearby, for example, from the fascia (or tuck it under a row of shingles). Shiny lights and reflections sometimes scare woodpeckers away, as do owl decoys. Frankly, however, these remedies don't always work, and the longer the woodpeckers have been at your house, the harder it will be to get them to leave.

To further harass the birds, shoo them away with a broom. If you're persistent, the birds will eventually move on.

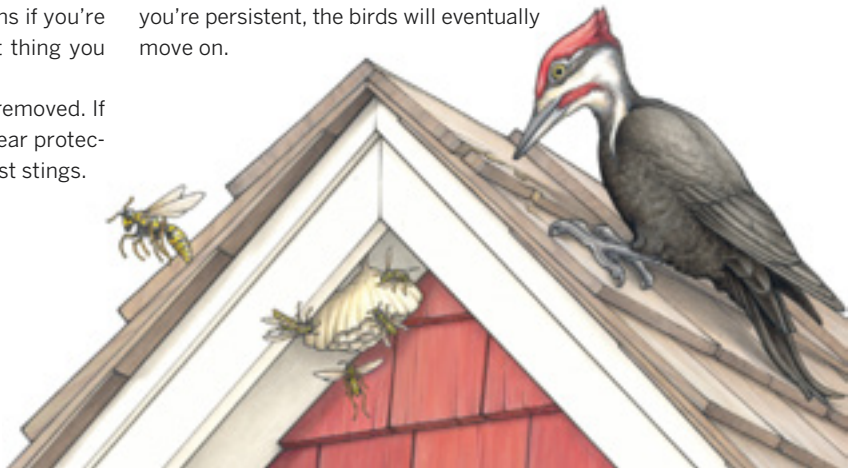



## Leaf hamper

Leaf bags have an irritating tendency to close and collapse, making them difficult to fill.

Cut out the bottom of a laundry hamper and insert the hamper into the leaf bag. Fill the bag with leaves or grass clippings and pull out the hamper when it's full.

LAUNDRY HAMPER

## 5 tips for pet-friendly gardens

- Include sweeps of lawn where dogs can wander aimlessly, roll about or frolic freely.
- Guide pets through your gardens by laying clearly defined pathways that are easy on their feet.
- Keep dogs safely contained, and keep unwanted visitors out, by fencing in your yard.
- Run lattice around the bases of porches and decks to prevent pets from burrowing into these spaces and getting stuck beneath the floorboards.
- When buying products to treat lawns or gardens, read the labels to ensure the products are pet-safe.

## 10 tips for planting flowers in the shade

- 1 Different areas of shade allow freedom of plant selection. A spot that gets morning sun will dry dew and allow plants that prosper in drier conditions to grow. A bit of afternoon sun lures reluctant blooms into developing buds.
- 2 Lousy soil is the leading cause of poor growth—not lack of sun. Add organic matter in late spring or early fall when the ground is neither soggy nor frozen.
- 3 Intermix shade plants as artistically as you would in a sunny spot. Position taller growers like astilbe in back, shorter ones like foam flower and hosta in front, and low-growing ground covers to fill in your display.
- 4 Shade doesn't mean your color choices are limited. Experiment with different plants and color schemes. A few to try are the white wands of astilbe flowers along brunnera's sprays of little blue flowers, or bugleweed's sapphire-blue spikes next to a light-hued rhododendron.
- 5 Another great way to liven up a shady spot is to pick plants with varying textures. Combine the fine leaves of ferns with bold hostas. Or mix leafy bergenia with spiky ornamental grasses such as hakone grass. Even in complete shade, you'll still have visual appeal.
- 6 For a low-maintenance, attractive shady spot, try ground covers. Plant seedlings in staggered rows rather than straight lines. They'll expand, fill the area and form a nice carpet.
- 7 Want flower color in late summer or early fall? Several plants are adapted to this. Rhododendrons bloom from early spring to midsummer with an array of color. Toad lily produces adorable violet-dabbed flowers.
- 8 Don't overpamper your shade garden in fall. Allow the leaves to break down and they'll contribute valuable humus to the soil. Remove them only if they're smothering your plants.
- 9 Consider how changing seasons affect sun and shade conditions in your yard. Even a yard filled with shade trees can support bright, spring-flowering bulbs, as long as they emerge before the trees leaf out fully.  
Pick up hints from previous seasons. If sun lovers like marigolds died where astilbe thrived, you've likely found a hot spot for a shade garden.
- 10 Resist the temptation to give shade plants a nudge by overwatering or overfertilizing them. Shade slows plant growth, so your plants in low light need less water and energy, not more. Mulching will also keep your workload light. It helps retain soil moisture and minimizes weeds.



# 50 hints for planning your best garden ever

- 1** Set aside a large-format wall calendar just for gardening notes. Use it for goals, several-step garden projects and timely reminders.
- 2** Shop early for containers, well before buying plants to fill them. There will be a bigger selection, and you can make cool-headed decisions.
- 3** Inventory your seed stash. Improperly stored seeds may have dried out and should be discarded. Be sure to store seeds in an airtight jar in the refrigerator.
- 4** Clean your hand tools in the off-season, while you have time. Chip off encrusted dirt and rub with a damp rag. Then wipe cutting surfaces with a cloth dipped in motor oil.
- 5** Review plant information in catalogs and gardening magazines. Resolve to try something new this year, and decide now where it will go in your garden.

**6** Cruise through catalogs with a marker and/or yellow sticky notes, flagging everything you might want to order. You can always pare down the list later.

**7** When ordering seeds or plants via mail order, fill out the order form (even if you intend to call in your order or place the order online). This way, you are prepared and the process goes quickly.

**8** Place orders early, before the companies get busy. These get filled faster, plus you can get exactly what you want, thus avoiding substitutions and rain checks.

**9** Stockpile soil amendments. Order or buy loam, compost and mulch weeks before you need them. When you do need them, they'll be there.

**10** Plan new beds and borders on paper. The drawing doesn't have to be sophisticated or perfect, though you should aim to make it to scale.

**11** For new plants, always note "mature plant size." Of course, results may vary in your garden, but it's still important to know what to expect to avoid future crowding.

**12** Call your nearest cooperative extension office and ask when the last predicted frost date is, or check online. This information will help you calculate how early to start seeds indoors.

**13** Start seeds of some of your favorite veggies and annuals indoors several weeks or months in advance. This way, seedlings can go right into the garden without delay when conditions are warm enough.

**14** Sketch a new plan for your vegetable garden. It's important to rotate crops in order to thwart plant-specific pests and diseases. It also gives the soil a break because different plants use more or less of certain nutrients.

**15** If you're planning a big garden installation this year—a water garden, a gazebo, a pergola—find out what's involved and plan ahead. Also, line up contractors in late winter (before they book up) if you intend to have it professionally installed.



**13**

Start some of your favorite veggies indoors from seed.

**16** Tour your yard with a sharp pair of clippers. Make way for new growth by removing deadwood, winter-damaged branches and suckers. If in doubt about whether a branch is alive, spare it for now.

**17** Feed developing seedlings with half-strength plant food every week or so. Proper care means more robust plants, improving their chances of survival when they finally move outdoors.

**18** Plant bare-root shrubs and perennials earlier in the spring than container-grown plants. Bare-root ones are still dormant or just waking up and can make a gradual transition to garden life.

**19** How do you know when it's okay to start planting? Check the soil—just scoop up a handful and squeeze it. If it's wet and soggy, wait a bit longer. If it crumbles in your hands, it's time.

**20** Help acclimate young plants before they go into the ground. Set pots and flats in a sheltered spot (under a tree, on the porch) and gradually increase natural sunlight received for a week or so—bring them in at night or cover them if frost is predicted.

**21** Lay a garden hose on the ground to visualize the size and shape of a new garden bed. Leave it in place for a few days so you can observe it from various angles and at different times of the day (to check sunlight).

**22** To plant a shrub or rosebush, dig a hole that is the same depth as but wider than the root-ball. Backfill with a mix of organic matter and existing soil.

**23** When buying perennials or annuals, resist the temptation to get blooming plants. A strong root system is much more important and will soon generate good top growth and flowers.



**24** When planting, get in the habit of creating a basin around each plant. When you water, precious moisture won't drain away but will go right to the root zone.

**25** Groom emerging perennials, cutting out last year's tangled growth. This not only makes them look a lot better, but clears the way for fresh, new growth.

**26** Plant in threes. This classic rule of thumb really works—it gives plants an opportunity to make an impression, yet not hog the garden stage. Plus, the odd number looks more natural.

**27** Make compost! It's easy, it's free and your plants will adore it. The most successful piles are in a sunny spot, about 3 ft. sq. Keep compost slightly damp and stir often.

**28** Set out a rain barrel in a convenient, but out-of-the-way, spot (usually under a downspout). Cover it with a screen to keep out leaves, dirt and mosquitoes.

**29** Where grass meets flower bed, create a shallow trench bordering the garden. Fill it with gravel or edging material if you wish. Ideally, it will halt the grass, as well as encroaching weeds.

# 50 hints for planning your best garden ever

**30** When it's in its prime, evaluate your spring bulb display. Take photos; make notes. Tuck this information away until later in the summer, when you can move bulbs and order new ones.

**31** Fight weeds early and often. They're easier to pull out by the roots after a rain or after you water. Crowds of small ones can be cut out with a few swipes of a sharp hoe.

**32** Add some quick color to your garden. Cold-tolerant annuals are great for filling the mid- to late-spring gaps—dependable favorites include pansies and snapdragons.

**33** Always fully prepare a new bed before planting. Get all weeds, roots and rocks out first. Then dig the soil to a depth of 6 to 8 in., at least, incorporating plenty of good organic matter.

**34** Newly installed transplants appreciate a little protection from sun and wind at first. Use cardboard boxes, garden fabric or even a carefully placed lawn chair.

**35** Invest in a watering wand. This hose-end attachment delivers a soft, soaking spray that young plants appreciate (it's also terrific for watering hanging baskets).

**36** Get in the habit of protecting new plants with an inch or two of mulch. This helps moderate summer's high soil temperatures, retains soil moisture and keeps weeds at bay.

**37** Clip flowers off your spring-flowering shrubs (lilacs, azaleas, spirea and the like) as they begin to fade. It helps the plant conserve energy, plus it just looks better.

**38** When watering larger plants or trees, set a hose at the base on slow trickle. Check back periodically, and turn it off for a bit if there's too much runoff. The idea is to give them a deep soaking.

**39** Put in a ground cover! Clear out an area and dig in organic matter to a depth of several inches. Stagger the plants rather than make rows. Don't plant too closely—they'll fill in.

**40** The best way to fertilize shrubs and rosebushes is with slow-release granular plant food. Follow label directions about timing and amount. Always water before and after for maximum uptake.

**41** The secrets to a great focal-point planting? Choose a large-growing plant that looks good from all angles. Elevate it and/or surround it with lower-growers. Finally, be sure to pick a color that contrasts with its surroundings.



**44**

Tie climbing plants to supports as early as possible.

**42** To make a great window box display, hold a “dress rehearsal” first—set potted plants inside and shift them around until you are satisfied you have enough and that they are well placed.

**43** Prevent lawn-mowing challenges. Elevate garden decor items on level paving blocks or stepping-stones. This applies not only to potted plants, but also urns, birdbaths, benches or sundials.

**44** For vines and climbers, put in stakes or other supports as early as possible—at planting time or soon after. This prevents puncturing the root-ball, plus it reminds you to keep after the tying. Redirect or prune back wayward stems.

**45** Deadhead all perennials and annuals that don't shed spent flowers on their own. This simple chore persuades plants to direct their energy into producing more blooms (rather than going to seed).

**46** Prevent plant diseases and insect damage by keeping your plants tidy. Get rid of damaged growth and yellowing leaves—clip them off the plant and, just as important, rake them out and away from underneath.

**47** Spring is the best time to prune, shear or shape your backyard evergreens, whether they are solo performers or part of a hedge. It's important that you use a good, sharp tool for this kind of job.

**48** Open your garden to more light and air with springtime pruning, if needed. Remove a few of the lower branches of tall trees, thin overgrown trees and shrubs and take out branches that are invading garden areas.

**49** Check the effectiveness of your watering methods. Right after you turn off the hose or sprinkler, dig down with a trowel to see how far the moisture penetrated the soil—you may be surprised.

**50** Splashy and dependable color is easy—use potted plants. Move them in and out of displays as needed. Just remember: Don't neglect watering, as containers dry out quickly.



HOOK-AND-LOOP STRIP

DOOMED

HOOK-AND-LOOP STRIP

## Drive-by weeding

Attach a bottle of herbicide to your lawn tractor with a hook-and-loop strip (like Velcro) in a spot where you can easily grab it. When you're mowing your lawn, pause the tractor and spray weeds right when you see them for weed control on the fly.

## Portable potting

Cut a piece of plywood roughly to the shape of your wheelbarrow's back end and screw a few wood cleats along the sides to keep it from slipping off while you wheel. Now you'll have both soil and a potting surface right at hand when you take the wheelbarrow to the garden.



STAY-PUT CLEAT

## 3 tips for pruning roses

Keeping your favorite roses in shape is easier than most gardeners think. In fact, it can be done in three simple steps.

**1** Remove dead and damaged stems. It's easy to tell which stems to clip—these are the ones that are dull brown or gray with no new growth. Cut near the base of the plant.

**2** Remove crossing or rubbing branches. Also take out stems that are growing toward the center of the bush or trailing on the ground.

**3** Take a step back and look at the shape. Trim branches that don't follow the shape you're looking for. The goal is to have evenly spaced stems on all sides of the bush with the center somewhat open.

## Grow tulips to bloom in the middle of winter

How about tulips under the Christmas tree this year? You don't have to wait until spring to enjoy the refreshing color of hardy bulbs like tulips, daffodils and crocuses.



By "forcing" bulbs, you can have them bloom at any time during the year. Here's how.

Fill clay pots with a light soil mix and plant the bulbs so the tip is just above the soil surface. Mix in a tablespoon of bonemeal in each pot as a fertilizer and lightly water. Set the pots in a place that's dark and cool, approximately 40 degrees F, for 12 to 14 weeks. Once small shoots start to emerge, bring the pots

out to a shaded spot for a day or two. Gradually give the plants more light and warmth. First keep them in a location where the temperature is 55 to 60 degrees F and the light is bright but indirect. Once the plants are green and about 5 in. tall, move them to a sunny window to start their bloom.

The temperature, amount of light and type of bulb will affect how long it takes for the bulbs to bloom. But it usually takes three to five weeks for the plants to show their color once they're brought out into the light.

## No-trim wall border

If you're building a fence, a retaining wall or a planter, set a course of protruding stones in the soil beneath it. That way, your mower can cut all the grass—no trimming by hand needed. The stones should protrude about 4 in. from the wall and stand at least an inch above the soil so grass doesn't creep over them. You will still have to pull out grass from between the stones occasionally.



## Plant portfolio

Store plant tags and sticks inside a cheap photo album. You can add details such as when and where the plants were purchased, special care or even the plant's location on a sketch of your yard.





Reader's Digest Assoc./GIB

## Basil

Use this popular herb in shellfish dishes, tomato sauces and salads, pizzas, pesto and more.

**Botanical name:** *Ocimum basilicum*.

**Hardiness:** Annual.

**Size:** 1–2 ft. high; up to 1 ft. wide.

**Light needs:** Full sun.

**Planting tips:** Prefers well-drained, moist, fertile soil. Start indoors and plant outside after all danger of frost has passed.

## Rosemary

Use this herb to flavor lamb, fish and potato dishes, breads, stuffings and oils.



**Botanical name:**

*Rosmarinus officinalis*.

**Hardiness:** Zones 8 to 10.

**Size:** Up to 5 ft. high and wide.

**Light needs:** Full sun.

**Planting tips:** Well-draining soil is best.

## Chives

Potato and green salads, dips, soups and egg dishes are perfect places to use chives; use their flowers in salads.

**Botanical name:** *Allium schoenoprasum*.

**Hardiness:** Zones 3 to 9.

**Size:** 1–2 ft. high.

**Light needs:** Full sun to partial shade.

**Planting tips:** Plant in well-drained,

humus-rich soil. Divide every 3 years to prevent overcrowding.

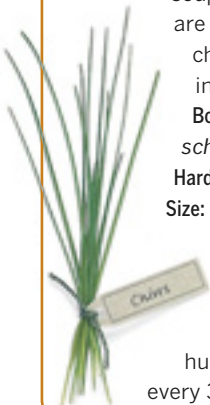

## 5 pot-perfect herbs

### Sage

Potent sage gives stuffings, soups, veggies and meats a distinct flavor.

**Botanical name:**

*Salvia officinalis*.

**Hardiness:** Zones 5 to 8.

**Size:** 2–3 ft. high; up to 3 ft. wide.

**Light needs:** Full sun.

**Planting tips:** Prefers well-drained, moderately fertile soil. Freeze seeds for at least 3 days before planting.

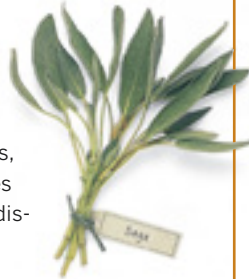

### Thyme

One of the most versatile herbs, use with fish, poultry, meats, vegetables, soups and stews, and stuffings.

**Botanical name:** *Thymus*

*vulgaris*.

**Hardiness:** Zones 4 to 9.

**Size:** 6–12 in. high; up to 16 in. wide.

**Light needs:** Full sun to partial shade.

**Planting tips:** Plant in well-draining soil of low to moderate fertility. Makes an attractive, durable ground cover between steppers along paths.



OLD HOSE

12d NAIL

STICK

## Homemade soaker hose

A sprinkler isn't always the most efficient way to water your plants, especially if you live in a hot, dry climate. Soaker hoses ensure that the plants get most of the water, and you don't need to spend money at a garden center to get one. Give your worn-out hoses a second career by converting them. Just plug the end of the hose with a round stick and perforate the hose with a sharp nail. You'll get a free soaker hose and conserve water at the same time.

## Help for root-bound plants

If you buy potted plants or shrubs, they may well be root-bound. With nowhere else to grow, roots form tight circles inside the pot. As the plant grows, the tightly wound roots prevent water and nutrients from reaching the leaves. Before planting, gently coax these roots outward with your fingers. If the roots are very stubborn, make three or four vertical cuts in the root-ball with a sharp knife. Once planted, water often to help the plant get established.



# 10 tips for mail-order seeds

**C**olorful photos and creative plant descriptions spur us to take order form and pen in hand and shop for the next growing season. But with so many catalogs offering so many planting options, ordering the right thing can be downright baffling to both novice and veteran gardeners. Here are 10 tips for navigating the mail-order maze.

**1 Know your source.** Ask friends and fellow gardeners for catalog-company recommendations. Participate in online gardening chats to discover other reliable mail-order sources.

**2 Compare and consider.** Check each company's merchandise guarantees, return guidelines and shipping costs to determine which company's policies best suit your needs.

**3 Seek inspiration.** Catalogs provide winter garden planners with a wealth of design ideas, a look at the newest plant varieties, and plants and seeds not generally available at local garden centers.

**4 Order early.** New varieties are limited and sell out quickly. Place orders as soon as possible so you don't miss out on the latest and greatest cultivars. Plants or bulbs won't be shipped until it's the proper time to plant in your area.

**5 Allow enough time.** If you order later in the season, give yourself a couple of weeks between ordering and planting or sowing. Use the time to prepare garden beds and seed-starting trays so you'll be ready when the products arrive.

**6 Save a few bucks.** You'll get a discount when you order groups of plants or collections of bulbs, plants and seeds. Order everything at once to save on shipping costs. Sign up for companies' e-mail newsletters to receive special offers and sale notifications throughout the year.

**7 Weigh your options.** Bare-root seedlings and potted plants each offer an advantage. Some plants do better when shipped as bare-roots, while others arrive more safely in pots. Bare-root plants are generally less expensive, but both bare-root and potted plants are sized to start off quickly and will do equally well if planted properly.

**8 Check the numbers.** Opt for top-size bulbs, 3-in. potted plants and No. 1 grade roses. They'll cost more, but will give you a greater and speedier return on your investment than their lesser counterparts.

**9 Start seeds to customize your landscape.** Order annual and perennial flower seeds that suit your planting palette. Try seeds for unusual and heirloom vegetable varieties that aren't available as garden-center transplants.

**10 Keep the paperwork.** Save the receipts, ordering info and cultivation instructions that come with your order. The receipts will come in handy if you're not happy with your order. The cultivation instructions include information about planting, care and pruning—you'll find that material valuable this season and for seasons to come.

## Lighten those heavy pots

Do you need an Olympic weightlifter to move around your plant pots once they're filled with soil? To lighten those large pots, fill the pot one-third to one-half full with foam packing peanuts. They not only make the pot lighter but also provide space for drainage. Fit a round piece of landscape fabric between the soil and the foam to keep the materials separate. You can use a light potting mix that contains plenty of vermiculite and peat moss to make the pot even lighter. Some packing peanuts dissolve in water; be sure to test yours before putting them in the pot.

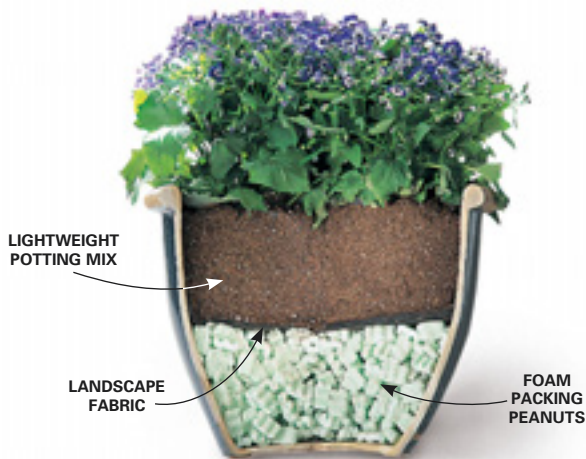



## Seedlings on the half shell

You don't have to buy seedling pots in the spring. Instead, make your own from eggshells, using the egg carton as a tray. Next time you use eggs, carefully crack them in half, rinse out the egg residue, then poke a drainage hole in the bottom of each half shell with sharp scissors or an ice pick. Fill the shells with a lightweight, sterile potting mix formulated for seed starting, and sow the seeds. When the seedlings are ready for transplanting, gently crush the eggshell with your fingers and plant them, eggshell and all. The shell will improve your soil as it decomposes.

## Bulb storage solution

Tender bulbs that must be overwintered indoors are hard to keep organized. These include canna lilies, freesias, caladiums, gladioluses, dahlias and tuberous begonias. Keep track of the bulbs by storing them in egg cartons, with each bulb identified on the top of the carton. The cartons even have ventilation holes that help prevent rot and mildew.



## 6 tips for perfect soil in raised garden beds

Perhaps the biggest advantage to growing plants in raised beds is the promise of perfect soil. Here are some tips to help ensure that you achieve success!

- Before you even think about putting up bed walls, you must thoroughly work up the existing soil.
- Adding soil to a raised bed is a lot like making cake batter—the more it's mixed, the better the results. So as you add new soil, keep tilling and working the existing and new soil together. Failure to do this will hamper drainage.
- A good general soil mix is one-third topsoil, one-third composted manure and one-third sand. Mix these together first with a shovel, then fill the raised bed.
- Maintain the soil's fertility with mulch, organic material, such as compost, leaf mold (a compost produced by tree leaves that break down) or composted manure and/or chemical fertilizers.
- Be sure to use composted manure, not fresh manure, or you'll end up with too much nitrogen in the soil, which can burn plant root systems.
- Potting mix is also acceptable for raised beds, as it contains more perlite and peat, both of which provide better drainage.



## 10 tips for planting spring bulbs

**1** Save your back when planting bulbs by using a cordless drill fit with a 24-in. bulb auger. Available at most home and garden stores, it'll make digging a snap.

**2** Plant all bulbs pointy end up. Space them three to four times their diameter apart.

Plant large bulbs, such as tulips and daffodils, about 8 in. deep in well-draining soil, 6 in. in clay soil. Smaller bulbs, like snowdrops and crocuses, should sit 3 to 5 in. deep.

**3** Try planting your bulbs in clusters. This concentrates the colors, making the flowers look like compact bouquets.

**4** Plant shorter bulbs in front. This is a good rule for bulbs that bloom at the same time, such as grape hyacinths and tulips.

It is also attractive to mix short and tall bulbs together for a multilayered effect.

**5** Critters digging up your bulbs? Try planting daffodils, hyacinths and crown imperials. Most animals don't like the way they taste.

Or lay wire mesh, such as chicken wire, on top of bulb plantings. Squirrels can't dig through it, but flowers grow through the holes just fine.

**6** Spring-flowering bulbs can be grown in warm climates. Gardeners in these areas need to select bulbs adapted to short, mild winters. Some bulbs, however, can even be chilled before they're planted. These include tulips, hyacinths and crocuses. Simply keep bulbs in the refrigerator for 12 to 16 weeks, away from ripening fruit.

**7** If summer temperatures linger after you bought your bulbs, store them in the crisper of your refrigerator until cooler temperatures return—again, away from ripening fruit, which may emit a gas that's harmful to flowering bulbs.

**8** After your spring-blooming bulbs fade, keep the leaves on the plant until they brown, or at least 6 weeks have passed since blooming. The leaves feed the bulb for flowering next spring.

**9** Apply a low-nitrogen, slow-release fertilizer at planting if bulbs are not already planted in fertile soil.

**10** Mulching reduces the risk of early sprouting and other weather-related problems. Wait until the ground freezes before covering with evergreen boughs or straw.

## 10 tips for growing plants from seed

**1** Seed companies get busy in winter and early spring as they fill orders on a first-come, first-serve basis. So if you want the best selection, order seeds early.

**2** If starting seeds indoors, grow in an area that's out of the way of household traffic. Try to set them in a spot that's warm and draft-free.

**3** The top of the refrigerator is an excellent place to sprout seeds because it generates warmth. You could even place your seed containers on top of a radiator, so long as it's not too hot and the heat is consistent.

**4** Seedlings started indoors require between 12 and 16 hours of light per day. Artificial, fluorescent light is best, and a timer will help you regulate the amount of light your seedlings receive.

**5** Don't sow too many seeds. This can lead to a forest of seedlings that grow too thickly for you to thin without damaging them. Make little furrows if you're using flats, spacing seeds up to an inch apart (closer if they are tiny seeds).

**6** Make sure planting mix does not dry out. The best way to keep seedlings consistently moist is to cover the flat loosely with plastic. Some gardeners prefer bottom watering. Set the container in a few inches of water (in the sink or a tray) and let it wick up the water it needs.

**7** When the first true leaves appear, use sharp scissors to snip some of the weaker seedlings at soil level. The seedlings you leave gain better air circulation, and their roots won't have to compete for precious nutritional resources.

**8** Fertilize developing seedlings with a diluted, half-strength flowering houseplant fertilizer every week or so until you begin "hardening off" outdoors. Proper care means more robust plants.

**9** When seedlings are well rooted, harden off transplants two weeks before moving them into their permanent location outdoors.

Set pots and flats in a sheltered spot (under a tree, on the porch) and gradually increase light received for a week or so—bring them in at night or cover them if frost is predicted.

**10** When planting seeds (or seedlings) outdoors, it's important to check the soil first. Just scoop up a handful and squeeze it. If it's wet and soggy, wait a bit longer. If it crumbles in your hand, it's time.



## Locate sprinkler lines

Before you dig, find your underground sprinkler lines to avoid damaging them. Feed fish tape through an open sprinkler head and locate the line with a metal detector.



## Digital scarecrows

Here's something useful you can do with all those useless CDs and DVDs. Drill a little hole near the edge of each disc, thread some thin wire or dental floss through the hole and hang them from your fruit trees. The silvery, flashy surface scares the birds away. You can even use the discs to protect low-lying fruit plants like strawberries. Just bend coat hangers into hooks, stick them in the ground and hang the discs from them. (It's easier than making a scarecrow.)

## Almost instant shade

Is your deck or patio delightful in spring and early summer but scorching by July? Create a mid-season awning by stringing twine or wire between 2x4s and planting fast-growing vines at the base. Given full sun and regular feedings, morning glories will cover the structure by midsummer.



## Blight-free roses

A rule of thumb for all roses, no matter where you live: Pruning to keep the center open lets the sunshine in and keeps out black spot and other such blights that love cool, moist, shady places.



## Load heavy stuff in a wheelbarrow

We all know how easy it is to move heavy stuff in a wheelbarrow, but what if you can't load it alone? Use the technique shown here to avoid having to lift heavy stones, bags of potting soil or shrubs up into a wheelbarrow. Just tip the wheelbarrow on its side and roll the stone into it. Then push on the top edge while you lift on the bottom to right the wheelbarrow. Be careful when you reach the top not to tip the wheelbarrow over in the opposite direction. Balance the load in the wheelbarrow and you're ready to roll.

# 37 plants you don't want to grow

**W**hen you think of unwanted plants, dandelions, quack grass and other weeds that bully their way into your yard and garden probably come to mind. But, occasionally, a seedy character gets planted that either takes over the garden, gets you itching or causes a whopper of a stomachache (or worse) if eaten.

So how do you know what plants to avoid in your landscape? Start by identifying what's already growing and make sure none of them made this blacklist. Then read on to learn why some seemingly innocent-looking beauties are the biggest backyard troublemakers...and how you can fight back!

## Too much of a good thing

It's covered with pretty, purple flower spikes from late summer through fall. A long-lived perennial, it adapts to a wide range of growing conditions. Plus, it makes a beautiful cut flower. It's a



Reader's Digest Assoc./GID

gardener's dream come true, right? Wrong!

It's purple loosestrife. And as many gardeners throughout the United States and Canada know, this invasive blooming beauty, which has taken over many a backyard garden, has now taken to our natural wetlands. A vigorous grower, it crowds out native plants, eliminating cover and essential food sources needed by wetland wildlife.

Purple loosestrife isn't the only invasive landscape plant causing problems in natural spaces. Norway and Amur maples have joined buckthorn and honeysuckle as woodland invaders.

The lesson here? Do a little research before adding new plants to your landscape. Select plants suited for the growing conditions

in your backyard. Then, check with your local extension service, an area nursery or online for a list of invasive species that plague your region.

Keep in mind, however, that it's possible for a plant to be invasive in one area yet struggle to survive in another. Butterfly bush, tama-

## Plants to avoid!

### MAY Cause skin irritation

Garlic mustard  
Gas plant  
Juniper  
Meadow rue  
Pencil cactus (euphorbia)  
Poison ivy  
Poison oak  
Poison sumac  
Stinging nettle  
Wild parsnip

### Poisonous plants

Arborvitae foliage  
Castor bean  
Datura (angel's trumpet)  
Deadly nightshade  
Dieffenbachia  
Flowering tobacco  
Lily-of-the-valley  
Nuts of horse chestnut or buckeye trees  
Oleander  
Privet  
Red fruit of yew  
Virginia creeper berries  
Water hemlock

### Invasive Plants

Algerian ivy  
Barberry  
Buckthorn  
Butterfly bush  
Garlic mustard—  
not planted, but needs  
to be controlled  
Honeysuckle  
Japanese knotweed  
Moneywort  
Multiflora rose  
Norway maple  
Purple loosestrife  
Russian olive  
Tamarisk  
Teasel

risk and ivy are a few plants that are invasive in warmer locales but have a hard time making it in cold, wet and other less-than-ideal growing conditions.

## Look, but don't touch

Gas plant, meadow rue, euphorbia and hyacinths are common landscape plants that can leave some gardeners covered with an itchy, red rash. Though the list of potential irritation-inducing plants is long, not all gardeners will be affected by some—or even any—of these plants.

The best tactics to avoid the itch are to be careful about what you plant, be diligent about wearing protective garden garb and learn maintenance strategies that'll keep your landscape looking good ... and your skin rash-free.

Start by taking note of how the offending plant causes the rash, and make changes based on that information. For instance, some gardeners with sensitive skin develop a rash after only a

## buyer beware

**Some seed mixes have purple loosestrife in them. Be sure to check the label for this pretty invader.**

few minutes of handling prickly plants. If this is you, be sure to wear heavy clothing and leather gloves, or convince your thicker-skinned gardening friends to help out.

Infamous plants like poison ivy or even some ornamental euphorbias also contain irritants in their saps that result in a painful and itchy rash. Wear long sleeves if you plan to garden around or weed these irritants out of your landscape. It's also a good idea to immediately wash the irritating oils off your body and clothing to avoid further exposure and expansion of the rash.

Oddly enough, gas plant, wild parsnip and garlic mustard sap cause a rash only when the irritating oils are exposed to sunlight. That's why some gardeners weed at dusk or by landscape lighting to eliminate the risk. But if you can work around these irritants only by the light of day, be sure to wear long sleeves and gloves and wash skin immediately.

## Deadly beauties

It may surprise you to learn just how many plants can cause stomachaches, diarrhea or even death when eaten. Gardeners with small children and pets may want to avoid planting the very toxic datura and castor bean. The seed in the fleshy red fruit of the yew, the nuts of horse chestnut trees and all parts of the oleander plant are also toxic. And don't forget the mushrooms Mother Nature sometimes scatters in the yard.

That said, perhaps the most important thing to do for children is to curb their sense of adventure when it comes to eating items from the landscape.

You should also keep houseplants, seeds and bulbs out of the reach of small children and pets. And store all garden chemicals in their original containers in a secure location.

Lastly, reduce the risk by identifying and labeling all your landscape plants. As a gardener, it is great to have a record of what's planted where. But as a parent or pet owner, you never know when this kind of information will be useful in the case of an emergency.



DATURA (ANGEL'S TRUMPET)

Reader's Digest Assoc./GID

## Top 10 tips for care-free perennials

- 1** When you're choosing among unfamiliar perennials at your local garden center, ask the staff for recommendations. They'll let you know which ones are the most successful for your growing conditions.
- 2** As you plan your perennial garden, consider planting each selection in groups of threes. Your plants will make more of an impact in groups, and odd numbers make for a more natural design.
- 3** Don't throw away the identification tags when you bring home new plants. Keeping the tags on file will give you easy access to essential plant information.
- 4** Low maintenance for the future requires a little care at the start. Follow the guidelines for light, spacing and soil conditions to determine placement before you start digging.
- 5** Once your perennials are in their beds, add a layer of organic mulch to your garden. Mulch helps the soil conserve water, inhibits weed growth and enriches the soil as it breaks down.
- 6** For easy and efficient watering, run drip or soaker hoses through your garden beds. Unlike sprinklers, drip hoses stay in place all season. They deliver water directly to plant roots and offer the benefits of deep watering while using less water than sprinklers.
- 7** You'll get more from your plant budget by choosing perennials that you can divide or propagate easily. These techniques range from slicing through a root clump to setting a cut stem into a pot of perlite. Check the plant's identification tag for details.
- 8** Be careful when choosing plants that are claimed to spread quickly. Some perennials are irritatingly invasive, which means they'll be popping up and you'll be pulling them out of inappropriate places all over your yard.
- 9** Even the most care-free perennials can have occasional problems with pests or diseases. Look for inexpensive, eco-friendly solutions before reaching for harsh or toxic treatments that can cause more problems later on.
- 10** For less maintenance around your yard, create a mowing strip between your perennial beds and your lawn. Dig a shallow channel along the edge of the beds, and fill it with wood chips or pavers. It should keep both the grass and the lawn mower out of your flowers.



## Easy-read rain gauge

Drip food coloring into the bottom of your rain gauge the next time you empty it out. When it showers, the coloring will reconstitute and tint the water to make the gauge easier to read.



## Ice cube trick

Tired of water draining too quickly through hanging baskets? Try ice cubes. They'll melt slowly enough so plants can absorb as much water as they need.



## Potted plant transport

The spaces between the rungs of a stepladder are great spots to transport tender plants. No more messy spills during turns!

## 7 tips on weed-killing

**1** Don't waste your money or time applying herbicides (except preemergence treatments) when there aren't any weeds. Just fertilize instead.

**2** Use a pump-up type sprayer to spot-treat weeds that are limited to specific areas. Only mix the amount of liquids you need that day. They have a very short shelf life once mixed with water.

**3** The soil should be moist and the grass growing before you apply any herbicides.

**4** Apply liquid herbicides only on calm, windless mornings. When the wind's blowing, you'll not only waste material but also possibly kill nearby shrubs and flowers.



**5** Water your lawn thoroughly before applying any weed treatment.

**6** Granular herbicides work poorly on viney broadleaves like clover or creeping Charlie. Use liquid herbicides on those. Some work better on hard-to-kill broadleaf weeds. Ask for advice at the garden center.

**7** Buy concentrated liquid herbicides; they're cheaper than premixed solutions.

# Planning a backyard gravel path

Gravel is the easiest path material to handle and the least expensive. It feels soft underfoot, but it's solid enough to handle a loaded wheelbarrow. And although it looks informal, it can complement a formal garden, especially if you add a stone border.

But gravel has limitations. It's not ideal for a walkway right to the back door—pebbles will stick to your shoes and end up on the kitchen floor. It's not the best choice if you have to shovel snow off it in winter. You'll end up picking rocks out of your garden and yard. And it's tough on bare feet!

## Materials

Gravel is available in many sizes and colors. Ask for gravel that compacts well. It'll typically have stones ranging in size from 3/4 in. down to a powder. Smaller stones (3/8 in.) are the most comfortable underfoot. Larger (3/4 in.) stones stay put better during rainstorms.



**1** Gravel paths are easy to build. Although these paths look informal, a limestone border like this one really dresses them up.



**3** Tumbled stone and other stone borders require fitting, but they look the most natural.

Buy your gravel from a landscape supplier or directly from a quarry.

## Key construction details

Laying a gravel path is mostly shovel and wheelbarrow work. You first flatten the pathway with a spade, skimming off sod if you're crossing a lawn. Then set the borders and pour in about 3 in. of gravel.

### tip

Have your gravel dumped on your driveway. Shoveling gravel off a lawn or tarp wastes time.



**2** Metal edging is easy to install, makes nice curves and costs less than other edging materials.



**4** Bricks fit together easily and form highly traditional border patterns.



# Special section: Lawn care made easy

## Three key steps to a great lawn from scratch



**Step 1.** Loosen the ground to a depth of 4 to 6 in. A rented power tiller will make this job easier. Rake the loosened soil to remove plant material and stones. Break up clumps and finish with a smooth surface.



**Step 2.** Apply starter fertilizer and then the grass seed. Sow the seeds in two directions with a drop spreader. Lightly rake the seeds into the soil with a leaf rake. You don't need to bury all the seed, just most of it.

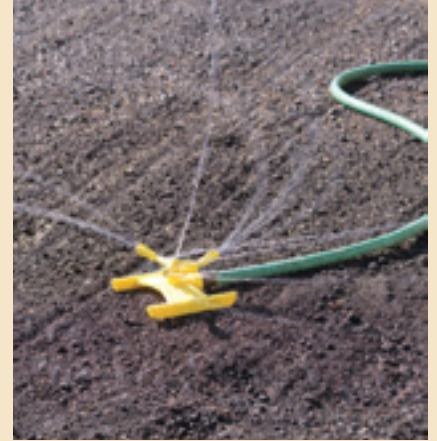

**Step 3.** Water to keep the top few inches of soil moist until germination. After germination, apply more water but less often to promote deep roots.

## How to restore bare spots

Bare spots in your yard need to be replanted with grass. Reseed in the spring or fall when the temperature is 60 to 70 degrees F. To start, water the bare spot until it's wet to a depth of at least 3-1/2 in. Water at intervals throughout the day (for at least 15 minutes every two to three hours) rather than continuously. With constant soaking, the water just runs off. Check the depth of the water penetration by digging into the ground and lifting up the soil (Photo 1). You'll be able to see or feel how deep the water has seeped in.

Make a series of 3/8-in.-deep recesses in the ground, 1 in. apart, with a square-head shovel. Spread the grass seed over the bare spot. Then flip over a garden rake and use the "knuckles" to cover the seed with soil (Photo 2). Lightly water the area in the morning and evening until the grass starts to grow.

If you want the seed to grow fast, plant Scotts PatchMaster, which is grass seed with fertilizer and mulch. After making the recesses in the ground, spread PatchMaster seed over the bare spot (Photo 3). Water twice daily.



## 5 tips on watering your lawn

**1** The morning hours are the optimal watering time because the grass blades will dry before nighttime. Lawns that stay moist at night encourage harmful mold and fungal growth. Quit watering one to two hours before sunset. You'll also lose more water to evaporation if you water during hot afternoons.

**2** An impact (or impulse) sprinkler will lose 20 percent less of its water to evaporation than the types of sprinklers that send thin streams of water into the air. But oscillating sprinklers do work better on smaller, rectangular yards.

**3** Never give your yard just a "sip" of water, thinking that's better than nothing. That encourages shallow rather than healthier deep roots.

**4** Don't overwater, either. If water puddles or is streaming off the yard, you're simply wasting water.

**5** Attach a water timer to your hose, and set it each time you water. Once you know how long to water, a water timer will do the thinking for you. You won't have to worry about shutting off the water at the right time.

## Perfect lawn patch

Here's how to cut out damaged grass and cut a sod patch that fits perfectly in its place: Lay a piece of sod over the bad spot and slice through both the sod and the damaged turf below with a sharp spade. Then dig out the bad spot and plug in the new sod. Water it daily for a couple of weeks and it will blend invisibly into your lawn.



## 5 tips on lawn mowing

**1** Change mowing directions each time you mow to lessen soil compaction (from you with a walk-behind mower or the tires from a riding mower).

**2** Mow with a sharp cutting blade. A dull blade rips off the blades of grass rather than cutting them. That stresses the grass and leaves a brown shredded end on each blade, which detracts from a lush, healthy look. It's not a bad idea to have two blades on hand so you'll always have a sharp one when the other's at the sharpening shop.

**3** Rake or catch clippings if it's necessary. Long grass should be removed if it's so long that it clumps when it's discharged. Those clumps can smother or even kill underlying grass and encourage fungi and molds.

**4** In climates that receive snow, reduce the first and last seasonal mowing to 1-1/2 to 1-3/4 in. That will discourage snow mold and reduce shrew and vole damage during the winter, especially with fescues and bluegrass.

**5** If you've neglected your lawn and the grass is long, just cut off the top one-third of it on the first mowing. Let it recuperate from the stress for a few days before mowing again. This time, too, cut off no more than one-third until you reach the right height.

## 7 tips on fertilizing

**1** Select fertilizers that are a combination of "slow" and "fast" release. They give the grass both immediate and longer-term nutrients.

**2** Never fertilize wet or damp grass; wait until it's completely dry. Otherwise, the fertilizer will stick to the blades and could damage them. An exception to this rule is combination fertilizer/herbicides. They should be applied to damp grass, when no rain is forecast (and no watering) for 48 hours. Water after that.

**3** Use a "broadcast" spreader to distribute the fertilizer because it spews out the granules, distributing them faster and more evenly than a "drop" spreader.

**4** Fill the spreader on a hard surface like a driveway, patio or sidewalk—never on the grass. You'll be able to reclaim any spills and keep them from damaging the grass. Use a shop vacuum to pick up spills. You'll never be able to sweep up fine granules.

**5** Water thoroughly after fertilizing to dissolve and drive the fertilizer into the soil.

**6** If you aerate in the fall, apply the fertilizer afterward so the fertilizer will drop into the aeration holes for better soil penetration.

**7** Never apply fertilizer when the ground is frozen because it won't penetrate the soil. Instead the fertilizer will run off and find its way into streams and waterways.



## Save your lawn products

Leave a bag of fertilizer or weed killer open for long and it'll soak up moisture from the air and won't go through a spreader. Even grass seed could use an extra layer of protection from a damp concrete floor. Place opened bags of lawn products in large resealable plastic bags. The products will be free of clumps and pests when you need them.



## 5 tips on aerating

- 1** Aerate only during cool weather. The exposed roots surrounding holes will dry out on hot summer days.
- 2** Wait two years before aerating newly seeded yards and one year before aerating newly sodded yards.
- 3** Make two passes at 90-degree angles. In heavily compacted soils, make a third diagonal pass for thorough aeration or before seeding.
- 4** Don't bother aerating lawns growing in sand unless there is a buildup of thatch.
- 5** The soil should be moist 3 to 4 in. deep before aerating. Otherwise the tines won't penetrate and extract the necessary 1- to 1-1/2-in. plugs.

## 6 steps to quick mower starts

Your lawn isn't the only thing that needs end-of-the-season attention. After your last cutting of the year, follow these steps, and your mower will be one pull away from firing up next spring.

- 1** Check the blade. It needs sharpening if the edge is rounded. Take it to a professional or do it yourself with a file, Dremel-type tool or bench grinder. If you remove much metal, buy a balancing wheel to check that both sides of the blade weigh the same.
- 2** Tip the mower up, and remove debris and rust from the blades, canopy and anywhere else you can reach with a stiff-bristled brush.
- 3** Oil exposed metal parts with WD-40 or a rag soaked in lubricant. Grease all bearings to prevent rusting over the winter.
- 4** Check power cords on electrical mowers for wear. Damage to the cord can be dangerous if left untended.
- 5** Turn off the fuel supply and remove spark plugs before doing any work. Be sure to "stabilize" all fuel being stored over winter so that it doesn't become gummy. Purchase fuel stabilizers at hardware stores or lawn-mower dealers.
- 6** Check your mower's owner's manual for detailed end-of-season engine, filter and oil maintenance tips and procedures.



5

# Add curb appeal



If you're looking for ways to boost your home's curb appeal, this chapter will help you get the job done. Whether you want to add freestanding masonry walls or just a few low-cost accents, you'll find more than three dozen tips and ideas to inspire you. You'll be surprised by the huge impact small items can make!

# 10 high-impact projects for instant curb appeal



**T**here are dozens of small, inexpensive improvements you can do that add up to a dramatic upgrade. This article contains a menu of ideas to consider.

Tackle first things first. If the paint on your house is peeling, faded or outdated, break out the paintbrush. No matter what other projects you do, your house will never reach maximum curb appeal with shabby-looking paint.

Also consider how much time you're willing to

invest, in terms of both undertaking the project and maintaining it afterward. Lining a walkway with bricks or installing a screen door can eat up a day, but neither requires much maintenance. Installing a flower box is quick and easy but requires regular upkeep. And keep the big picture in mind. If you're replacing your old light fixture with a brass one, your door hardware and house numbers will probably look best in brass too.

Go at it, add your own touches and have fun!

# 1 Paint, paint, paint

**Time:** Half day and up

Whether you paint your front door, your trim or your entire house, few projects can transform a house as dramatically and inexpensively as paint. Top-notch paint costs only a few dollars more per gallon, but it will cover better, go on smoother and last longer than the cheap stuff—it's a smart investment.

A few rules of thumb: If you want a small house to look larger, paint it white. If your house is a mishmash of styles or has sagging soffits or other flaws, paint everything the same color to help visually unify the house.

Several paint manufacturers have computer software that allows you to mock up different paint color schemes on a digital image of your house (or on a house close in style supplied by the program). Benjamin Moore, Glidden and Sherwin-Williams offer this.



# 2 Install new house numbers

**Time:** 1 hour

Replace shabby or dated-looking numbers with ones made of brass, aluminum or stainless steel. They'll look best if the finish matches that of the light fixture and door hardware. You can buy do-it-yourself address plaque kits from Ace Hardware. For custom plaques, contact Address Plaques or BestNest.



# 3 Upgrade your mailbox

**Time:** 1 hour and up

Whether you have a box mounted to the house, a letter slot next to the door or a freestanding box on a post near the street, a new mailbox can add a splash of curb appeal. Purchase an approved mailbox and follow regulations regarding height; for example, curbside mailboxes must be mounted so bottoms are 42 to 48 in. above the ground. And remember, hanging plants and flowers growing around a mailbox may increase curb appeal, but the bees and other stinging insects these plants attract aren't always your mail carrier's best friend.

MailboxWorks has a wide selection of mailboxes and letter slots.



## 4 Line a walkway with bricks or pavers

**Time:** Half to a full day

Is your concrete walkway in decent—but boring—shape? Adding color, texture and width to an existing walkway by lining it with pavers is a whole lot easier and cheaper than replacing it. Stone, clay and concrete pavers are all good choices. The basic procedure involves digging a trench one paver wide along the walkway, leveling in a bed of sand or pea gravel, then setting and tamping pavers so they're flush with the top of the walkway.



## 5 Replace a light fixture

**Time:** 1 to 2 hours

Consider function as well as style when selecting a fixture; it should light up your steps, house numbers and door without being too dominant. To simplify the project, buy a fixture that has the same mounting system or screw spacing as the existing fixture.

Make certain the power is off and the new fixture is rated for exterior use before installing it. Some sconce-style lights are now available with unobtrusive, built-in motion detectors.



## 6 Plant a tree

**Time:** 2 to 4 hours

Plant a tree and you get not only curb appeal but also shade, an improved view from the inside and fall color. Before planting, determine the mature size of the tree. Plant it far enough away from the house so limbs won't overhang the roof or cause other problems. A tree planted in the right place can help block wind and act as a mini solar device by screening out the hot summer sun when it's in full leaf and letting in welcome winter sunshine when it's leafless. Consider planting two trees to "frame" the house or entryway. Foundation plantings are another way to add appeal.



### 5 reasons to plant a tree

- 1 Trees boost the market value of your home.
- 2 One young tree has the cooling effect of 20 air conditioners.
- 3 Trees can cut your heating costs by 20 percent to 50 percent, and cooling costs by 30 percent.
- 4 In lab tests, a tree-filled scene reduced test subjects' stress within five minutes.
- 5 One acre of trees absorbs six tons of carbon dioxide and produces four tons of oxygen. That's enough fresh air to sustain 18 people for a year.

# 7 Add low-voltage lighting

**Time:** 2 hours and up

Low-voltage lighting can dramatically improve your home's nighttime curb appeal, and by lighting walkways and dark corners, it can improve safety and security as well. Lighting can be grouped into three basic categories: downlights, uplights and specialty lights. Buy a transformer that includes a timer or light sensor so the lights automatically turn on and off.



# 9 Install a new storm door

**Time:** 2 to 4 hours

Even if your primary door remains the same, a storm door with an oval window or decorative glass can act as a great cover-up. It can add security and increase your home's energy efficiency.

Self-storing units with glass and screen panels that can be adjusted in tracks according to season are the most convenient. Those with interchangeable screens and storm panels have a cleaner, uninterrupted look but require a safe place to store the unused panel.

# 10 Install flower boxes

**Time:** 1 hour to install store-bought boxes; 3 to 4 hours to build and install your own

Few projects add as much charm and color to a house as flowers in window boxes. These work best when mounted below double-hung, slide-by or stationary windows—casement and other swing-out window sashes will decapitate the flowers. Use a plastic liner to prolong the life of the planter and simplify fall cleanup.

Easier yet, arrange container gardens in pots and planters on the front stoop or along the walkway.



# 8 Install shutters

**Time:** 1 to 2 hours to paint, 1/2 to 1 hour to install

Decorative shutters can add color, quaintness and depth to a house. Shutters with louvers or raised panels have a traditional look; those with decorative cutouts have more of a cottage or country feel.

For an authentic look, mount wood shutters using special shutter hinges and keep them pinned against the house with old-fashioned shutter dogs. Shutter clips are available for "invisibly" mounting vinyl shutters.



# 6 inexpensive strategies to spruce up your front entry



## 1 Build arbors and trellises

Arbors flanking an entry walkway bring some vertical features to an otherwise plain yard and give you a handsome place to hang potted plants. And a trellis covered with vines is especially effective for enlivening a drab wall, like alongside a garage. The features take at least a weekend to build.

## 2 Put in a small patio

A simple flagstone or paver brick patio furnished with an outdoor dining set is the perfect spot to watch the kids play in the yard and entertain guests. Practically speaking, patios help drain water away from the house and are a great solution for areas that won't support grass.

## 3 Add mounds to flat areas

If you're stuck with a perfectly flat yard, a mounded "island" of earth is a great place to isolate and display plantings, yard ornaments, boulders or other eye-catching features. A yard with contours looks more natural than a flat yard. Order a dump truck's worth of topsoil, or use fill generated from patio or pond excavations.

## Edge a concrete walk

Dress up a plain concrete walk with a border of bricks placed in a line or a basketweave pattern. Bluestone or flagstone pieces, cut at the quarry in pieces 6 in. to 1 ft. wide and at least 1 ft. long, also look handsome along the edges of a walk or a cement patio. Large Belgian pavers like those shown here work well too: Their extra width keeps weeds away from the walk; their weight holds them firmly in place; and their warm, golden color and rough texture make a nice contrast with plain concrete.

No matter which type you choose, set the pavers in about 2 in. of pea gravel. It'll keep the pavers from settling or heaving and lets you easily adjust their height during installation.



### tip: Hire a design service

Don't be shy about getting professional help with designing your overall yard plan. Many nurseries and landscape suppliers offer design services, and many companies will subtract your design fee from future purchases, so the design work may not cost anything.

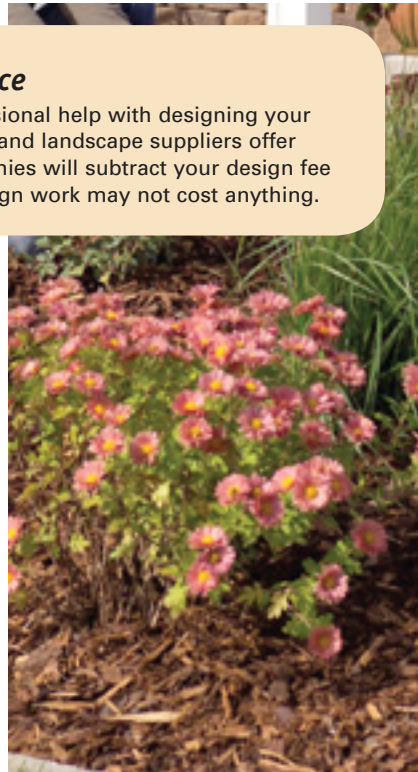
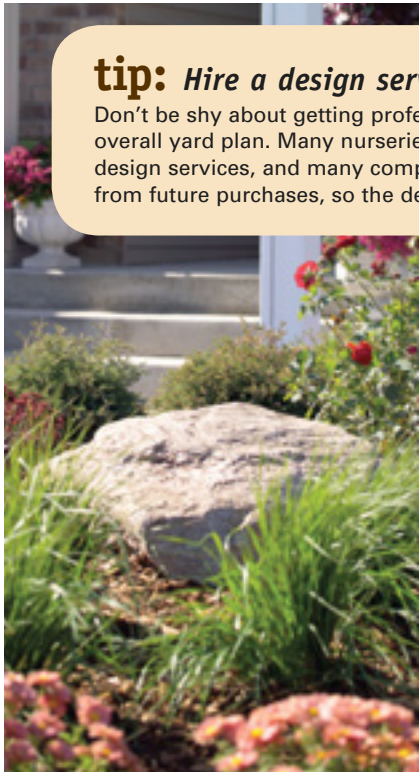

## 4 Feature a few boulders

Boulders are eye-catching and are natural locations for grasses, flowers and other garden plants. Prices vary greatly and giant boulders will have to be delivered and placed. Whatever sizes you choose, nest the boulders into the ground a bit. They should look like they were left from a receding glacier—not like they were just rolled off the back of a pickup!

## 5 Go for green

Unless you're a seasoned gardener, get help with selecting and placing plants. Bring photos or a scale drawing of planting areas to the nursery and get help from a knowledgeable salesperson. Your goals are to choose a variety of plants that lend color throughout the season (including winter), and to position them well, so their mature growth heights and widths fill in the planting beds and blend well.

## 6 Erect stone entry walls

Low stone walls are striking features that can define your entry and guide visitors up the walk. Natural stone is ideal but difficult to set. The decorative concrete units shown here are relatively inexpensive and easy to install. They subtly separate seating areas from public sidewalks and streets. And they're also great places for casual seating and potted plants.





# 6 steps to a

# beautiful landscape

## 1 Talk it out

An important part of the design process is creating a space that's suited to your needs—and those of your family.

Begin by making a list of all the ways you would like to use your backyard. Talk with everyone in the family, including the youngest members.

You may have small children who need a grassy area to play, or you may plan to entertain and need a dining area. This kind of evaluation will help you determine the basic components of your landscape.

## 2 Look around

Once you've decided which features you'd like in the backyard, take time to evaluate your current landscape. Are there existing trees and plants that you want to incorporate into the design? Do any hardscape features exist, such as patios or barbecues?

This is also a good time to make note of any slopes or valleys in the yard and the sun exposure that different areas receive.

## 3 Put it on paper

Now you're ready to get out a piece of paper and start planning. Begin by drawing everything that will remain in the finished yard, such as existing trees, shrubs, decks and walkways. Don't forget to include stationary items that you'd rather conceal, like an LP gas tank. Then look at your basic wants list and assign a space for each area. This will give you an overall conceptual plan.

When doing this, keep in mind the relationship between the yard and your house. For instance, you'll probably want the outdoor living area adjacent to the house for easy access. So start there and work around it. The child's play area may work best in a spot with both grass and shade, but still within view of the kitchen window or patio. A flower garden would provide a colorful display outside the living room or bedroom windows.

## 4 Take time to dream

Now it's time for the fun part—dreaming! Go through books and magazines, search online and clip pictures of yards you like. Look around the neighborhood, go on garden walks or head to the local nursery to find ideas that you want to incorporate into your space.

Do you like formal or informal styles, symmetrical or natural looks? Do you prefer shady yards with a lot of trees, or sunny ones where flowers dominate?

Consider all kinds of plants and structures. A mixture of trees, shrubs, vines, perennials and annuals will produce a beautiful and balanced yard, then include accents like arbors or birdbaths.

## 5 Pause for a reality check

Once you've determined what you like, apply it to your landscape to see if it works. This is where advice from a landscape designer or local nursery might come in handy. Are the plants you've selected hardy in your area? Is this going to be the easy-care yard you were hoping for, or will it require a little more upkeep? Will the plants work in your soil and sun conditions?

Keep in mind, too, how the plants' future growth will affect your plans. The sun exposure often changes as plants mature. You may need sun-loving plants in an area until the tree you've planted grows to offer shade.

Think about how the landscape will work together. Fragrant plants are a wonderful accent around a patio, while evergreens are appropriate to border a pool or spa. Once you've determined what will really work in your yard, add those plants and features to your diagram. It's important to put everything down on paper.

## 6 Get planting

You've finally reached the installation phase of your backyard landscape. Although it'd be nice to complete your plans all at once, that's usually not possible. Instead, start with the areas you'll use most—a patio or deck, for instance—and complete your vision as time and money become available. And since you have the yard planned on paper, it should be easy to work in stages. So dig in and get growing!

# 5 downspout upgrades

Water puddling around a foundation from an ineffective downspout can create major problems, ranging from damp basements

to structural damage. It's worth finding a system that works for you. Here are the pros and cons of a variety of options.

## 1 Vinyl recoiling sleeves

These install with a simple strap and automatically unfurl as they fill with water.

**Pros:** They move water away from the foundation by dispersing it sprinkler-style, then recoil when it stops raining. They work well when you need to move water only 3 or 4 ft. away from the house to a slope where it will then run off naturally.

**Cons:** You need to remove the end clip to flush out built-up debris, and you should remove the entire sleeve in freezing temperatures to prevent damage.



## 2 Flip-up/swiveling/telescoping spouts

Some simply flip up and out of the way, while others telescope for extra length and swivel 180 degrees to direct water away from the building at any angle.

**Pros:** The open-top design makes them easy to maintain. Fully extended, some carry water up to 6 ft. away from the foundation.

**Cons:** The most expensive option, one vulnerable to damage in areas where there's lots of foot traffic.

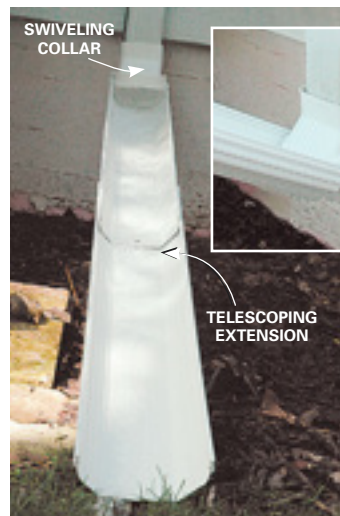

## 3 Flexible accordion spouts

Attaches to your downspout with two screws.

**Pros:** Can be easily twisted to go around corners, shrubs or other obstacles and are easily moved when mowing. Two or more segments can be snapped together, making them ideal for situations where you need to move water over longer distances.

**Cons:** They look a little industrial—but none of these products is going to win any beauty contests.



## 4 A below-grade extension

You'll need a downspout adapter and end cap, some 4-in. PVC pipe and adapters.

**Pros:** This is especially effective when the extension needs to cross a walkway or is in a "knock-off-prone" area.

**Cons:** Connecting and burying everything takes more time than other methods, but it's the most permanent solution. For this system to work, your lawn needs a little slope; make certain the pipe slants away from the house at least 1/4 in. per ft. If it clogs, clean it out with a plumbing snake.



## 5 Do-it-yourself flip-up spout

Create your own by removing a 2-in. section from the top of a standard extension, then use two screws to create a "hinge" when securing it to the downspout elbow.

**Pros:** When it's time to mow, simply flip the extension up. It's inexpensive.

**Cons:** They are subject to "operator malfunction"—if they're left in the "up" position, you'll get water around your foundation during a storm.

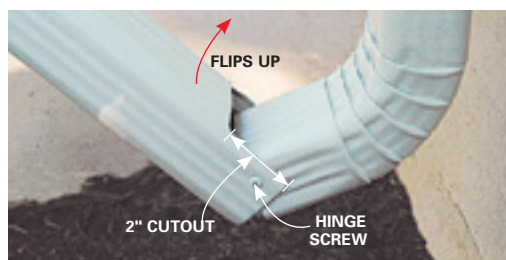



# 5 tips to avoid property line confusion

- 1 Garages.** Double-check setback requirements before you pour the slab. Roof overhangs may also have to meet similar rules. Also check size and height limitations.
- 2 Sheds.** These often have size and height limitations in addition to setback requirements. They may have design restrictions as well.
- 3 Front porches.** Surprise! Front porches, like the main house structure, often must meet setback requirements from the street.
- 4 Fences.** Check specific fence setback rules. Observe height restrictions. Most rules require the nicest side of the fence

to face outward. Fences are a common source of neighborhood irritation.

- 5 Decks.** Setbacks for decks may be the same as for the house. Always call the planning office with questions before you start your project or you too could be in for a costly but completely avoidable mistake.



## Stop moles from tearing up your yard

Moles can eat their weight in worms and grubs every day, so they find healthy, well-watered lawns—which are full of worms and grubs—very attractive. Tunneling as fast as a foot per minute under the sod, one mole can make an average yard look like an army invaded it.

To their credit, moles do a good job of aerating the soil and controlling Japanese beetle larvae and other harmful bugs, and they don't eat flowers or plants. If you can live with them, they generally won't cause any serious, long-term damage to your yard. However, if you can't, you'll have to trap or remove them. The population density of moles is generally no more than three per acre, so catching even one might take care of the problem.

Livetrapping by setting a deep bucket under an active tunnel is sometimes effective. To set up a live trap, dig a hole at the tunnel deep enough to set a 2- to 5-gallon bucket below the level of the tunnel. Pack the dirt around the edge of the bucket, then cover the hole with sod or plywood so you can check the hole daily. The mole will fall in, and then you can take it to a new location.

However, the most effective, time-tested method is to set up a spring-loaded prong or choker-loop trap that is activated

when the mole pushes against it.

For the spring trap, flatten an area of the tunnel slightly bigger than the base of the trap and set the trap over it. Follow the manufacturer's directions to arm the trap, then cover it with a 5-gallon bucket to keep kids and pets away. Remove it and the mole after it's been triggered, or try a different tunnel if it hasn't been triggered after several days.

Whether you set up a live or a spring-loaded trap, the first step is to locate the active tunnels. Step on the tunnels you see in one or two spots to collapse them, then check those spots the next day. If the tunnel has been dug out again, it's an active one, and a good spot to set a trap.



**Moles dig tunnels just under the turf, searching for worms and grubs.**

## Hardy street-side plants

Life on the street is tough on plants, too. They must survive exhaust fumes, heat and light reflected from the pavement, cramped roots, and winter road salt. In these areas, start with street-tough plants such as salvia, ornamental oregano, cranesbill geranium and sedum. But even these plants benefit from some extra attention.

Enriching the soil quality is essential. Do this by elevating the bed with timbers and adding a 3-in.-thick layer of mulch to conserve soil moisture and protect roots. Water these plants frequently and deeply. Also, hose off the foliage to remove dust, soot and salt, being sure to spray even the underside of the leaves.



# Stepping-stone path

Stepping-stone paths offer many of the advantages of concrete sidewalks and paver stone but without all the work, expense and mess. You can save wear and tear on your lawn on heavily used routes or take a trip to the garden without getting your feet wet from the morning dew. Since you only remove enough sod to place the stones, you can lay this path without tearing up your lawn. And if you pile the dirt and sod on a tarp as you work, cleanup can be easy too.

Almost any type of flat stones will work as long as they're about 2 in. thick. You'll need a 60-lb. bag of playground sand for every 10 stones.



**1** Space the stepping-stones along the path to match your stride. Using the stones as patterns, cut through the sod around each stone with a drywall keyhole saw or a bread knife.

**2** Move the stone to the side and dig out the sod with a trowel. Dig the hole 1 in. deeper than the thickness of the stone to allow for the sand base.

**3** Roughly level a 1-in. layer of sand in the hole. Set the stone on the sand and wiggle it until it's flush with the surrounding sod. Add or remove sand as necessary.

## Chimney-flue planters

Want unique, tough terra cotta planters? Go to a brick supplier and buy 3-ft. lengths of clay chimney flue liner. Cut them to different heights using a circular saw fitted with a masonry Carborundum abrasive cutting wheel. Each wheel will cut about two liners before wearing out.

The possibilities are endless: You can put the liners on a deck or patio to make a patio garden or accent your landscaping wherever you like—just pick your spots and bury the ends in the soil a little. Group the liners for an elegant herb garden or use them to border landscaped stairs.

Fill the liners with gravel for drainage, leaving at least 8 in. at the top for potting soil. Because the water can drain, the liners won't crack if they freeze. Or simply set plastic pots right on top of the gravel and you'll be able to bring in the plants for the winter.



## 23 home security tips

**Security measures.** These days security is no longer a simple pursuit: Leaving on a living room lamp and canceling the mail when heading off for the week won't fool intruders worth their rap sheet. There is a science to being—and feeling—safe. Just look below. These 23 tips—14 for the outside of the home, nine for the inside—that will tighten up security at your home.

### Outside

- 1 No place to hide.** Trimming back shrubs and other plantings near the house deprives prowlers of a place to hide. Strategically placed thorny plants—a hedge of rosebushes ringing the perimeter of the house, for example—can also be a deterrent. Consider putting gravel on pathways and under windows to prevent an intruder from approaching silently.
- 6 Get a good look.** Install a wide-angle peephole on the entry door.
- 7 Install deadbolt locks** on all exterior doors, and on doors leading to the basement and the garage. If double-cylinder deadbolts are used, always keep a key within easy reach of the door to prevent being trapped in a fire.



- 2 Down and out.** Protect basement windows with metal grates or bars or specially designed plastic bubbles. However, check local building and fire codes before blocking the exit from any window.
- 3 Window of opportunity?** Secure ground-level double-hung windows with keyed pin locks. Also install these locks on any upper-level double-hung windows that are accessible from garage roofs, shed roofs, etc.
- 4 Bulk up the doors.** Secure bulkhead-type basement doors from the underside with sliding crossbars. Recess the hinge barrels in concrete to protect them.
- 5 Show them the door.** Placing lights on both sides of the entrance door should provide ample nighttime illumination, even if one light fails.
- 8 The strong, solid type.** Make sure all exterior doors are solid-core to provide strength against intruders.
- 9 Moving targets.** Motion-detecting lights go on when someone approaches the house and enters the sensory field. Install them on your house's exterior so they illuminate areas that can't be seen from the street—back and side yards, for example, as well as areas that are screened by shrubs, trees, or other vegetation. Place the lights high enough so they can't be reached without a ladder.

**10 Open-and-shut case.** If you have an automatic garage door opener, consider replacing it with one that has a “rolling code.” This defeats the “code grabbing” devices that thieves sometimes possess, and that allow them to access the electronic code that opens your door. To improve security and safety, you can also purchase remote-control devices that will open the garage doors and turn on interior and exterior lights—all without your having to get out of the car.

**11 Don't forget the garage.** Reinforce the panels on wooden garage doors. If there are windows in the doors, consider replacing them with shatterproof glass. When going away for long periods, padlock the garage door track, or if it is an electric door, turn off the power.

**12 Grounding an intruder.** Use vinyl rather than metal drainpipes, since vinyl is less likely to support a climber. Also, cut back tree limbs that a burglar could use to climb onto the roof. Place trellises and picnic tables away from the house.

**13 Sliding home.** Secure sliding glass doors with keyed pin locks that are screwed into the inside frame. The fixed panel of the door should also be screwed into the frame so it can't be lifted out.

**14 A well-lit path.** Installing low-voltage ground lighting makes outdoor walkways safer at night. Place timers or light sensors on the lights so they go on automatically at dusk.

## Inside

**15 If you smell gas,** evacuate the house immediately. Call the fire department from a neighbor's house—using a landline phone or any appliance can be dangerous when gas is in the air.

**16 Be savvy about smoke.** Install at least one smoke detector on each level of the home, including the basement and attic, and in the garage. If bedrooms are more than 40 ft. apart, place a smoke detector outside each bedroom. Smoke detectors are also needed at the top of stairwells and at the bottom of the basement stairs. Smoke detectors can be part of a whole-house security system that includes protection against break-ins.

**17 Also be savvy about security.** An electronic security system is a good idea. The most secure are the monitored systems, but unmonitored systems also help protect against burglary. Put a sign in front of the house indicating the presence of an alarm system or a watchdog.

**18 Quick call.** Teach young children to call 9-1-1 if there is an emergency.

**19 Put timers on lights** and possibly on appliances such as the air conditioner, television, and radio so you can program them to go on and off while you are away.

**20 Store fire extinguishers** in various locations in the house, most importantly the kitchen, basement, and any room where there is a fireplace.

**21 Store valuables** in a fireproof, waterproof safe to protect them from theft, flooding and fire.

**22 A well-planned escape.** Make sure there is a fire escape ladder in each bedroom and in any other frequently used room above the ground floor.

**23 Carbon monoxide alert.** Install a carbon monoxide detector on each level of the house, including the basement and attic, and in the garage. However, do not place a detector near a source of combustion, such as a furnace or gas stove.

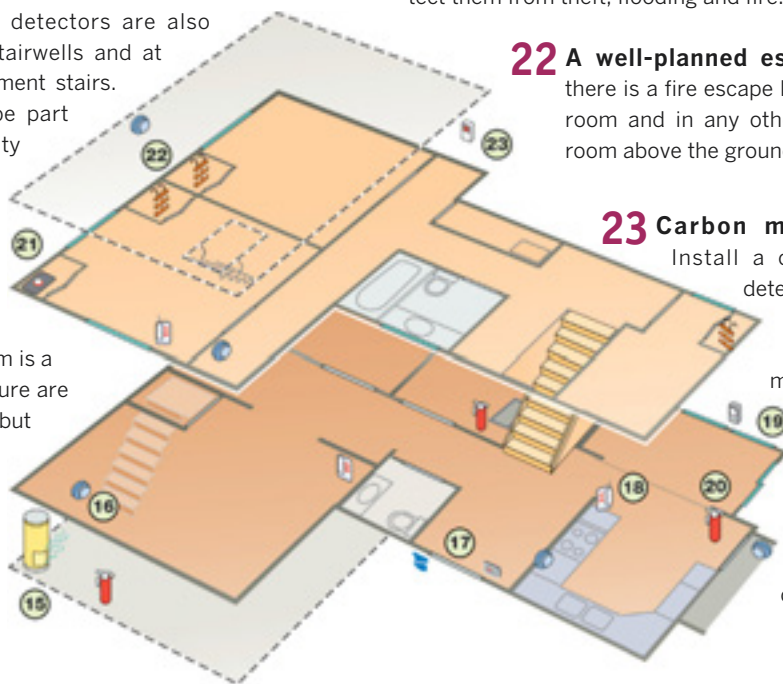

## A 10-point checklist before you go away

Write up a point-by-point to-do list to ensure that you don't forget anything in the rush to get out the door. A good checklist might look something like this:

- Make sure the oven is off.
- Arrange for pet and plant care.
- Fill prescriptions, and take copies with you in case you run out of or lose a medication.
- Pack first-aid supplies and a sewing kit. Also take sunscreen, sunglasses and electrical converters, if needed.
- Clean the kitchen and bathroom and throw out the trash to make sure insects don't move in while you're gone.
- Move light-sensitive objects out of the sun, and make sure rain can't enter through any window screens.
- If you keep spare keys hidden under doormats or rocks, remove them. Don't leave keys to double-lock windows and doors near breakable windows.
- Turn on security alarms and timers.
- Tell a neighbor you'll be away.
- And finally, lock all windows and doors, including garage doors and outdoor sheds.

## Safety in a second

If toddlers visit your home only occasionally, you don't have to mar your cabinetry with a safety latch to make it child-proof. Keep a set of drawers from being opened by sliding a yardstick through the handles. Now the kids are safe and you didn't have to buy a special safety latch or get out your drill.

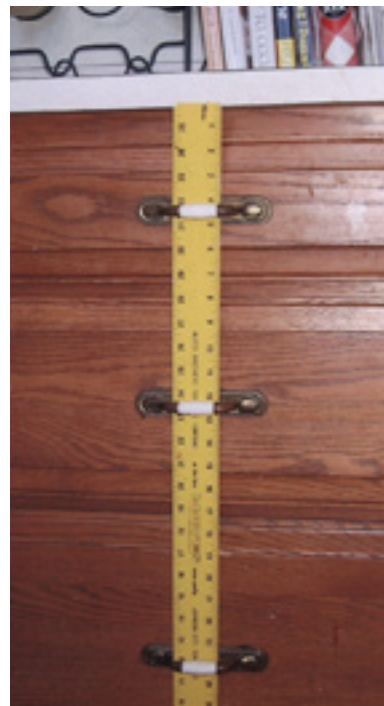

## 7 safety tips for kids' play areas

Keep in mind that more than 50,000 children injure themselves annually on home playgrounds, mostly by falling off equipment, according to the U.S. Consumer Product Safety Commission. Here are some basic safety tips to follow, as recommended by the CPSC:

- Provide a protective surface to cushion falls. Shredded bark mulch and wood chips should be 6 in. deep for any surface that's 6 ft. high, 9 in. deep for a 10-ft.-high surface, and 1 ft. deep for an 11-ft.-high surface.
- Extend protective surfaces at least 6 ft. around the perimeter of all equipment.
- Install handrails on any platform more than 30 in. high.
- To avoid head entrapment, any openings that are closed on all sides—such as the spaces between railing slats—should either be less than 3-1/2 in. or more than 9 in. wide.
- Place swings at least 8 in. apart from each other, as well as from any support frame.
- "S" hooks must be closed tightly so they can't entangle clothing.
- Moving parts should be enclosed to avoid pinching.

## Keep spare keys in a lockbox



Hiding a house key is risky business. Clever (or lucky) burglars sometimes find hidden keys. And insurance companies may refuse to cover your losses if there's no sign of forced entry. The solution is a combination lockbox. Screw it to a fence post or your house in an inconspicuous spot. But don't use the short, wimpy screws provided by the manufacturer. A crook could pry off the box, take it home and patiently saw it open. Instead use four No. 10 x 2-in. screws, preferably stainless steel.





# 6

## Tips for everyday life



Sometimes the best tips are the ones that solve everyday problems or simplify our lives. This chapter offers just that—more than 75 ideas for eliminating around-the-house problems and making your home more comfortable and enjoyable. Many of these tips make use of common household products and will save you time, money and headaches down the road.



# 11 tips to prevent household disasters



## 1 Turn off the water supply before going on vacation

Water damage from undetected plumbing leaks will quickly ruin ceilings, floors and walls, leading to repair bills in the thousands. This is especially true if you're away on vacation. Yes, such a leak is unlikely, but insurance companies report hundreds of these incidents every year. Look for the main valve near the water meter and turn it clockwise to close it. If it's stuck, leaks or doesn't turn on again, hire a plumber to replace it. The ice maker in your refrigerator may freeze up while you're gone, so shut it off too or thaw it with a hair dryer when you return.

## 2 Use metal tubing rather than plastic for ice maker supply lines

If you've had mice in your home, use a copper (type L) or braided stainless steel line rather than a plastic supply line for the ice maker in your refrigerator. Mice like to run behind refrigerators and occasionally chew holes in plastic lines, causing a leak that can ruin floors and ceilings before you detect it. Plastic tubes also can harden over time and crack. Find metal ice maker lines at home centers and wherever appliances are sold.

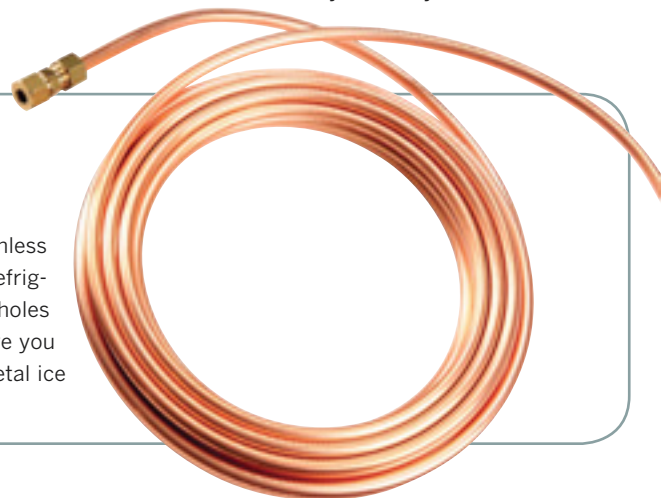

### 3 Test your sump pump before the beginning of the rainy season

The most common time for a sump pump to fail is the first heavy rainfall after months of not being used. The submerged or partially submerged portions of cast iron pumps can rust and seize. And they'll burn out when they switch on. Don't get caught with your pump down and the water rising. After a long dry (unused) spell, pour a bucket or two of water into the sump to make sure the pump kicks on.



### 4 Monitor foundation or wall cracks

Hairline cracks in a concrete foundation are normal, but cracks that continue to widen spell trouble. They'll eventually cause shifting and cracking in the walls above, tilt floors and move doors and windows so they won't open and close. The movement is glacially slow. To help you spot it, measure and record the gap size. Check it every few months. If the cracks widen, call in a foundation specialist to assess the foundation. Solutions can be expensive, but the cost of ignoring the problem is greater. A major foundation fix can cost thousands.



### 5 Trim trees around the house so dead branches won't crash down on the roof

Insurance companies get a flood of tree-related claims after major storms. You can't prevent all of these incidents, but many you can, if you trim out overhanging branches and dying trees just waiting to fall. Major tree trimming is dangerous and not a do-it-yourself project. Call in a tree service to trim all tall trees around your home every few years. Don't procrastinate. Spending a few hundred dollars now could save you several thousands in roof repairs later.



### 6 Put splash pans under washers and water heaters to catch leaks

Once upon a time, water heaters and clothes washers always sat on concrete floors near drains, where spills and leaks wouldn't hurt anything. Now they often sit on framed wood floors, sometimes on the second floor, where spills, overflows, broken hoses or slow drips can cause stains, rot and other potentially expensive water damage. You can buy special

plash pans at home centers and appliance dealers that catch slow leaks and mild overflows. Some have drain holes where you can connect a tube that leads to a floor drain. They won't stop burst water lines or massive overflows, but they're cheap insurance against water damage caused by minor spills and leaks.

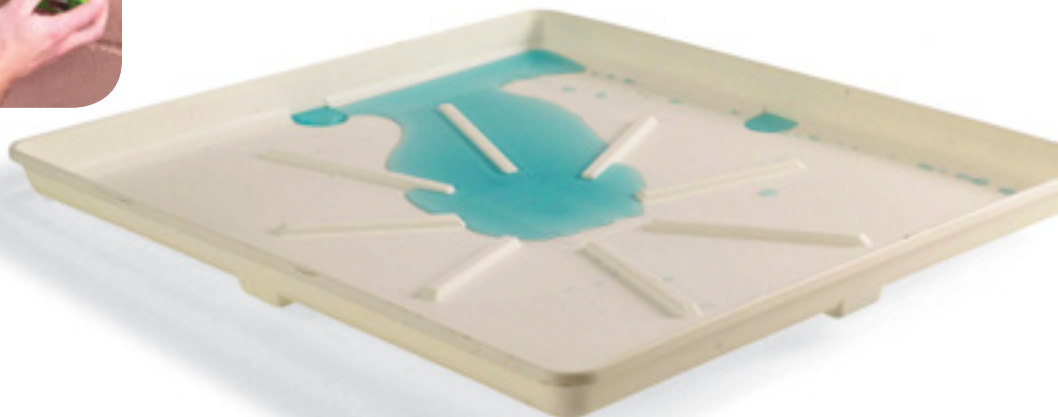

## 7 Buy no-burst hoses for your clothes washer

If your current hoses are more than five years old, replace them with no-burst hoses. The supply hoses to your clothes washer are always under pressure, just like the supply pipes in your water system. However, eventually the rubber will harden, crack and leak. If undetected, the leak can cause extensive water damage. An inexpensive solution is to buy no-burst hoses. These high-quality hoses are less likely to leak and they'll keep any leak from becoming a torrent. They are available at home centers, hardware stores and appliance stores.



## 10 Add 6-ft.-long downspout extensions

A 1-in. rainfall drops about 650 gallons of water on an average roof. And your downspouts concentrate all that water in only a few spots. If dumped too close to the house, the water will undermine your foundation, causing it to leak, shift or crack—very expensive to fix. Downspout extensions will prevent most major problems, including wet basements, cracked foundation walls, and termite and carpenter ant infestations.

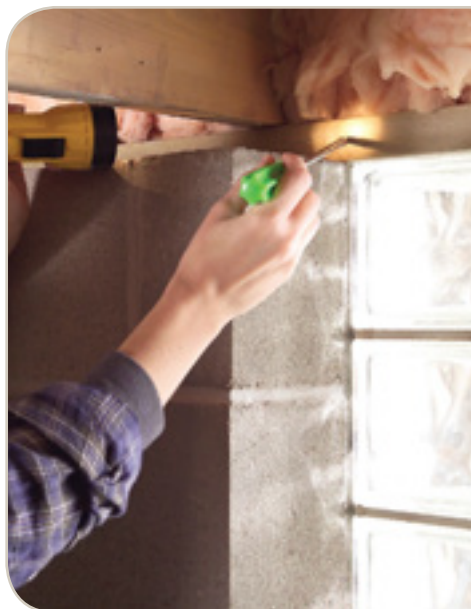

## 8 Once a year, inspect your foundation for termite tunnels

Pull out your flashlight and walk around your home, examining the foundation, both inside and out, to inspect for termite tunnels. Much of the damage termites do is invisible, inside walls and floors. Take the time to look for telltale sawdust and tunnels, because termites can do major damage before you even know they're there. If you spot signs of termites, call in a professional exterminator.

## 9 Strap your water heater if you live in an earthquake-prone region

Earth tremors can tip water heaters and break the gas lines that lead to them, causing either water damage, or worse, an explosion and fire. Water heater straps can prevent this disaster. (They're required in California and other regions.) In earthquake-prone regions, you can find them at home centers and hardware stores. Otherwise, order them online.



## 11 Install surge protectors to protect your electronics and prevent data loss

Electronic devices are sensitive and highly vulnerable to momentary power surges, especially powerful ones induced by lightning. Losing a computer is bad enough, but losing photos, music and other irreplaceable stuff on your hard drive is often much worse. Insulate your data from this danger by plugging devices into a surge protector. Better surge protectors will have the following ratings printed somewhere on the box: meets UL 1449 or IEEE 587; clamps at 330 volts or lower; can absorb at least 100 joules of energy or more; and handles telephone lines and video cables as well.

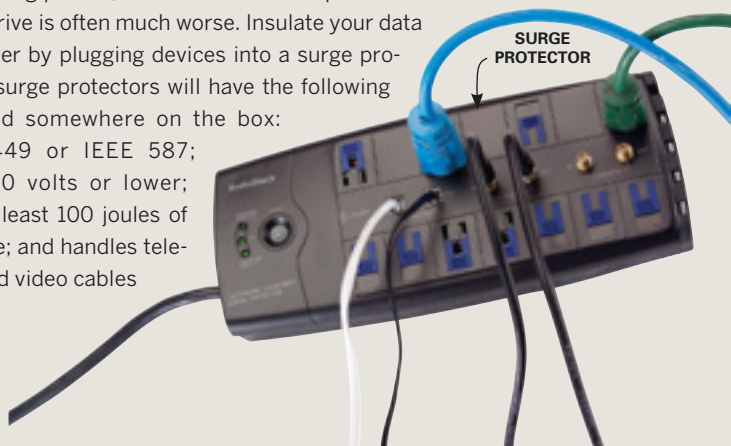

## Flashlight glass finder

Cleaning up broken glass is a real pain, but it's nothing compared with a glass shard in the foot. Get a flashlight and turn off the overhead lights. Scan the floor with the flashlight from a low angle and the shards will glisten, making even the littlest piece stand out.

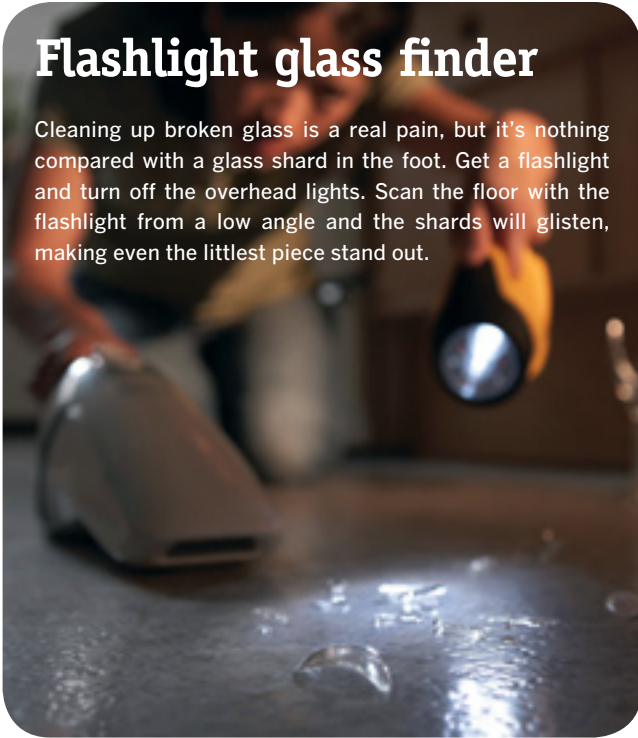

## Money measurement



A dollar bill is 6.14 in. long. But you don't need to memorize that; just remember that a buck is about 6 in. long and you'll always have an approximate measuring tool in your wallet.

## Tennis ball parking guide

This could be the most popular tip ever! For perfect parking every time, thread a string through a tennis ball and hang it from the garage ceiling. Position the ball so your vehicle lands in the center of the garage when the ball touches the windshield.



## Waistline ruler

Become your own measuring device! Glue a flexible tape measure to the inside of your belt and you'll always have it on hand. Find one for a couple of bucks at any fabric store.



## Stop sink-sprayer hang-ups

If you have to jiggle the hose as you pull out your kitchen sink sprayer, chances are the hose is catching on the shutoff valves. For smooth operation, slip 1/2-in. foam pipe insulation over the pipes and shutoff handles. Tape it if it won't stay put. Get the insulation at home centers.



## Photo positioning tip 1

To hang a picture frame right where you want it, make a guide for your nail. Tape over the head of a thumbtack or stick the head on double-faced tape right under the picture's mounting bracket. Hold the picture in place and push on the frame until the tack's point pricks the wall. Now you have a tiny mark to show you where to place your hanging nail.

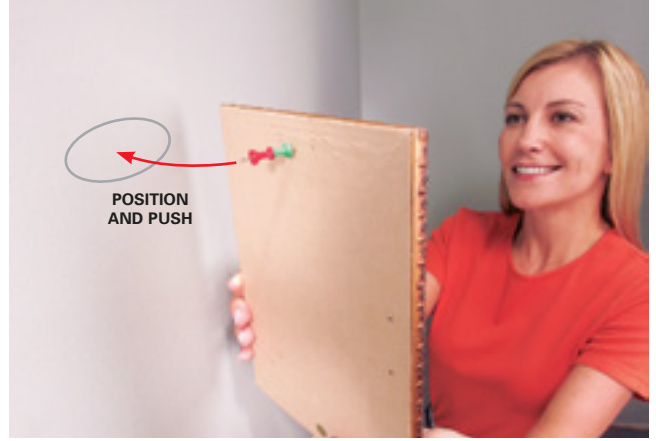

## Photo positioning tip 2

Here's a nifty way to mark nail hole positions on walls when you're hanging that new picture. Glue two pushpins top to top with a cyanoacrylate glue (such as Super Glue). Find the center of the picture along the upper back edge of the frame and press in one of the pins. Now just hold the picture up, maneuver it to the best spot, and press in to mark for the nail. This tip works best when you're hanging pictures with hardware screwed on the back of the frame, but if you're putting up wire-hung pictures, just measure the distance from the top of the wire to the pushpin hole and move the nail down that distance.

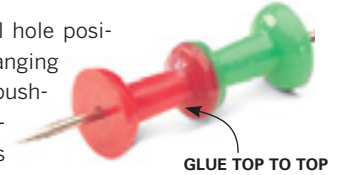

## Silence creaking pipes

Running hot water can cause copper pipes to expand and grind against pipe hangers and joists. So pick up some adhesive-backed felt at the hardware store and cut it into strips. Then remove each hanger and wrap the pipe before refastening the hanger.



## 15 solutions for cold rooms

- 1 Open the register.
- 2 Change furnace filter and check for dirty air-conditioning coil with flashlight; call a pro to clean the coil.
- 3 Add plastic deflector (\$5 at home centers or heating supply dealers) and rearrange furniture.
- 4 Adjust dampers for higher airflow.
- 5 Close registers around thermostat; use thermometer to compare room temperatures.
- 6 Install larger ducts where possible; add more runs if possible.
- 7 Undercut door 3/4 in. or add louvers; adding new return ducts is difficult.
- 8 Caulk and weather strip windows or replace with tighter, higher-efficiency units.
- 9 Increase heat flow if possible; add supplemental heat (gas fireplace, electric).
- 10 Increase attic and wall insulation if possible.
- 11 Insulate floor if crawl space is vented, or insulate crawl space perimeter and ground if closed off.
- 12 Insulate rim joists in basement; add more registers in basement.
- 13 Install attic vent chutes.
- 14 Seal leaks to attic at plumbing stacks, around lights and chimneys with fire-resistant sealant.
- 15 Increase heat flow, add supplemental heat or encourage better mixing with ceiling fan.

## Easier way to move boxes

If there's nowhere to grab it, moving a box can be awkward and put needless strain on your back. To make the task easier, cut a "V" in each end of the box and fold it in to make box handles.



## Quiet loud sinks

Fill the space between two stainless steel sink basins with expanding foam. The foam deadens vibrations and lessens the gong effect. It's possible to do this with the sink in place but much neater and easier before installation. Either way, let the foam harden and then trim away the excess with a knife.

## Dry doormat

Is your doormat squishy and virtually useless after a rainstorm? With a fine-tooth handsaw or a jigsaw, cut a piece of 2 x 4-ft. suspended ceiling plastic grid (from a home center) to fit under your mat. Air will circulate better under the elevated mat and help it dry faster and prevent mold from growing in the fabric. The plastic grid is sturdy and won't break even under the heftiest footstep.



## Perfect keyhole template

When you're installing a wall hanging that has keyhole slots on the back, create a template to help you position the wall screws. Lay a piece of paper over the slots and do a pencil rubbing à la Sherlock Holmes. Level and tape the guide to the wall. Mark the top of the keyholes with a nail and your screws will be in perfect position.

# Prevent bathroom mold

Eliminating bathroom dampness is the key to keeping mold from growing. To do that, follow these steps:

First, after a bath or a shower, squeeze water off the shower walls. That eliminates at least three-fourths of the moisture that supports mold and mildew growth.

Second, run your bath fans during your bath or shower and for a half hour after to flush out moisture. Or add a timer switch to make this step automatic.

Third, if you have tile, seal the grout lines annually with a standard grout sealer to waterproof them.

To get rid of current mold, scrub with detergent and water, then let the surface dry completely. Or use a solution of 10 percent bleach and 90 percent water (a stronger bleach solution will not give better results). Spray or brush on the solution, let it sit 10 minutes, then rinse it off and let dry.

If the fans aren't clearing out most of the moisture in your bathrooms after five to 10 minutes, your fans may not be moving enough air. Fans are certified by the volume (cfm, or cubic feet per minute) of air "exhausted" out of the room. To find the recommended fan capacity for your bathroom, simply multiply the bathroom square footage by 1.1 (assuming an 8-ft. ceiling; for a 9-ft. ceiling, multiply by 1.5).

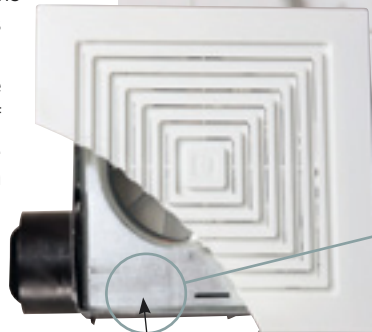

FAN LABEL



FAN VOLUME  
(CUBIC FEET PER MINUTE)



## Zip-tie your decorations

Zip ties are a simple way to string holiday lights on banisters and fences without marring the railing with nail marks. You'll find them in the electrical supplies aisle at home centers. After the holidays, snip the ties off with scissors.

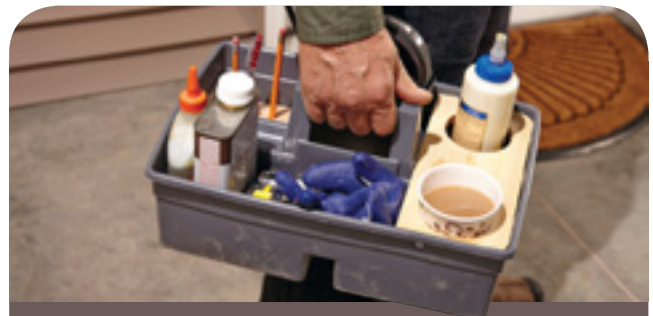

## Customized tote

Buy a cheap plastic tote in the tool storage area at a home center and modify it for your needs. For example, make a small plywood deck, drill 3-in. holes for coffee cups or glue bottles and fasten it to the tote. Another piece of plywood could have holes to keep pencils organized. Customize totes for various chores such as painting or gardening.

## 7 tips for avoiding knee pain while gardening

According to a survey released by the National Council on Aging, 38 percent of those suffering from osteoarthritis are hindered from gardening because of their condition.

Here are seven surefire ways to maintain healthy knees and keep your garden in shape:

**1 Get moving.** Motion reduces the risk for osteoarthritis. It both lubricates and nourishes knees.

**2 Warm up, then stretch.** Break a light sweat, then stretch to help maintain mobility and reduce joint stiffness.

**3 Get cushioned.** Wear supportive sneakers to take stress off the knees.

**4 Get strong.** Do leg lifts and exercises that strengthen quadriceps (front thigh muscles). They protect knees from damage caused by constant bending.

**5 Drink plenty of water.** Being dehydrated reduces flexibility and increases wear and tear. While gardening, people need substantially more to balance fluid loss.

**6 Don't push it.** A little discomfort may occur and will lessen after regular activity. But watch for "bad" pain. Stop if the pain is severe or sharp or causes you to limp.

**7 Chill out.** Ice knees for 15 minutes after gardening tasks if you tend to develop soreness.

## Fluff up furniture dents in your carpet

To remove furniture footprints from carpet, dampen the carpet with a white rag (colored fabric can leave dye in the carpet). Then heat the area with a hair dryer as you rake the carpet yarn gently in all directions with a spoon. In most cases, the crater will completely disappear in five minutes or less. If not, let the carpet dry completely and repeat the process.



## Drain vacuum

When a hard object like a toothbrush, comb or toy plugs a toilet or drain, a plunger may not be the solution—it might only push the obstruction in deeper. Instead, suck out the water and the obstruction with a wet/dry shop vacuum.





## Stop washing machine walk

If your washing machine has been making loud thumping noises and moving across the floor when it's in spin cycle, it probably needs to be leveled. Fortunately, it's an easy fix, though you may need a helper to tilt the machine.

Push the machine back into position if it has moved across the floor. Adjust the front legs to make the machine level across the front and from front to back (Photo 1). The legs can usually be turned by hand after the locking nut at the top of the threads is turned down, but if the threads are rusted, use a wrench.

After leveling, lock the leg into place with the locking nut (Photo 2).

Most washing machines have self-adjusting rear legs that level from side to side, but dirt, lint and rust may keep them from working properly. If the back isn't level, tip the washing machine up a few inches and then set it back down so the weight of the machine loosens the legs. If the machine still doesn't level out, the self-leveling support may be rusted against the washing machine frame. Tip the machine off the ground, then break the self-leveling support loose by tapping the legs (Photo 3).



**1** Lift the machine slightly with a pry bar to take the weight off the front legs, then turn the legs until the side of the washer is plumb.



**2** Tighten the locking nut up against the frame of the washing machine to keep the leg from turning.



**3** If the rear leveling mechanism is frozen with rust, tap the legs a few times with pliers or a hammer to break it free.

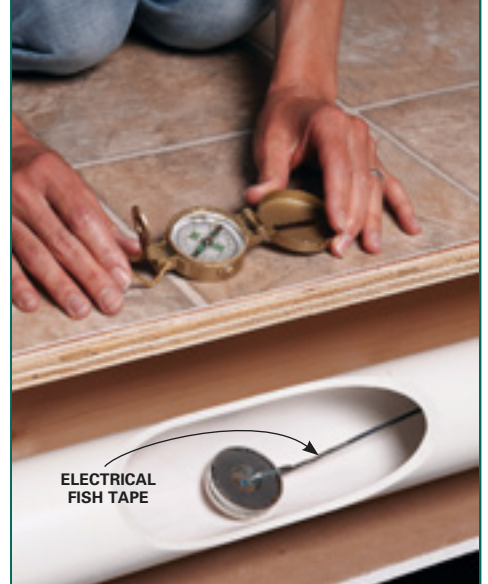

## Pipe orienteering

When trying to locate a pipe under the floor, attach a rare earth (neodymium) magnet to an electrical fish tape and feed it into drain lines through the cleanout plug. Locate the magnet (and the pipe) under the floor using an ordinary compass, which will turn wildly when it finds the strong magnet.



## Pet collar cord hanger

Collars for dogs and cats make great straps to keep electrical cords organized in the shop, and work well for air hoses too. The leash ring is perfect for hanging the cords on the hooks, and the quick-release fastener makes for fast strapping and unstrapping.

## Bucket flush

You don't have to run to the neighbor's bathroom during a plumbing project. Before you turn off the water supply, fill 2-gallon buckets with water. Flush the toilet by dumping the water in the bowl. You'll get one flush per bucket. Works just as well as the usual method, although it won't refill the bowl.



## Stadium-seating bookshelf

Cut a hollow PVC fence post to the length of your bookshelf and push it to the back of the shelf. This creates a second tier for paperback storage, doubling the number of books you can put on display.

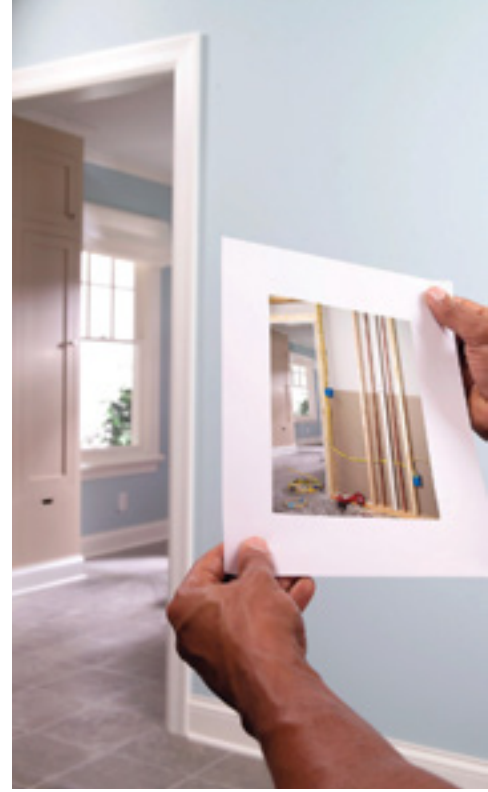
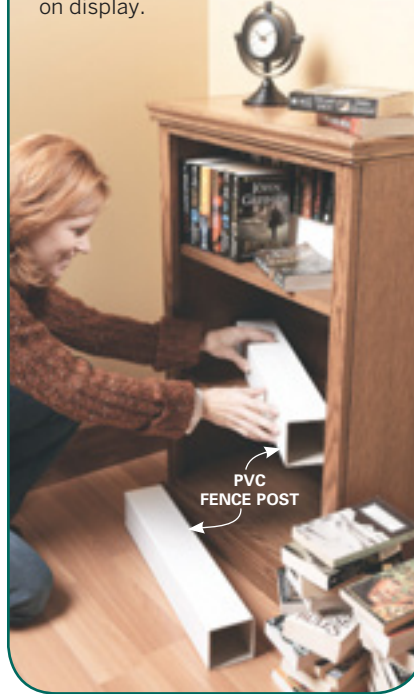

## Next best thing to X-ray vision

Your walls may not have much inner beauty, but it's a good idea to take pictures of what's inside during remodeling. The same goes for floors and ceilings. When your next remodeling or repair project rolls around, you'll know where the framing and the electrical and plumbing lines are.

## 3 uses for dry lubricants

Penetrating spray lubricant is not always the best lubricant for everything around the house. Drawers, cabinets, locks and latches, windows, sliding and bifold doors, and other metal, wood and plastic surfaces inside the house all need lubricants that stay dry and clean.

Graphite (powder or spray), wax and silicone all dry quickly, so they don't attract dust, which can clog or gum up moving parts. Each of them solves unique lubricating problems better than any other lubricant, making them well worth keeping in the shop next to the penetrating spray.



Use graphite to lubricate locks; unlike oil or penetrating sprays, it won't collect dust, which will clog the mechanism.



Rub a solid lubricant made from wax on wood drawers, wood windows and other porous surfaces.



Use silicone spray on drawer rollers, window tracks and other plastic, rubber and metal surfaces. It dries almost instantly.

## Rolling records

Write down important car information right where you need it—under your hood—with a paint pen. Mileage and dates for coolant, air filter and tire changes will never get lost again.



## Bumper sticker release

Heat from a hair dryer softens adhesive, making bumper stickers, price tags and other labels easy to pull off. Start at one corner and pull slowly, allowing the heat to loosen the sticker.



## Empty the trap

Before you remove a sink trap, give the drain a few plunges with a toilet plunger. This will push most of the water out of the trap, lessening the mess when you pull the trap. If you have a double sink, be sure to plug the other drain to contain the air pressure. If the strainer isn't a screw-down style, you'll have to hold it down while you plunge the drain.



## Stop losing socks

Stuff a strip of foam pipe insulation into the space between your washer and your dryer or along the wall. That way, socks can't slip into the abyss.



# 5 things to check before a road trip

It's time for the beloved family road trip and everybody's itching to get going. Better do a quick check of your car's health first. Some discoveries can prevent "towable" experiences; others are safety issues. It would be best to run through this five-minute checklist a week ahead of departure so you'll have time to get the car repaired if a mechanic is needed.



**1 Check the condition of all belts.** Broken belts are one of the most common reasons for roadside assistance calls. Replacement belts are easy to locate and replace near your home. But the belt for your car may be tough to find in rural areas. Twist the belt slightly to expose cracks or glazing. Replace any belt that is cracked, worn or delaminating.



**2 Check for fluid leaks.** Small leaks often turn into gushers once you leave town, and that can be costly. The most common sources are the radiator, engine oil pan, transmission oil pan and hoses, power steering hoses, steering rack, and heater and radiator hoses. Use a flashlight to check for leaks. Note the color of the fluid and trace the fluid trails back to their source.

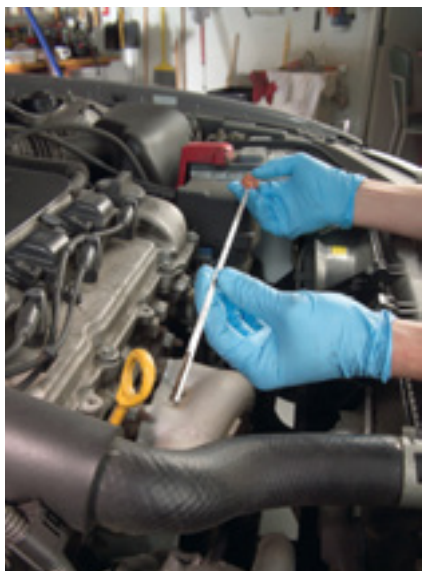

**3 Check and top off all fluids.** With the engine off, check power steering, brake and windshield washer fluid, coolant, and engine oil. Most automatic transmissions must be checked with the engine hot and running and the gearshift in "park." Check your owner's manual to confirm. Look for the power steering fluid level to reach the COLD mark on the dipstick. If it's low, check your owner's manual and buy the right fluid for your vehicle.



**4 Check all exterior lights.** They're easy to check, and inexpensive to replace. Bulb numbers and replacement procedures are listed in your owner's manual. Turn the key to the "accessories" position (there's no need to start the engine). Operate the turn signals, brake lights and backup lights, and check for reflections in your rearview mirror. Perform the same checks on the front turn signal lights, headlights, high beams and running lights.



**5 Check the tire pressure.** Low tire air pressure causes engines to burn more gas and tires to wear faster and run hotter. Hot tires are more prone to blowout during extended highway drives. Check them all (including the spare) before you leave town. Look for the correct air pressure on the decal located on either the driver's door or the door pillar or check your owner's manual. Make sure the tires are cold when you check tire pressure.



## Propane tank carrier

When you take your 20-lb. propane tank to be filled, it probably rolls around in the trunk of your car. To solve the problem, stick it in an old milk crate. The crate's wide, flat base keeps the tank stable.

## No-scratch chair rockers

To protect your wood floors, glue strips of bicycle inner tube to rocking chair rockers with contact cement. Cut the strips with scissors. When gluing them, apply masking tape to the sides of the rockers to minimize cleanup.



## Drip detector

Lay a couple of white cardboard boxes end-to-end on your garage floor where you park your car. Not only will doing so protect your floor from stains, but you'll be able to identify which fluid is leaking by its color and location on the white surface.

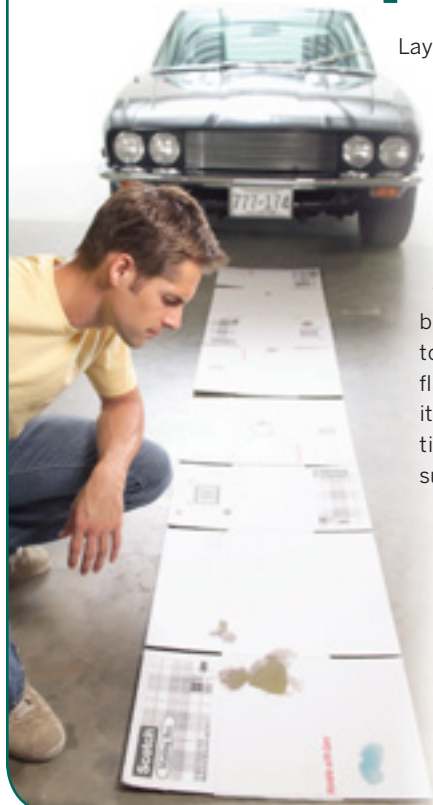

## 5-gallon bucket spacer

It's nice to keep some empty 5-gallon buckets around, but the only way to efficiently store them is to stack them. The problem is, they can get stuck so tight it feels like they're glued together. Put a short chunk of 2x4 between the buckets when you stack them. It'll be a cinch to pull them apart.

## Inside view

Whether you're remodeling or just running wire, knowing what's inside the walls is helpful. If your project requires holes in the wall or ceiling, all you need is a camera or cell phone to see what's inside those dark spaces.



## Hardware store helper

A digital camera or cell phone helps you get the right plumbing supplies at the hardware store or home center. Snap a few pictures and take them with you. It's faster than making a list, and the images are more reliable than your memory.



## No-mess oil spout

To avoid the inevitable mess when you tip that oil bottle into the fill tube of your car or lawn mower, use the squirt cap from a bottle of water. They screw onto most 1-qt. oil containers perfectly.

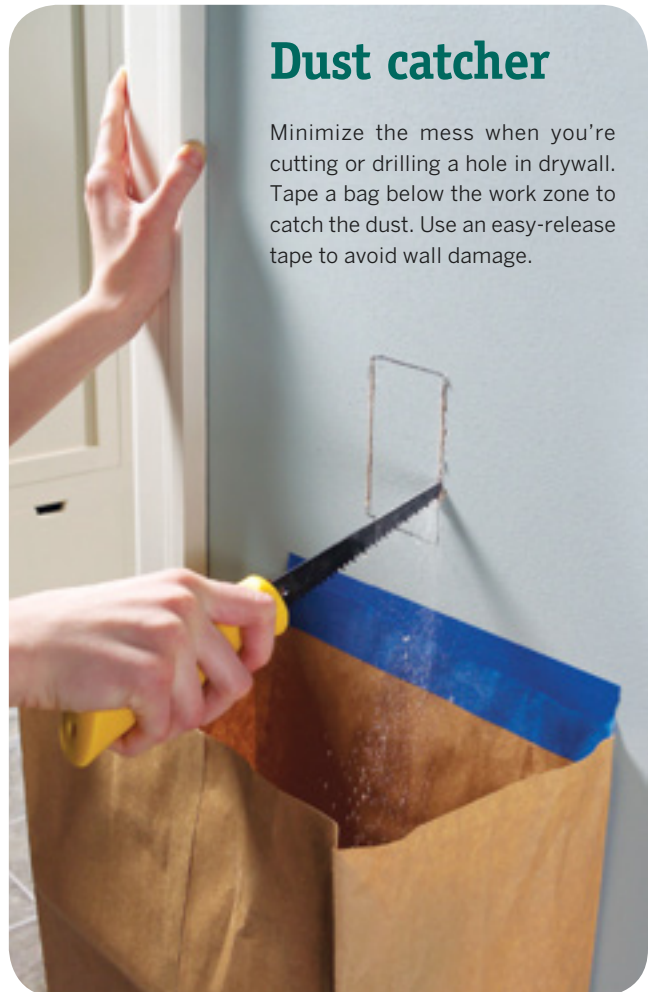

## Dust catcher

Minimize the mess when you're cutting or drilling a hole in drywall. Tape a bag below the work zone to catch the dust. Use an easy-release tape to avoid wall damage.

# Special section: Cut kitchen & bath chores

## Microwave cleaner

It's easy to clean baked-on food and spills from your microwave! Partially fill a measuring or coffee cup with water and add a slice of lemon. Boil the water for a minute, and then leave the door closed and let the steam loosen the mess. After 10 minutes, open the door and wipe away the grime.



## Under-cabinet cleanup

When the floor of your sink cabinet needs a spruce-up, lay down squares of self-adhesive vinyl tile. They're inexpensive and provide an easy-to-wipe-clean surface.

## Sparkling dishwasher

Add a cup of vinegar to your empty dishwasher and let it run a full cycle once a month or so. Your kitchen may smell a bit like a pickle jar for a few hours, but hard-water lime buildup will be rinsed away, making your spray arm and other dishwasher parts work flawlessly.



# 10 time-saving grilling tips

- 1 Think about the whole meal.** Before you grill or even grocery shop, envision the *whole* meal (sides, sauces ... even dessert). Then make a list. That way, you make only one trip to the market.
- 2 Let the grocery store be your sous-chef.** Let them chop, dice or shred ingredients; or breeze through the salad bar and put everything into containers. Use quality bottled or jarred products that are already pitted or sliced, too.
- 3 Go easy on yourself.** Here's a simple grilling technique ... put everything into individual foil packages. The packets can be prepared the night before and kept in the refrigerator until cooking. Boneless, skinless chicken breasts or fish fillets topped with chopped veggies are the ticket for no-mess, foil-packet grilling.
- 4 Eat healthy.** Aim for three servings of fruits and/or vegetables with your evening meal. After all, who knows what your family has eaten for lunch? Incorporating fruits and veggies in the evening meal is easy to do if you grill meat and a vegetable, include a vegetable- or fruit-based sauce and add a simple salad or fresh fruit. For a big gold star, include a whole-grain dish, such as brown rice, polenta or whole-grain bread.
- 5 Befriend olive oil.** Brush foods with olive oil, then season with salt and pepper before grilling. The foods are less likely to stick, making grilling less muss and fuss.
- 6 Become "tray chic."** Stack two baking sheets, setting your ingredients on the top sheet. Once your food is on the grill, move the clean sheet to the top so you have a place to put the cooked food. This method saves time because you don't have to run back to the kitchen to fetch a missing ingredient or clean platter.
- 7 Preheat your grill** to the proper temperature *before* you start cooking. Check the grill's temperature by holding your hand 3 to 4 in. above the grate. If you can keep it there for 2 seconds, it's a hot fire; 4 seconds, a medium-hot fire; and 5 seconds, a medium-low fire.
- 8 Make sauces function as vegetables.** Why do two things when you can combine them into one? Like the mother who told her kids they weren't eating "yucky" tuna fish, they were eating "Chicken of the Sea," you can tell yours, "This isn't just a vegetable ... it's salsa. *Olé!*"
- 9 Grill for leftovers.** Get two meals out of one effort, to use in tomorrow's lunches or dinners. Leftover grilled goodies are delicious in salads, sandwiches and pastas. Grill once to eat twice, and you can put your feet up the next day and read that magazine you never have time to read because dinner's ready already!
- 10 Chill at the grill!** Sip a glass of lemonade or iced tea, soak up that gorgeous sunset and smell the delicious aroma of the grilled food bound for your table. Life is good.

## 6 nontoxic bug blasters for the kitchen

You can make your kitchen a no-fly zone for insect pests with nontoxic repellents and traps that you can make from everyday kitchen items.

- 1 To get rid of fruit flies** hovering in the kitchen, get out a fine-misting spray bottle and fill it with rubbing alcohol. Spraying the little flies knocks them out and makes them fall to the floor, where you can sweep them up.
- 2 Make your own pest strips** by covering empty paper-towel or toilet-paper rolls with transparent tape, sticky side out. Hang them in the kitchen or wherever you need them.
- 3 To ant-proof your kitchen,** give it the lemon treatment. First squirt some lemon juice on door thresholds and windowsills. Then squeeze lemon juice into any holes or cracks where the ants are getting in. Finally, scatter small slices of lemon peel around the outdoor entrance. The ants will get the message that they aren't welcome.
- 4 Keep your kitchen free of flies** with a homemade flytrap that uses no toxic chemicals. In a small saucepan, simmer 2 cups of milk, 1/4 pound of raw sugar, and 2 ounces of ground pepper for about 10 minutes, stirring occasionally. Pour into shallow dishes or bowls and set them around the kitchen, patio, or anywhere the flies are a problem. The pestiferous bugs will flock to the bowls and drown!
- 5 For roaches and fleas,** lemons are also effective. Simply mix the juice of four lemons (along with the rinds) with 1/2 gallon of water and wash your floors with it; then watch the fleas and roaches flee. They hate the smell.
- 6 If you have roaches,** don't call an exterminator to spray noxious pesticides. Instead, scatter a mixture of equal parts sugar and baking powder over the infested area. The sugar will attract the roaches, and the baking powder will kill them. Replace it frequently with a fresh mixture to prevent future infestations.



## Synthetic soap simplifies bathroom cleaning

In terms of chemistry, some soaps aren't really true soap. Any soap in a liquid or gel form and some bar soaps, such as Zest and Ivory, are synthetic soap. These non-soap soaps are much less likely to form that dreaded layer of tough scum on your sink or tub.



### Fur filter

If you wash your dog in the bathtub or shower, you're begging for a clogged drain. Keep fur out of the drain with a mesh-type scrubbing pad. In a shower, clip the pad to the drain plate with a bobby pin. In a bathtub, wedge two pads under the stopper from two sides. The pads catch fur but let water flow through.



### Sharpen dull edges with a coffee mug

In a pinch, you can sharpen a dull blade by flipping over a ceramic mug and using the unglazed ring around the bottom as an instant ceramic sharpening stone. You won't be able to shave with the blade, but it'll be good enough for most other tasks.

### Countertop gap filler

If crumbs, papers or even flatware falls into the gap between your countertop and refrigerator, fill the void with nearly invisible plastic tubing. Clear tubing is available at home centers in several widths starting at 1/8 in.





# 7

## Clean (almost) anything



If you're looking for ways to simplify cleaning or get rid of stubborn stains, you'll find everything you need on the following pages. This chapter is loaded with more than 40 tips for around-the-house cleaning and even features a tip for quickly finding parts that you drop and lose on the floor.

## Find lost parts

Here's a slick way to locate small parts that fall to the floor. Turn off the lights and shine a flashlight beam across the floor. When the part is struck by the light, its large shadow makes it easy to find.



## Remove tree sap from vinyl siding

If drippy trees or deck lumber deposit sap on your vinyl siding, don't delay cleanup. The longer you wait, the more stubborn the sap will become. If you attack the fresh sap within a week or so, a common kitchen cleaner such as Formula 409 or Fantastik will likely remove the goo. You can also use a biodegradable product such as Simple Green. If standard cleaners won't dissolve the sap, use a citrus cleaner such as Goo Gone. Check the label of any product you use to make sure it's recommended for vinyl and test it in an inconspicuous spot for discoloration. Apply the cleaner with a rag or sponge. Scrub tough spots with a soft-bristle brush.

## Clean dirty, greasy, gummy surfaces

The results of a simple surface cleaning with mineral spirits may amaze you. Polish buildup and the dirt embedded in it can muddy the finish, but will wipe away. Don't use stronger solvents; they might dissolve the finish.

- 1** Soak a coarse, absorbent, clean cloth with mineral spirits and wipe the finish. Keep applying and wiping until the cloth no longer picks up dirt. Then do a final wipe with a fresh, clean rag.



- 2** Clean crevices, grooves and carved areas with cotton swabs dipped in mineral spirits.



## Sparkling windows in 30 seconds



Just scrub, squeegee and wipe!



## Nylon scrubber

Put your car-washing sponge inside a pair of old pantyhose for a non-abrasive, paint-friendly scrubber. The threads act like thousands of little scrapers that rub off insects and gunk with every swipe.



## Duster for the vertically challenged

Dusting ceiling fans and other high, out-of-reach objects is a real chore. To make it easier, wrap a dryer sheet around a clean paint roller and secure the ends with rubber bands. Attach an extension handle to the roller and dust away.

# 12 ways to clean with vinegar

## Clean window blinds

Give your mini-blinds or venetians “the white glove treatment.” Put on a white cotton glove and moisten the fingers in a solution of equal parts white vinegar and hot tap water. Slide your fingers across both sides of each slat to quickly clean them. Periodically rinse the glove in a container of clean water.

## Get rid of smoke odor

Remove the lingering odor of burned food or cigarettes by setting out shallow bowls about three-quarters full of white or cider vinegar. The odor should be gone in less than a day. To quickly banish the smell of fresh cigarette smoke, moisten a cloth with vinegar and wave it around a bit.

## Erase ballpoint-pen marks

Dab some full-strength white vinegar onto the marks, using a sponge. Repeat until the marks are gone.

## Restore rugs

Bring a rug or carpet back to life by brushing it with a clean push broom dipped in a solution of 1 cup white vinegar in 1 gallon water. The faded threads will perk up, and you don't even need to rinse off the solution.

## Keep rugs from mildewing

To prevent mildew from forming on the bottoms of carpets and rugs, mist the backs with full-strength white vinegar from a spray bottle.

## Revitalize wood paneling

To liven up dull wood paneling, mix 2 cups warm water, 4 tablespoons white or cider vinegar, and 2 tablespoons olive oil in a container, give it a couple of shakes, and apply with a clean cloth. Let it soak in for several minutes, then polish with a dry cloth.

## Brighten up brickwork

To clean brick floors without breaking out the polish, just go over them with a damp mop dipped in 1 cup white vinegar mixed with 1 gallon warm water. Brighten fireplace bricks the same way.

## Wipe away mildew

To remove mildew stains, reach for white vinegar. It can be safely used without additional ventilation and can be applied to almost any surface—bathroom fixtures and tile, clothing, furniture, painted surfaces, plastic curtains and more. For heavy mildew accumulations, use it full strength. For light stains, dilute it with an equal amount of water.

## Unglue stickers, decals and price tags

To remove a sticker or decal on painted furniture or a painted wall, saturate the corners and sides of the sticker with full-strength white vinegar and carefully scrape it off, using an expired credit card. Remove any residue by pouring on a bit more vinegar. Let it sit for a minute or two, then wipe with a clean cloth. This is equally effective for removing price tags and other stickers from glass, plastic and other glossy surfaces.

## Clean piano keys

To get grimy fingerprints and stains off piano keys, dip a soft cloth into a solution of 1/2 cup white vinegar mixed with 2 cups water, squeeze it out thoroughly, then gently wipe each key. Use a second cloth to dry each key as you move along. Let the keyboard dry uncovered for 24 hours.

## Freshen a musty closet

Got a closet that doesn't smell fresh? Empty it, then wash the walls, ceiling, and floor with a cloth dampened in a solution of 1 cup vinegar, 1 cup ammonia, and 1/4 cup baking soda in 1 gallon water. Let the interior dry with the door open before refilling it.

## Remove carpet stains

You can lift out many stains from your carpet with vinegar.

- Rub light carpet stains with a mixture of 2 tablespoons salt dissolved in 1/2 cup white vinegar. Let dry, then vacuum.
- For larger or darker stains, add 2 tablespoons borax to the mixture and use in the same way.
- For tough, ground-in dirt and other stains, make a paste of 1 tablespoon vinegar with 1 tablespoon cornstarch, and rub on with a dry cloth. Let it sit for two days, then vacuum.

## Easier bottle cleaning

Clean those narrow-necked jars and vases with small gravel (aquarium gravel works the best). Fill one-third of the jar with water. Add a handful of gravel, and then stir and shake the jar. The gravel will scour the inside of the jar clean. Dump the gravel into a strainer, give it a quick rinse (so it doesn't stink!) and save it for next time.





MICROFIBER DUSTING GLOVE

## Clean faster, easier and better

Microfibers are tiny strands (usually less than one-tenth the thickness of a human hair) that are sliced into even smaller strands and then woven into fabric. Those tiny strands reach into crevices and provide millions of little pockets within the fabric to hold dirt particles. The strands also have sharp scouring edges, so microfiber cloths often clean effectively without chemicals or even water (you can use cleansers or water if you choose). When used dry, microfiber cloths generate static electricity, which attracts and holds dust. To clean out all that dirt, just toss microfiber items in the washing machine. You can use microfiber products to dust furniture, clean glass, mop floors



MICROFIBER CLEANING GEAR

and even wash your car—or anything else. Find microfiber dust cloths, mops and other cleaning gear at most discount stores.



WRAPPING PAPER ROLL

## Vacuum extension tube

Don't throw away the cardboard tube from wrapping paper! Tape the tube to the end of a vacuum cleaner wand to reach cobwebs in ceiling corners or dust on fans. Reach all the way under beds and furniture, or flatten the roll to vacuum narrow crevices. Make it a permanent dusting wand by wrapping it with duct tape, and it'll stand up to years of use.

## Take out the ring without refinishing

Spilled water or a wet glass can leave a white stain on wood furniture. Often, the only solution is to completely strip and refinish the piece. But there are two solvents that can sometimes remove water marks in a few minutes without harming the finish. Both solvents give off nasty fumes, so work outside in a well-ventilated area. If you think the piece might be especially old or valuable, consult an antiques dealer before trying these remedies.

First, rub the stain with a soft rag dipped in mineral spirits. If the original finish has a coating of wax over it, there's a good chance that only the wax has turned white. Mineral spirits removes wax without harming the underlying finish. Have patience; the mineral spirits may take a few minutes to soften the wax. If the stain disappears but the rubbed area looks dull, clean the entire surface with mineral spirits and apply a new coat of furniture wax.

If mineral spirits doesn't work, gently wipe the stain using a soft rag lightly dampened with denatured alcohol. Alcohol can damage some finishes, so test it on an inconspicuous spot first. Stop every minute or so to examine the finish to make sure you're not damaging it. Again, have patience. Sometimes alcohol can draw out moisture that's trapped in the finish, but it works slowly. If you don't see any results after five minutes, refinishing is the only way to remove the mark.



## Scuff mark eraser

Clean off shoe scuff marks from vinyl flooring with a clean, dry tennis ball. A light rub and heel marks are "erased."



## Easier grout haze cleanup

The thousands of microscopic fabric hooks on a microfiber cloth make it perfect to cut through the dried grout haze left after a tiling project. You'll still have to rinse and repeat, but the haze will clean up faster than it would with an ordinary rag.

## 3 easy ideas for clean birdbaths



- To clean your birdbath, put two cups of vinegar in the bath and fill it to the brim with water. Cover with a trash-can lid, and let the bath soak overnight. Scrub and rinse well.
- To attract butterflies to your birdbath and avoid algae, put a layer of builder's sand in the bottom of the birdbath.
- Add a pantyhose leg stuffed with oat straw to your water for an algae-free birdbath.

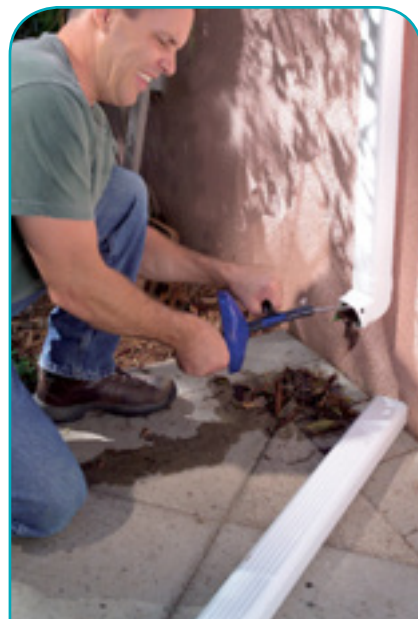

## Snake out spouts

Your plumber's snake is a great tool for pulling clumps of wet leaves out of clogged downspouts.



## Power scour

Now that discount and dollar stores carry cheap electric toothbrushes, you can add a modern twist to routine cleaning. Rapid vibration will quickly scrub out stubborn dirt, while the long handle can get to hard-to-reach places without all the elbow grease.

## Quick cleanup cat litter

Cut your litter cleanup time in half with this nifty trick! Line your litter pan with a plastic kitchen garbage bag before adding the litter. When it's time to change the litter, simply lift out the bag, tie it off and throw it all away.



# 8 quick fixes for carpet stains

Carpet stains can really drive you crazy. No worries. Depending on the type of stain, one of these unexpectedly handy products may supply an instant solution. With any of the techniques listed, repeat as needed until the stain is gone.

**Ammonia** Sponge the stain with a mixture of 1/2 cup of clear ammonia and 4 cups of warm water. Let dry thoroughly, and repeat if needed.

**Baby wipes** For a fresh spill of almost any kind, grab a baby wipe and start blotting; this also works for stains on upholstery or clothing.

**Baking soda** To get rid of grease or wine stains, blot up as much of the stain as possible with a paper towel, then sprinkle a liberal amount of baking soda over the spot. Give the baking soda at least an hour to absorb the stain, then vacuum up the remaining powder.

**Beer** Pour a little beer on top of the carpet stain, rub it lightly into the material, and the stain should disappear.

**Borax** Another great carpet stain remover is borax. Thoroughly wet the stained area, then rub in some borax. Let the area dry, then vacuum or blot it with a solution of equal parts vinegar and soapy water, and let dry again.

**Cornstarch and milk** If you're attacking an ink stain on your carpet, mix a little milk with some cornstarch to make a paste. Apply the paste to the ink stain and let it dry for a few hours. Then brush the mixture to loosen it and just vacuum it up.

**Shaving cream** Blot up what you can of spills, pat with a wet sponge, then squirt shaving cream on the spot. Wipe clean with a damp sponge. Works on clothes, too!

**White wine and salt** Remove red wine stains by pouring a little white wine on top, then sponging with cold water. Now sprinkle the area with salt and wait about 10 minutes before vacuuming.

## Remove stains from vinyl flooring

Sheet vinyl "resilient" flooring is so easy to clean that it may never require anything beyond damp mopping with a cleaner intended for vinyl floors. But if your floor has marks or stains that still won't come off, you can use stronger stuff. Although the methods described here won't harm most vinyl floors, test them in a closet or on a section of flooring that's hidden by furniture. Use white rags only; chemicals that dissolve stains can also make fabric colors bleed and stain your floor.

**Isopropyl alcohol**, sold as a disinfectant at discount stores, is a mild solvent. It's the best cleaner for heel marks and works on other tough stains too. You can also use lighter fluid or mineral spirits. Remember that all these products are flammable; turn off any nearby pilot lights and hang rags out to dry before throwing them away.

**Bleach** will often erase stains left by liquids like fruit juices, tomato sauce and wine. Mix one part household bleach with four parts water, soak a rag in it and lay the rag over the stain. Bleach works slowly; you may have to leave the rag in place for an hour or so.

**Oxalic acid** is the solution for stubborn rust stains. It's often labeled "wood bleach"—but not all wood bleach contains oxalic acid, so check the label. Most paint stores and some hardware stores carry oxalic acid. If the stain won't rub off, wet a rag with the acid solution and lay it over the stain for 10 minutes. If the stain remains, rewet the rag and repeat. When that's done, rinse the floor with clean water.

**1** Dampen a white rag with isopropyl alcohol and rub away heel marks.



**2** Mix oxalic acid powder with water and dab rust stains to remove them. Protect your hands with rubber gloves and open a window for ventilation.





## Remove pet hair quickly

If you have a shedding pet, Sticky-Sheets can make cleaning up after it a lot easier. Just peel off the backing, press the sheet against the furniture, then pull it up. The hair sticks to the sheet, but the 24 x 36-in. sheets won't stick to each other, making application easier. The sheets can be reused up to three times.

The company claims that Americans spend more than 200 million hours cleaning up more than 25,000 tons of pet hair each year. If that's true, then StickySheets can save a lot of time. Buy them directly from the manufacturer.

**StickySheets Unlimited**



## Clean a vent hood grease filter

Vent hood grease filters are notoriously difficult to clean. The dishwasher yields disappointing results, and "grease cutting" household cleaners usually fall flat. Instead of these old stand-bys, go to the auto parts store and buy some water-based degreaser. Fill the sink with hot water and degreaser, drop in the filter and let the degreaser do all the work. The filter will come out sparkling clean in just a few minutes. Rinse it off and let it dry before reinstalling it.

## Clean the CD player lens

If your CD player skips or doesn't play at all, the laser lens is probably dirty. First, try another CD to make sure the player rather than the CD is the problem. Wipe the lens with a soft cloth to remove dust. If that doesn't work, dip a cotton swab in isopropyl alcohol. Blot the swab on a cloth to leave it damp but not dripping wet. Rub the lens with the swab. For lenses that aren't accessible, electronics stores sell lens-cleaning discs. However, these cleaners don't always solve the problem.



## Eliminate pet stains and odors

Several pet owners tell this story: Spot or Fluffy made a deposit on the rug or sofa, leaving a stubborn stain. And even if the stain was removed, the odor remained. After other cleaning products failed, they found success with “enzyme” cleaners.

Enzyme products are easy to use—just spray or blot them on the stain according to the directions. The products contain harmless bacteria that “eat” the organic matter that causes the odor. When the organic matter

is gone, the bacteria run out of food and die. The whole process will take anywhere from a few hours to a few days. Some manufacturers recommend covering the area with plastic or a wet cloth to keep the bacteria moist and healthy. Spray bottles of enzyme cleaner are available at pet and discount stores. Be sure to choose a product made specifically for pet stains.



## Grille duster

If the grille on your bathroom exhaust fan is clogged with dust, try a trick that’s faster and more effective than vacuuming: Turn on the fan and blast out the dust with “canned air.” The fan will blow the dust outside. This works on the return air grilles of your central heating/cooling system too. Run the system so that the return airflow will carry the dust to the filter. You’ll find canned air at home centers and hardware stores, usually in the electrical supplies aisle. **Caution:** The cans contain chemical propellants, not just air. Don’t let children play with the can.

## Clean a sluggish toilet

If your toilet flushes slowly, the rinse holes under the rim may be clogged with mineral deposits. With a mirror and a coat hanger, you can clean out those clogged holes without ever getting your hands dirty.

**Use a hand mirror to see the holes under the rim of the toilet. Bend a coat hanger flat and probe the tip into the holes to poke out any mineral deposits.**



# Special section: Extraordinary uses for ordinary things

## Spring clamp plan hold-down



If you like to use your workbench outside in nice weather, then you know that the slightest breeze sends your plans flying or turns the magazine page. To solve that problem, put spring clamps at the corners of the plans or magazine to keep it on the table and open to the desired page.

## Mini power washer



A garden sprayer can be a mini power washer for cleaning windowsills and other hard-to-reach spots. Before you fill the tank with water, be sure to rinse it repeatedly to flush out any chemical residue.

## Gutter cleaner

An old plastic spatula makes a great tool for cleaning debris from gutters. It doesn't scratch up the gutter, and you can cut it with snips to fit gutter contours. Grime wipes right off the spatula too, making cleanup a breeze.

PLASTIC SPATULA

## 8 uses for Alka-Seltzer

### Clean your coffeemaker

Fill your percolator or the water chamber of your drip coffeemaker with water and plop in four Alka-Seltzer tablets. When the Alka-Seltzer has dissolved, put the coffeemaker through a brew cycle to clean the tubes. Rinse the chamber out two or three times, then run a brew cycle with plain water before making coffee.

### Clean a vase

That stuck-on residue at the bottom of narrow-neck vases may seem impossible to scrub out, but you can easily bubble it away. Fill the vase halfway with water and drop in two Alka-Seltzer tablets. Wait until the fizzing stops, then rinse the vase clean. The same trick works for cleaning a glass-lined thermos.

### Clean glass cookware

Say so long to scouring those stubborn stains off your oven-proof glass cookware. Just fill the container with water, add up to six Alka-Seltzer tablets, and let it soak for an hour. The stains should easily scrub away.

### Clean your toilet

The citric acid in Alka-Seltzer combined with its fizzing action is an effective toilet bowl cleaner. Simply drop a couple of tablets into the bowl and find something else to do for 20 minutes or so. When you return, a few swipes with a toilet brush will leave your bowl gleaming.

### Clean jewelry

Drop your dull-looking jewelry in a glass of fizzing Alka-Seltzer for a couple of minutes. It will sparkle and shine when you pull it out.

### Unclog a drain

Drain clogged again? Get almost instant relief: Drop a couple of Alka-Seltzer tablets down the opening, then pour in a cup of vinegar. Wait a few minutes and then run the hot water at full force to clear the clog. This is also a good way to eliminate kitchen drain odors.

### Soothe insect bites

Mosquito or other insect bite driving you nuts? To ease the itch, drop two Alka-Seltzer tablets in half a glass of water. Dip a cotton ball in the glass and apply it to the bite. Caution: Don't do this if you are allergic to aspirin, which is a key ingredient in Alka-Seltzer.

### Attract fish

All avid anglers know fish are attracted to bubbles. If you are using a hollow plastic tube jig on your line, just break off a piece of Alka-Seltzer and slip it into the tube. The jig will produce an enticing stream of bubbles as it sinks.

## Garbage bag holder

Keep your garbage bag in place with sections of old garden hose. Cut four 9-in.-long pieces of hose, slit them lengthwise and place them over the garbage can rim.



## Corkscrew in a pinch

It's difficult to remember everything for that important date, like a corkscrew. But if you have your tools, you're in luck. Just drive a coarse-threaded deck screw into the cork, grab the screwhead with pliers, and carefully pull out the cork.



## 9 uses for milk

### Give yourself a facial

Here's a great way to give yourself a fancy spa facial at home. Make a mask by mixing 1/4 cup of powdered milk with enough water to form a thick paste. Thoroughly coat your face with the mixture, let dry completely, then rinse with warm water. Your face will feel fresh and rejuvenated.

### Soothe sunburn and bug bites

If your skin feels like it's burning up from too much sun exposure or if itchy bug bites are driving you crazy, try using a little milk paste for soothing relief. Mix one part powdered milk with two parts water and add a pinch or two of salt. Dab it on the burn or bite. The enzymes in the milk powder will help neutralize the insect-bite venom and help relieve sunburn pain.

### Impromptu makeup remover

When you run out of makeup remover and you can't get to the store, use powdered milk instead. Just mix 3 tablespoons of powdered milk with 1/3 cup of warm water in a jar and shake well. Add more water or powder as necessary to achieve the consistency of heavy cream. Now you are ready to apply your makeshift makeup remover with a facecloth. When you're done, wipe it off and rinse with water.

### Clean patent leather

Make your patent-leather purses or shoes look like new again. Just dab on a little milk, let it dry, and buff with a soft cloth.

### Soften skin

Treat yourself to a luxurious foamy milk bath. Toss 1/2 cup or so of powdered milk into the tub as it fills. Milk acts as a natural skin softener.

### Clean and soften dirty hands

Gardening often results in stained and gritty hands. Regular soap just won't do, but this will: Make a paste of oatmeal and milk and rub it vigorously on your hands. The stains will be gone and the oatmeal-and-milk mixture will soften and soothe your skin.

### Remove ink stains from clothes

To remove ink stains from colored clothes, an overnight milk bath will often do the trick. Just soak the affected garment in milk overnight and launder as usual the next day.

### Boost corn-on-the-cob flavor

Here's a simple way to make corn on the cob taste sweeter and fresher. Just add 1/4 cup of powdered milk to the pot of boiling water before you toss in the corn.

### Make frozen fish taste fresh

If you want fish from your freezer to taste like it was fresh caught, try this trick: Place the frozen fish in a bath of milk until it thaws. The milk will make it taste fresher.

# 10 uses for wire coat hangers

## Stop caulk-tube ooze

To prevent caulk from oozing from the tube once the job is done, cut a 3-in. piece of coat hanger wire; shape one end into a hook and insert the straight end into the tube. Now you can easily pull out the stopper as needed.

## Secure a soldering iron

Keeping a hot soldering iron from rolling away and burning something on your workbench is a real problem. To solve this, just twist a wire coat hanger into a holder for the iron to rest in. To make the holder, simply bend an ordinary coat hanger in half to form a large V. Then bend each half in half so that the entire piece is shaped like a W.

## Extend your reach

Can't reach that utensil that has fallen behind the refrigerator or stove? Try straightening a wire coat hanger (except for the hook at the end), and use it to fish for the object.

## Make a giant bubble wand

Kids will love to make giant bubbles with a homemade bubble wand fashioned from a wire coat hanger. Shape the hanger into a hoop with a handle and dip it into a bucket filled with 1 part liquid dishwashing detergent in 2 parts water. Add a few drops of food coloring to make the bubbles more visible.

## Create arts and crafts

Make mobiles for the kids' room using wire coat hangers; paint them in bright colors. Or use hangers to make wings and other accessories for costumes.

## Unclog toilets and vacuum cleaners

If your toilet is clogged by a foreign object, fish out the culprit with a straightened wire coat hanger. Use a straightened hanger to unclog a jammed vacuum cleaner hose.

## Make plant markers

Need some waterproof markers for your outdoor plants? Cut up little signs from a milk jug or similar rigid but easy-to-cut plastic. Write the name of the plant with an indelible marker. Cut short stakes from wire hangers. Make two small slits in each marker and pass the wire stakes through the slits. Neither rain nor sprinkler will obscure your signs.

## Hang a plant

Wrap a straightened wire coat hanger around a 6- to 8-in. flowerpot, just below the lip; twist it back on itself to secure it, then hang.

## Make a mini-greenhouse

To convert a window box into a mini-greenhouse, bend three or four lengths of coat hanger wire into U's and place the ends into the soil. Punch small holes in a dry-cleaning bag and wrap it around the box before putting it back in the window.

## Make a paint can holder

When you are up on a ladder painting your house, one hand is holding on while the other is painting. How do you hold the paint can? Grab a pair of wire snips and cut the hook plus 1 in. of wire from a wire hanger. Use a pair of pliers to twist the 1-in. section firmly around the handle of your paint can. Now you have a handy hanger.

## Cooking oil keeps drains stink-free

Under every drain in your house, there's a trap that holds water and prevents sewer gas from flowing up into the air you breathe. But if you have a shower that's been abandoned since the kids moved out or a floor drain that never gets used, the water in the trap can eventually evaporate. That lets in stinky—or even dangerous—sewer gases. The solution is a few ounces of cooking oil. Dump a bucket of water down the drain to refill the trap. Then add the oil. The floating oil forms a seal over the water and prevents future evaporation.



## Use a compact disc to peer into tight places



You can use a CD to look into tight places. Just peer through the little hole in the middle of the disc while you light the object by reflecting the light off the silvery surface. It works great for peering into corners and crevices (like inside appliances) where there's not enough room for your head or the flashlight.

## 11 uses for soap

### Loosen stuck zippers

Zipper stuck? Rub it loose with a bar of soap along the zipper's teeth. The soap's lubrication will get it moving.

### Unstick furniture drawers

If your cabinet or dresser drawers are sticking, rub the bottom of the drawer and the supports they rest on with a bar of soap.

### Lubricate screws and saw blades

A little lube with soap makes metal move through wood much more easily. Twist a screw into a bar of soap before driving it and rub some on your handsaw blade.

### Remove a broken lightbulb

If a bulb breaks while still screwed in, don't chance nicks and cuts trying to remove it. First, turn off the power. Insert the corner of a large, dry bar of soap into the socket. Give it a few turns and the base will unscrew.

### Say farewell to fleas

Fed up with those doggone fleas? Put a few drops of dish soap and some water on a plate. Place the plate on the floor next to a lamp. Fleas love light—they will jump on the plate and drown.

### Deodorize your car

Want your car to smell nice, but tired of those tree-shaped pine deodorizers? Place a little piece of your favorite-smelling soap in a mesh bag and hang it from your rearview mirror.

### Mark a hem

Forget store-bought marking chalk. A thin sliver of soap, like the ones left when a bar is just about finished, works just as well when you are marking a hem, and the markings wash right out.

### Make a pin holder

Here's an easy-to-make alternative to a pincushion. Wrap a bar of soap in fabric and tie the fabric in place with a ribbon. Stick in your pins. As a bonus, the soap lubricates the pins, making them easier to insert.

### Prevent cast-iron marks

Nip cookout cleanup blues in the bud. Rub the bottom of your cast-iron pot with a bar of soap before cooking over a sooty open flame.

### Keep stored clothes fresh

Pack a bar of your favorite scented soap when you store clothes or luggage. It will keep your clothes smelling fresh until next season and prevent musty odor in your luggage.

### Save those soap slivers

When your soap slivers get too tiny to handle, don't throw them away. Just make a small slit in a sponge and put the slivers inside. The soap will last for several more washings. Or make a washcloth that's easy for little hands to hold by putting the soap slivers in a sock.

### Make your own soap for gift-giving

Handcrafted soap makes a great gift and is easy to make. You need a solid bar of glycerin (from a drugstore); soap molds (from a crafts store); a clean, dry can; a double boiler; food coloring; and essential oil. Place the glycerin in the can and put the can in a double boiler, which has water in the top as well as the bottom, and heat until the glycerin melts. For color, mix in food coloring. Spray a mold with nonstick cooking spray and fill it halfway with melted glycerin. Add a few drops of essential oil and fill the rest with glycerin. Let it harden.

# 15 uses for toothpaste

## Remove scuffs from shoes

A little toothpaste does an amazing job of removing scuffs from leather shoes. Just squirt a dab on the scuffed area and rub with a soft cloth. Wipe clean with a damp cloth. The leather will look like new.

## Spiff up your sneakers

Want to clean and whiten the rubber part of your sneakers? Get out the non-gel toothpaste and an old toothbrush. After scrubbing, clean off the toothpaste with a damp cloth.

## Clean your clothes iron

The mild abrasive in non-gel toothpaste is just the ticket for scrubbing the gunk off the bottom plate of your clothes iron. Apply the toothpaste to the cool iron, scrub with a rag, then rinse clean.

## Polish a diamond ring

Put a little toothpaste on an old toothbrush and use it to make your diamond ring sparkle. Clean off the residue with a damp cloth.

## Deodorize baby bottles

Baby bottles inevitably pick up a sour-milk smell. Toothpaste will remove the odor in a jiffy. Just put some on your bottle brush and scrub away. Be sure to rinse thoroughly.



## Toothpaste cap light switch

Put a drop of silicone in the bottom of a clean toothpaste cap and push it over a standard knob to make it more grabbable. The lampshade conceals the larger knob, but if you don't like the look, you can darken the cap with a permanent marker to match the old knob.

## Remove beach tar

Getting that black beach tar on your feet can put a small crimp in your vacation, but it is easy enough to remove. Just rub it with some non-gel toothpaste and rinse.

## Prevent bathroom mirrors from fogging

Ouch! You cut yourself shaving and it's no wonder—you can't see your face clearly in that fogged-up bathroom mirror. Next time, coat the mirror with non-gel toothpaste and wipe it off before you get in the shower. When you get out, the mirror won't be fogged.

## Toothpaste clips

Use paper binder clips to keep the empty portion of toothpaste rolled up. The handles can be used to hang the tubes for neat, visible storage and flipped alongside the tube to help you squeeze.

## Clean the bathroom sink

Non-gel toothpaste works as well as anything else to clean the bathroom sink. The tube's sitting right there, so just squirt some in, scrub with a sponge, and rinse it out. Bonus: The toothpaste will kill any odors emanating from the drain trap.

## Remove crayon from walls

Grab a tube of non-gel toothpaste and a rag or—better yet—a scrub brush. Squirt the toothpaste on the wall and start scrubbing. The fine abrasive in the toothpaste will rub away the crayon every time. Rinse the wall with water.

## Remove ink or lipstick stains from fabric

This may or may not work, depending on the fabric and the ink, but it is certainly worth a try. Put non-gel toothpaste on the stain and rub the fabric vigorously together. Rinse with water. Did some of the ink come out? Great! Repeat the process a few more times until you get rid of all the ink. The same process works for lipstick.

## Clear up pimples

Dab a bit of non-gel, nonwhitening toothpaste on the offending spot, and it should be dried up by morning. The toothpaste dehydrates the pimple and absorbs the oil. This remedy works best on pimples that have come to a head. Caution: This remedy may be irritating to sensitive skin.

## Prevent fogged goggles

Whether you are doing woodworking or going skiing or scuba diving, nothing is more frustrating (and sometimes dangerous) than fogged goggles. Prevent the problem by coating the goggles with non-gel toothpaste and then wiping them off.

## Clean smells from hands

The ingredients in toothpaste that deodorize your mouth will work on your hands as well. If you've gotten into something stinky, wash your hands with toothpaste, and they'll smell great.



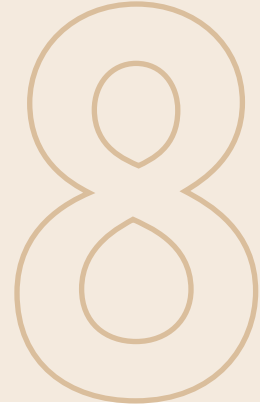

# Tool and workshop tips



The three dozen tips in this chapter show you how to quickly and efficiently arrange your workshop, protect and store your tools, loosen stuck fasteners and keep your work area clean and comfy. Most of these tips take 10 minutes or less to implement, and they'll make working in your shop a lot more enjoyable.



# 11 tips for loosening stubborn nuts, bolts & screws

## 1 Heat to the rescue



Heat, oil and tapping will unstick most nuts and bolts in metal. Apply only enough heat to cause expansion in the entire bolt—about a minute or so for the average-size bolt. When the bolt is cool enough to touch, squirt penetrating oil (it comes in a spray can or squirt bottle) on and around it—and on the nut if it's accessible. Be careful, that stuff is flammable. Tap the end of the bolt a half-dozen times with a hammer to help loosen the threads and allow the oil to penetrate. Wait another minute or so for the oil to work, and then use your wrench.

## 2 Adjustable wrench technique

An adjustable wrench isn't the ideal tool for loosening stuck fasteners because it can round over the head, making matters worse. But if an adjustable wrench is your only option, here's your best shot at preserving the shoulders on the nut or bolt head: Slide on the wrench all the way, so there's full contact at the back of the jaws. Then tighten the wrench thumbscrew so there's no play at all in the jaws. Always turn the wrench handle toward the lower jaw, never away from it.

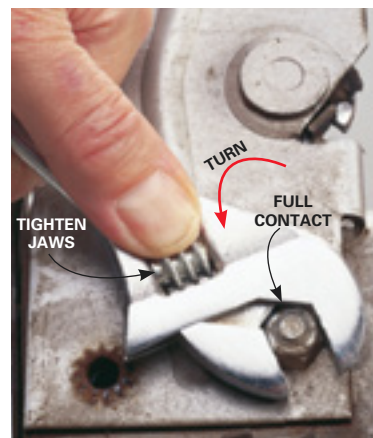

## 3 Impact driver

An impact driver works with a bladed or Phillips-head screwdriver bit, or a socket head. Striking the tool does three things at once: The blow loosens the thread bond; the downward force keeps the tool in the slot; and the head of the tool turns 20 degrees in the loosening direction. Make sure the screw slot is clean and free of debris.



## 4 Use a cheater bar (and the right socket)

Be a cheater by slipping a short length of pipe—a cheater bar—over the end of your tool handle. The extra length gives you much better leverage. Be careful, though, not to use so much force that

you break the tool or break the head off the shank of the bolt.

You'll find that six-point sockets get a better grip on hex nuts and bolts than 12-point sockets, which are designed to fit both hex and square fasteners.



**Caution:**  
The cheater bar technique can exceed the design strength of the tool, cause it to break and void the tool warranty. Wear eye protection.





## 5 Mangled slot (solution 1)

If the slot of a roundhead screw or bolt is chewed up beyond hope of gripping it with a screwdriver, file two flat edges on it. Then turn the head with an adjustable wrench.



## 6 Mangled slot (solution 2)

Use a hacksaw to cut a new slot at a right angle to the old one. For big screws, put two blades in your hacksaw, right next to each other, and cut a wider slot so you can use a big screwdriver. This is also a great way to get a grip on the head of a stuck carriage bolt, which has no slot or flats.

## 7 Split a nut

A nut splitter, also called a nut cracker, will crack any no-turn nut without damaging the threads of the bolt or stem that it's screwed onto. Just slip the ring over the nut and turn the tooth into the nut until it breaks. Find a nut cracker at Sears, Amazon and tool stores.



## 8 A screw extractor

A screw extractor could save your day. It will grab just about any threaded fastener and remove it—even if the head has snapped off. It usually comes with a hardened drill bit to drill a hole in the center of your stubborn screw or bolt. Then you turn the extractor counterclockwise into the hole. Because of its tapered shape and lefthand thread, the extractor will jam in the hole and then begin to turn out the screw.



## 9 Off with its head

When there's no other solution—when heat, penetrating oil and wrenches have all failed—cut off bolt heads or nuts with a hacksaw, reciprocating saw or a cold chisel. Some smaller fasteners, especially rivets and flathead bolts, may be easier to drill out than to cut.



## 10 Get a grip

When a bolt head has become so rounded that a wrench won't get a bite, use locking pliers. Get a tight grip: You may have only two or three chances before the head gets so rounded that even this won't work. Use penetrating oil, heat and tapping if it slips after your first try.



## 11 Sticking screw

Try a wrench on a screwdriver blade for that big screw that won't budge. Select the largest screwdriver that'll fit, and tap the butt of the handle with a hammer. Lean your weight onto the screwdriver to keep it in the slot as you turn it with the wrench. Careful—too much torque will bend the screwdriver tip.

## "On the level" table saw

You've finally got your table saw on a mobile base so it's easy to pull out and put away on the weekend. Finish the job by finding a level spot on the floor that's also convenient for sawing boards without obstruction. Mark the wheel positions with bright-colored duct tape and now you can roll the saw to the same flat spot every time you saw.



## Forward-facing hacksaw teeth

Install the blade on a hacksaw so the teeth face forward. The saws are designed so the blade will cut when it's pushed (the forward stroke) rather than when pulled. Some blades have an arrow that shows the correct installation (the arrow points toward the handle). Install the blade so it's tight in the saw and won't bend. When you do a lot of cutting, the blade will heat up and expand, so be sure to tighten it if it starts to bend.

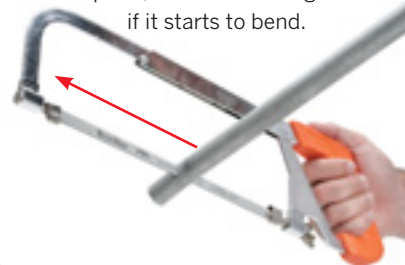

## Carpet pad for soft footing



A double layer of foam carpet pad makes a luxurious but inexpensive anti-fatigue mat beside workbenches and power tools. Cut the pad to size with a utility knife, scissors or tin snips. To avoid tripping and to keep the edges from curling, tape down the perimeter with packing or duct tape.

## No-slip tools

When you're working on the roof, wrap rubber bands around tools to help them stay put. The rubber will grip on roofs with up to a 6/12 slope.

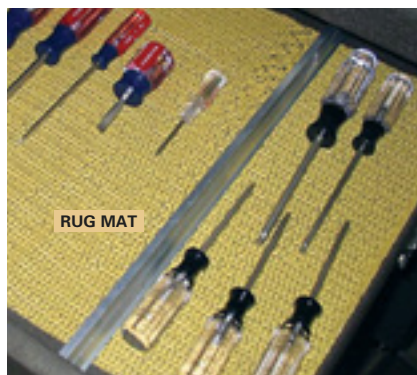

## Toolbox liner

Rubbery shelf liner works great in toolboxes, but there's a cheaper alternative. Cut a nonslip rug mat to fit any size drawer and keep tools from sliding around.

## Laser plumb bob

Turn your key-chain laser pointer into a plumb bob. Replace the key chain with mason's line or other light string and hold the button down with a zip tie. Hang the laser as you would a plumb bob and mark right on the laser dot.



The New Crescent  
Pass-Thru™ Adjustable Wrench Set

Get Three Tools In One

- A Precision Adjustable Wrench  
*The ultimate multi-purpose tool*
- A Tight-gripping Pipe Wrench  
*Reverse the jaw for extreme turning power*
- A Pass-Thru™ Ratchet with 10 Sockets  
*Fits Hex, Square, 12-Point, E-Torx®, Partially Rounded Hex, and Spline ...  
in both SAE and metric sizes*

[www.CrescentTool.com](http://www.CrescentTool.com)

SAE  
+  
MM



More Innovation from Crescent Tools.

See videos for both these products at [www.CrescentTool.com/video-gallery](http://www.CrescentTool.com/video-gallery)

Available at

Crescent® Quick-Convert Nutdrivers.  
Speed when you want it.  
Torque when you need it.



Switch from standard to T-handle...  
just pull the shaft, rotate the  
handle, and push to lock.

[www.CrescentTool.com](http://www.CrescentTool.com)

## Onboard glue spreader

To make spreading glue less messy, all you need is an old credit card, a 3/4-in. two-hole EMT conduit strap and two 1/8-in. nuts and bolts.

Crook the conduit strap in a vise to level the conduit strap wings with the bottle cap. This way the credit card stays flat when you bolt it on. Drill a couple of window holes in the middle of the credit card so you can monitor the size of the glue bead, then drill bolt holes in the end of the card, snap the conduit strap onto the bottle cap and bolt on the card.

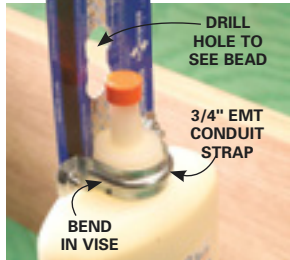

Practice applying glue on a scrap board and in a few minutes you'll get it down. Be sure to use fresh glue—the lightly bending card will spread it like butter.



## Racquet caddy

Here's a slick use for that old wooden tennis racquet that's gathering dust in the garage. Drill a hole in the handle and screw it to the underside of a workbench. Position the racquet so it can swing in and out from under the table. Use it to hold tools, parts or other small items.



## Rosin paper workbench cover

Here's instant protection for any kind of messy job. Before you start, just unroll enough rosin paper from this jumbo paper towel holder to protect your workbench. The thick paper absorbs all the glue or finish. When the paper gets too dirty, tear it off and throw it away. A roll of rosin paper is 170 ft. long, so one will last a long time. Here's how to build your paper holder:

Buy a roll of rosin paper and a length of 1-1/2-in. pipe at a home center. Round up some scrap lumber and get ready to do a little bit of head scratching to customize a bracket arrangement that works with your bench design. Bore 1-7/8-in. holes in the scrap wood brackets. Screw keeper strips over the holes to keep the pipe from falling out as you unroll the paper. Use a handsaw to cut the paper roll and a hacksaw to cut the pipe to match the width of your bench. Then load the roll and start dripping stuff all over it.

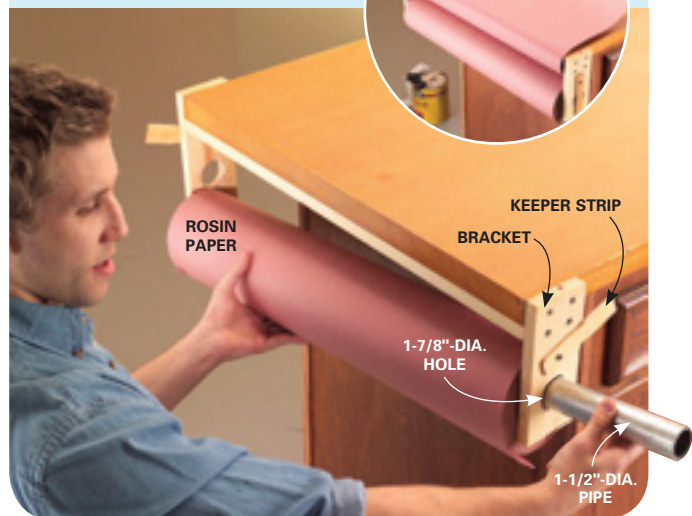
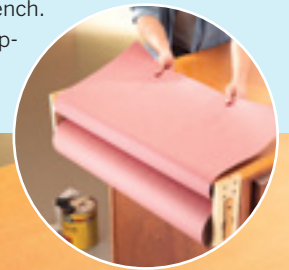



## Farewell, planer snipe

In a wood shop, a “snipe” isn’t an imaginary bird. It’s a long, shallow trough that gets carved into boards an inch or two from the trailing end just before a board exits a thickness planer. The smart way to deal with snipe is to plane boards before cutting them to length, then just cut off any snipes. But sometimes there’s not enough length to do that, especially when you buy small, expensive chunks of exotic wood. Here’s what to do then: Trace the last 4 in. of your “beauty board” on a wider scrap board of the same thickness. Saw out the notch, fit the two boards together and plane them as one. Any snipe or gouging will show up on the trailing board, not on your workpiece.

## Pointy-tool pincushion

Store router bits, drill bits, screwdrivers, awls, pencils, Allen wrenches and hole saws in a chunk of 1-1/2-in.-thick rigid foam insulation.

To make this pointy-tool pincushion, just glue the foam to 1/2-in. plywood sized an inch wider than the foam. Be sure to use foam-compatible adhesive (PL 500 is one). Then press the foam into place and let it dry for a few hours. Punch holes for the accessories by rotating a small-diameter Phillips screwdriver or an awl at a slight angle into the foam. The tools will widen the holes to fit as you push them in. Screw the plywood to a shop wall over your workbench and load it up!

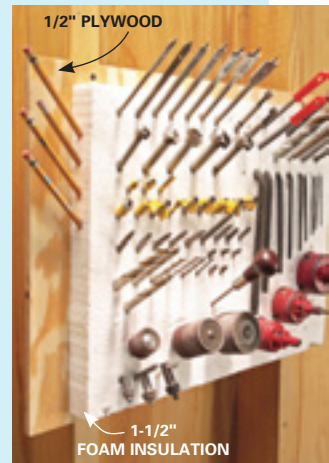

## No-mar horses

It’s a good idea to have a set of sawhorses with carpeted tops for sanding or working with fine pieces of finished wood. Just trim carpeting scraps to size and hot-glue them to the wood tops of your horses. Now you can sand without getting scuff marks on the bottom of the workpiece and assemble prefinished work without leaving marks or scratches.



## Ambient air cleaning on the cheap

Can’t afford an air cleaner for those dusty woodworking jobs on the weekend? Think again. Attach a furnace filter with hook-and-loop tabs to the air intake side of a box fan and hang the fan between the ceiling joists so you won’t hit your head on it while you work. Just switch it on and fine dust particles from sanding and sawing will be drawn into the filter by the vacuum created by the fan.



## Quick blade cover-up

Recycle old garden hose by slitting open a length and using it as a blade cover for sharp saws and other bladed tools.





## 10-ft. level for \$15

When you need to extend the reach of your level, use steel studs. They're straighter, lighter and cheaper than wood. For stiffness, nest two together and tape them. Then tape on a torpedo level (or use a magnetic one) and you've got a long-reach level.



## In-the-bag shop vac filter cleaning

Here's how to clean your shop vacuum filter without filling the backyard (and your lungs) with a month's worth of shop dust. Stick it in a plastic garbage bag, knot or grip the bag's open end, then gently hit the filter to dislodge the dust. Set the bag down, wait for the dust to settle, then remove the filter and dispose of the bag.



## Corner-on pegboard hooks

Ever had a plane, level or square get dinged up after falling off the pegboard? Never again. Bend an 8-in.-long pegboard holder into a corner shape by holding it in a vise and pounding it with a hammer to make the series of right angles. Make one corner to hold the left side of the tool and another to hold the right. Now just hold the tool up to the pegboard and insert the corner peg so it clasps the tool's corner.

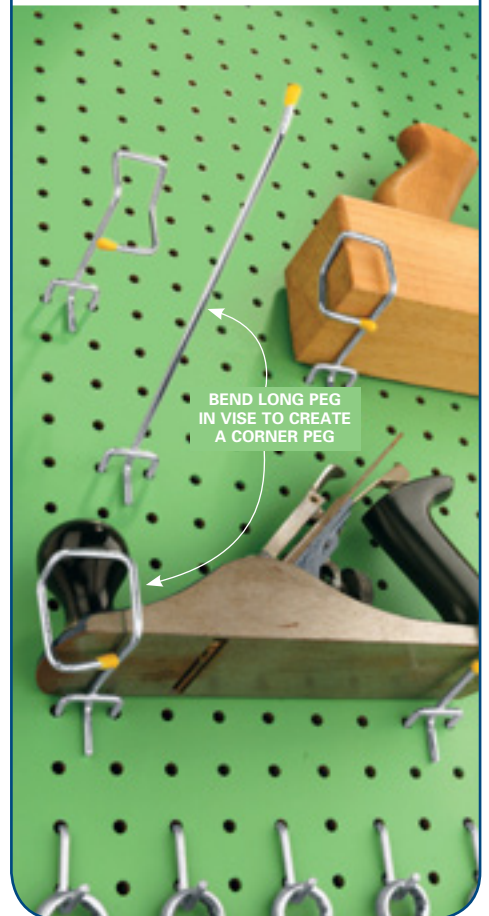

## A wrench rack from the clothes closet

Are all your wrenches stuffed in a plastic bucket? Here's a better idea. Screw a tie/belt rack (available at discount stores) to a bare spot on the wall over your workbench and hang the wrenches—SAE and metric—where you can swiftly nab and put them away in an orderly fashion.

## String-dispensing CD bins

Here's a great way to reuse empty CD bins. Drill a hole in the top of the bin for the string to slide through, then screw the lid under a shelf and snap on the string-loaded bin. Pull down and snip off the desired length and never worry that your ball of string will roll away across the floor.

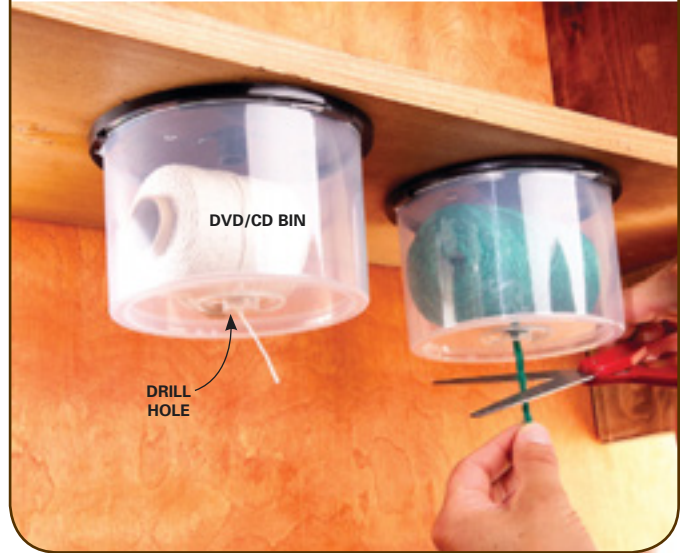

## Top-shelf safety glasses

Toss your safety glasses into the top rack of your dishwasher after a messy project. Smudges, sunscreen and sweat will disappear with no effort.



## Adjustable drawer partitions

You can restore order in messy shop drawers with 1/4-in. plywood partitions and Self-Adhesive Foam Tape Weather Strip. These drawer dividers will organize your tools, tape and twine, and you can easily inch them sideways to accommodate larger items. For the strongest grip, use spongy “closed cell” weather stripping.

Apply weather stripping to the sides of the drawers as shown, then

cut the partitions long enough so they squish firmly into the rubber on both ends. A good rule of thumb is to make the partitions 1/4 in. longer than the inside measurement between the pieces of weather stripping.

To install a partition, hold it at an angle to the front and back sides, then rotate it into position.





## Magnetic broom

When you spill screws, nails, brads or other small metal parts on a dusty shop floor, pick them up in seconds, minus the dust. Screw a 3-in.-dia. pot magnet on the end of a wood dowel to create your “picker-upper.” To use this tool, place an inside-out sandwich bag over the magnet and start sweeping the area. The hardware will leap up to the powerful magnet as you “sweep” the floor. To unload and bag the metal pieces in one quick step, just pull the bag off the magnet.



## PVC toolholder

Build this PVC rack to store your tools on the wall. Use a jigsaw to cut a 1-1/4-in.-wide notch down the length of a 2-in.-dia. PVC pipe. Cut several 3-1/2-in.-long sections with a hacksaw or miter saw, and drill two 1/8-in. holes behind the notch. Use 1-1/4-in. drywall screws to attach these pieces to a 2x4 screwed to the wall.



## Safety glasses insurance

Protect safety glasses by storing them in an old sock. Hang the sock on the wall in your workshop, and they'll remain scratch-free, dust-free and easy to find.



## Handsaw blade saver

Prolong the life of your saw blades with a short section of 1/2-in. PVC pipe. Hold the pipe tight against slightly opened vise jaws, and saw a slit down the entire pipe (this is a tricky cut, but it only has to be done once). Slide it over the blade to keep the teeth sharp.

